

10EC73 POWER ELECTRONICS

Subject Code	:	10EC73	IA Marks	:	25
No. of Lecture Hrs./ Week	:	04	Exam Hours	:	03
Total No. of Lecture Hrs.	:	52	Exam Marks	:	100

PART – A**UNIT 1:****Power Semiconductor Devices:**

Introduction to semiconductors, Power Electronics, Power semiconductor devices, Control Characteristics. Types of power electronic converters and industrial applications-Drives, Electrolysis, Heating, Welding, Static Compensators, SMPS, HVDC power transmission, Thyristorized tapped changers and Circuit breakers.

7 hours**UNIT 2:**

Power Transistors: Power BJT's – switching characteristics, switching limits, base drive control. Power MOSFET's and IGBT's –characteristics, gate drive, di/dt and dv/dt limitations. Isolation of gate and base drives. Simple design of gate and base drives.

6 Hours**UNIT 3:****Thyristors**

Introduction, Two Transistor Model, characteristics-static and dynamic. di/dt and dv/dt protection. Thyristor types. Series and parallel operation of Thyristors. Thyristor firing circuits. Simple design of firing circuits using UJT, op-amps, and digital IC's.

7 Hours**UNIT 4:**

Commutation Techniques: Introduction. Natural Commutation. Forced commutation- self-commutation, impulse commutation, resonant pulse commutation and complementary commutation.

6 Hours

PART – B**UNIT 5:**

Controlled Rectifiers: Introduction. Principle of phase controlled converter operation. Single- phase semi-converters. Full converters. Three-phase half-wave converters. Three-phase full-wave converters. **7 Hours**

UNIT 6:

Choppers: Introduction. Principle of step-down and step-up chopper with R-L load. Performance parameters. Chopper classification. Analysis of impulse commutated thyristor chopper (only qualitative analysis) **6 Hours**

UNIT 7:

Inverters: Introduction. Principle of operation. Performance parameters. Single-phase bridge inverters. Three-phase inverters. Voltage control of single-phase inverters – single pulse width, multiple pulse width, and sinusoidal pulse width modulation. Current source inverters. Variable D.C. link inverter. **7 Hours**

1

UNIT 8:

(a) AC Voltage Controllers: Introduction. Principle of ON-OFF and phase control. Single-phase, bi-directional controllers with resistive and inductive loads.

(b) Electromagnetic Compatibility: Introduction, effect of power electronic converters and remedial measures. **6 Hours**

Text Book:

1. **Power Electronics**, M.H.Rashid, , Pearson, 3rd Edition, 2006.
2. **Power Electronics**, M.D. Singh and Khanchandani K.B., T.M.H., 2nd Edition, 2001

References

1. **Power Electronics Essentials and Applications**, L. Umanand, Wiley India Pvt Ltd, Reprint, 2010
2. **Thyristorised Power Controllers**, G.K. Dubey, S.R. Doradla, A. Joshi and R.M.K. Sinha, New Age International Publishers.
3. **Power Electronics – Converters, Applications and Design**, Ned Mohan, Tore M. Undeland, and William P. Robins, Third Edition, John Wiley and Sons, 2008.
4. **Power Electronics: A Simplified Approach**, R.S. Ananda Murthy and V. Nattarasu, Pearson/Sanguine Technical Publishers.

INDEX SHEET

UNIT	TOPIC	PAGE NO.
UNIT – 1: INTRODUCTION		01
1.1	Brief History of Power Electronics	01
1.2	Power Electronic Application	01
1.3	Power Semiconductor Devices	02
1.4	Control Characteristics Of Power Devices	06
1.5	Types of Power Converters or Types of Power Electronic Circuits	08
1.6	Peripheral Effects	13
UNIT-2: POWER TRANSISTOR		19
2.1	Bipolar Junction Transistors	19
2.2	Transistor as a Switch	23
2.3	Transient Model of BJT	28
2.4	Switching Limits	32
2.5	Power MOSFET'S	39
2.6	Switching Characteristics	44
2.7	IGBT	47
2.8	di/dt and dv/dt Limitations	50
2.9	Isolation of Gate and Base Drives	52
UNIT -3: INTRODUCTION TO THYSISTORS		56
3.1	Silicon Controlled Rectifier (SCR)	56
3.2	Thyristor Gate Characteristics	60
3.3	Quantitative Analysis	61
3.4	Switching Characteristics (Dynamic characteristics)	63
3.5	Resistance Triggering	69
3.6	Resistance Capacitance Triggering	71
3.7	Uni-Junction Transistor (UJT)	73
3.8	UJT Relaxation Oscillator	75
3.9	Synchronized UJT Oscillator	80
3.10	$\frac{dv}{dt}$ Protection	84
3.11	$\frac{di}{dt}$ Protection	87

UNIT-4 CONTROLLED RECTIFIERS		89
4.1	Line Commutated AC to DC converters	89
4.2	Applications of Phase Controlled Rectifiers	89
4.3	Classification of Phase Controlled Rectifiers	90
4.4	Principle of Phase Controlled Rectifier Operation	90
4.5	Control Characteristic of Single Phase Half Wave Phase Controlled Rectifier with Resistive Load	92
4.6	Single Phase Full Wave Controlled Rectifier Using A Center Tapped Transformer	102
4.7	Single Phase Full Wave Bridge Controlled Rectifier	109
4.8	Single Phase Dual Converter	120
UNIT-5 COMMUTATION		126
5.1	Introduction	126
5.2	Self Commutation or Load Commutation	128
5.3	Resonant Pulse Commutation	140
5.4	Complementary Commutation	154
5.5	Impulse Commutation	158
5.6	External Pulse Commutation	165
UNIT-6 AC VOLTAGE CONTROLLER		168
6.1	Phase Control	168
6.2	Type of Ac Voltage Controllers	169
6.3	Principle of On-Off Control Technique (Integral Cycle Control	170
6.4	Principle Of Ac Phase Control	178
6.5	Single Phase Full Wave Ac Voltage Controller (Ac Regulator) or Rms Voltage Controller with Resistive Load	188
6.6	Single Phase Full Wave Ac Voltage Controller (Bidirectional Controller) With RL Load	194
UNIT-7 DC CHOPPER		216
7.1	Introduction	216
7.2	Principle of Step-down Chopper	216
7.3	Principle of Step-up Chopper	224
7.4	Classification of Choppers	230
7.5	Impulse Commutated Chopper	236
UNIT-8 INVERTERS		242
8.1	Classification of Inverters	242
8.2	Principle of Operation	242
8.3	Half bridge inverter with Inductive load	243
8.4	Fourier analysis of the Load Voltage Waveform of a Half Bridge Inverter	245
8.5	Performance parameters of inverters	248
8.6	Single Phase Bridge Inverter	250
8.7	Single Phase Bridge Inverter with RL Load	252
8.8	Comparison of half bridge and full bridge inverters	258
8.9	Principle of Operation of CSI:	258
8.10	Variable DC link Inverter	261

UNIT-1

INTRODUCTION TO POWER ELECTRONICS

Power Electronics is a field which combines Power (electric power), Electronics and Control systems.

Power engineering deals with the static and rotating power equipment for the generation, transmission and distribution of electric power.

Electronics deals with the study of solid state semiconductor power devices and circuits for Power conversion to meet the desired control objectives (to control the output voltage and output power).

Power electronics may be defined as the subject of applications of solid state power semiconductor devices (Thyristors) for the control and conversion of electric power.

1.1 Brief History of Power Electronics

The first Power Electronic Device developed was the Mercury Arc Rectifier during the year 1900. Then the other Power devices like metal tank rectifier, grid controlled vacuum tube rectifier, ignitron, phanotron, thyatron and magnetic amplifier, were developed & used gradually for power control applications until 1950.

The first SCR (silicon controlled rectifier) or Thyristor was invented and developed by Bell Lab's in 1956 which was the first PNPN triggering transistor.

The second electronic revolution began in the year 1958 with the development of the commercial grade Thyristor by the General Electric Company (GE). Thus the new era of power electronics was born. After that many different types of power semiconductor devices & power conversion techniques have been introduced. The power electronics revolution is giving us the ability to convert, shape and control large amounts of power.

1.2 Power Electronic Applications

1. COMMERCIAL APPLICATIONS

Heating Systems Ventilating, Air Conditioners, Central Refrigeration, Lighting, Computers and Office equipments, Uninterruptible Power Supplies (UPS), Elevators, and Emergency Lamps.

2. DOMESTIC APPLICATIONS

Cooking Equipments, Lighting, Heating, Air Conditioners, Refrigerators & Freezers, Personal Computers, Entertainment Equipments, UPS.

3. INDUSTRIAL APPLICATIONS

Pumps, compressors, blowers and fans. Machine tools, arc furnaces, induction furnaces, lighting control circuits, industrial lasers, induction heating, welding equipments.

4. AEROSPACE APPLICATIONS

Space shuttle power supply systems, satellite power systems, aircraft power systems.

5. TELECOMMUNICATIONS

Battery chargers, power supplies (DC and UPS), mobile cell phone battery chargers.

6. TRANSPORTATION

Traction control of electric vehicles, battery chargers for electric vehicles, electric locomotives, street cars, trolley buses, automobile electronics including engine controls.

1.3 POWER SEMICONDUCTOR DEVICES

The power semiconductor devices are used as on/off switches in power control circuit. These devices are classified as follows.

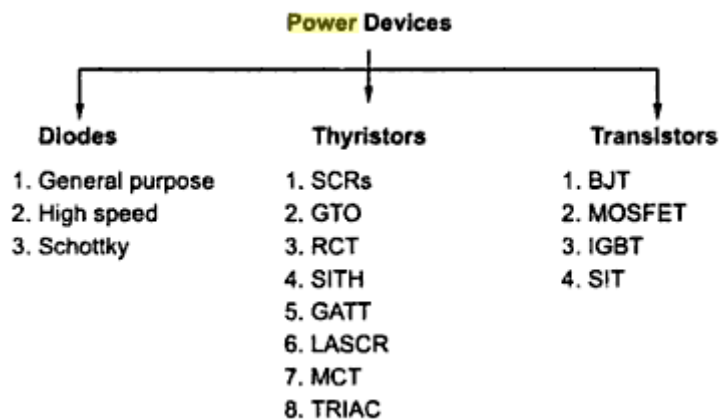

A. POWER DIODES

Power diodes are made of silicon p-n junction with two terminals, anode and cathode. Diode is forward biased when anode is made positive with respect to the cathode. Diode conducts fully when the diode voltage is more than the cut-in voltage (0.7 V for Si). Conducting diode will have a small voltage drop across it.

Diode is reverse biased when cathode is made positive with respect to anode. When reverse biased, a small reverse current known as leakage current flows. This leakage current increases with increase in magnitude of reverse voltage until avalanche voltage is reached (breakdown voltage).

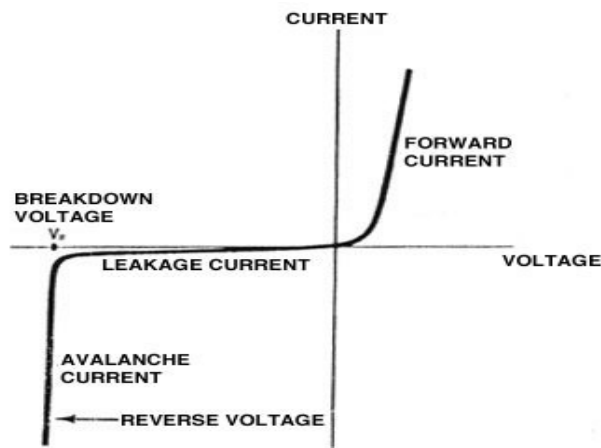

Fig.1.1 V-I Characteristics of diode.

POWER DIODES TYPES

Power diodes can be classified as

- General purpose diodes.
- High speed (fast recovery) diodes.
- Schottky diode.

General Purpose Diodes

The diodes have high reverse recovery time of about 25 microseconds (μsec). They are used in low speed (frequency) applications. e.g., line commutated converters, diode rectifiers and converters for a low input frequency upto 1 KHz. Diode ratings cover a very wide range with current ratings less than 1 A to several thousand amps (2000 A) and with voltage ratings from 50 V to 5 KV. These diodes are generally manufactured by diffusion process. Alloyed type rectifier diodes are used in welding power supplies. They are most cost effective and rugged and their ratings can go upto 300A and 1KV.

Fast Recovery Diodes

The diodes have low recovery time, generally less than 5 μs . The major field of applications is in electrical power conversion i.e., in free-wheeling ac-dc and dc-ac converter circuits. Their current ratings is from less than 1 A to hundreds of amperes with voltage ratings from 50 V to about 3 KV. Use of fast recovery diodes are preferable for free-wheeling in SCR circuits because of low recovery loss, lower junction temperature and reduced di/dt . For high voltage ratings greater than 400 V they are manufactured by diffusion process and the recovery time is controlled by platinum or gold diffusion. For less than 400 V rating epitaxial diodes provide faster switching speeds than diffused diodes. Epitaxial diodes have a very narrow base width resulting in a fast recovery time of about 50 ns.

Schottky Diodes

A Schottky diode has metal (aluminium) and semi-conductor junction. A layer of metal is deposited on a thin epitaxial layer of the n-type silicon. In Schottky diode there is a larger barrier for electron flow from metal to semi-conductor. Figure shows the schotty diode.

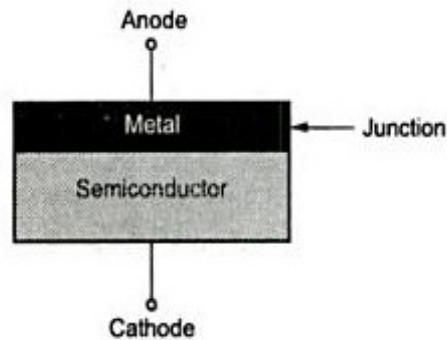

When Schottky diode is forward biased free electrons on n-side gain enough energy to flow into the metal causing forward current. Since the metal does not have any holes there is no charge storage, decreasing the recovery time. Therefore a Schottky diode can switch-off faster than an ordinary p-n junction diode. A Schottky diode has a relatively low forward voltage drop and reverse recovery losses. The leakage current is higher than a p-n junction diode. The maximum allowable voltage is about 100 V. Current ratings vary from about 1 to 300 A. They are mostly used in low voltage and high current dc power supplies. The operating frequency may be as high 100-300 kHz as the device is suitable for high frequency application.

Comparison Between Different Types Of Diodes

General Purpose Diodes	Fast Recovery Diodes	Schottky Diodes
Upto 5000V & 3500A	Upto 3000V and 1000A	Upto 100V and 300A
Reverse recovery time – High	Reverse recovery time – Low	Reverse recovery time – Extremely low.
$t_{rr} \approx 25\mu s$	$t_{rr} = 0.1\mu s$ to $5\mu s$	$t_{rr} =$ a few nanoseconds
Turn off time - High	Turn off time - Low	Turn off time – Extremely low
Switching frequency – Low	Switching frequency – High	Switching frequency – Very high.
$V_F = 0.7V$ to $1.2V$	$V_F = 0.8V$ to $1.5V$	$V_F \approx 0.4V$ to $0.6V$

B. Thyristors

Silicon Controlled Rectifiers (SCR):

The SCR has 3- terminals namely:

Anode (A), Cathode (k) and Gate(G).

Internally it is having 4-layers p-n-p-n as shown in figure (b).

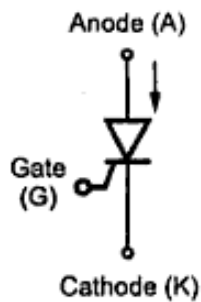

Fig.1.2 (a). Symbol

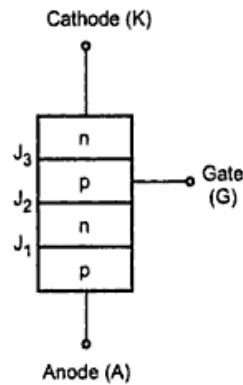

Fig.1.2 (b). Structure of SCR

The word thyristor is coined from thyatron and transistor. It was invented in the year 1957 at Bell Labs.

The Thyristors can be subdivided into different types

- Forced-commutated Thyristors (Inverter grade Thyristors)
- Line-commutated Thyristors (converter-grade Thyristors)
- Gate-turn off Thyristors (GTO).
- Reverse conducting Thyristors (RCT's).
- Static Induction Thyristors (SITH).
- Gate assisted turn-off Thyristors (GATT).
- Light activated silicon controlled rectifier (LASCR) or Photo SCR's.
- MOS-Controlled Thyristors (MCT's).

C. POWER TRANSISTORS

Transistors which have high voltage and high current rating are called power transistors. Power transistors used as switching elements, are operated in saturation region resulting in a low - on state voltage drop. Switching speed of transistors is much higher than the thyristors. And they are extensively used in dc-dc and dc-ac converters with inverse parallel connected diodes to provide bi-directional current flow. However, voltage and current ratings of power transistor are much lower than the thyristors. Transistors are used in low to medium power applications. Transistors are current controlled device and to keep it in the conducting state, a continuous base current is required.

Power transistors are classified as follows

- Bi-Polar Junction Transistors (BJTs)
- Metal-Oxide Semi-Conductor Field Effect Transistors (MOSFETs)
- Insulated Gate Bi-Polar Transistors (IGBTs)

- Static Induction Transistors (SITs)

1.4 CONTROL CHARACTERISTICS OF POWER DEVICES

The power semiconductor devices are used as switches. Depending on power requirements, ratings, fastness & control circuits for different devices can be selected. The required output is obtained by varying conduction time of these switching devices.

Control characteristics of Thyristors:

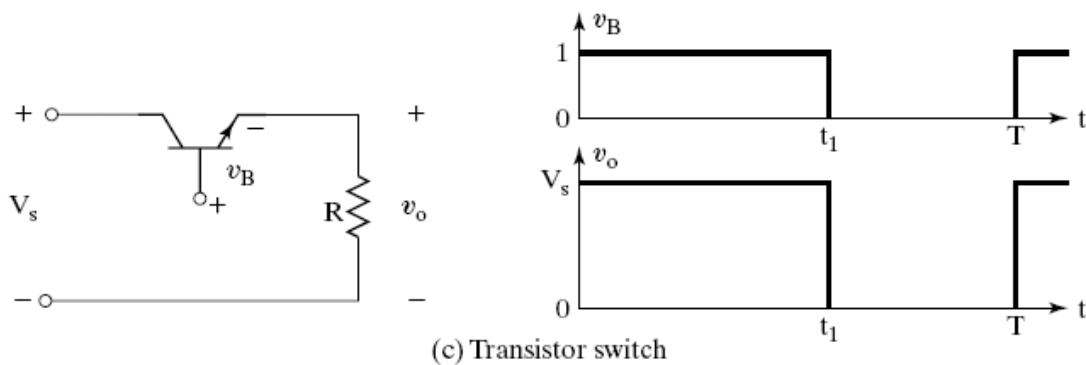
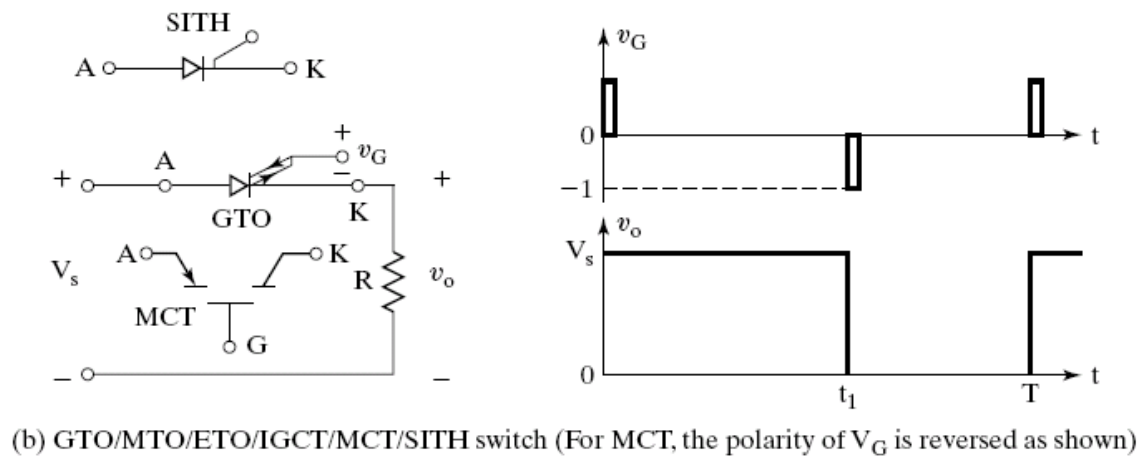
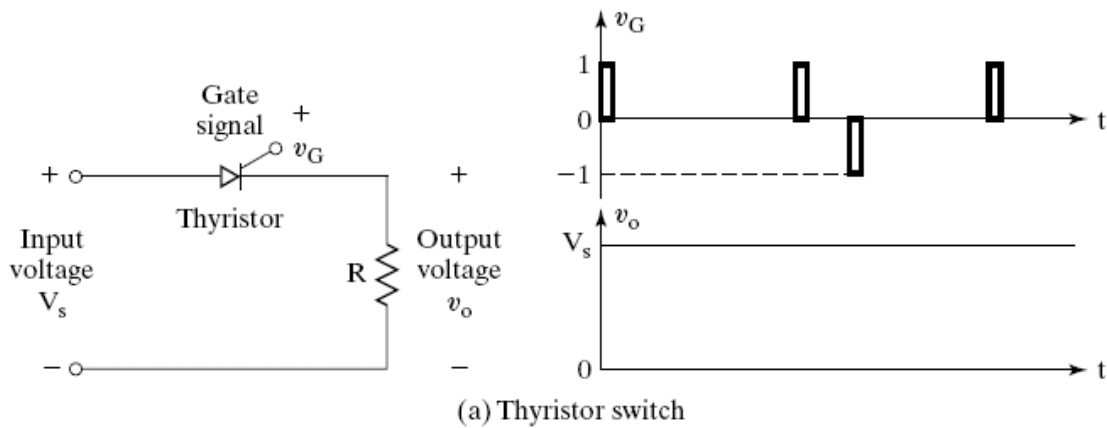

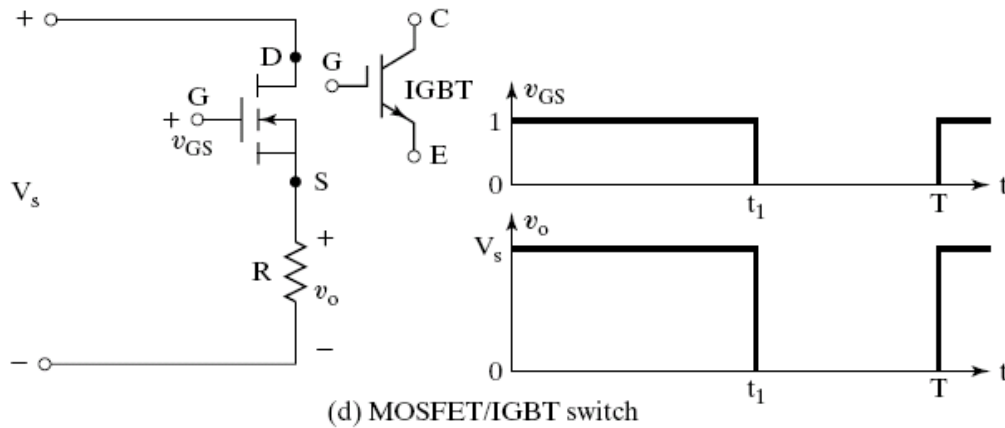

Fig1.3: Control Characteristics of Power Switching Devices

Classification of power semiconductor devices:

- Uncontrolled turn on and turn off (e.g.: diode).
- Controlled turn on and uncontrolled turn off (e.g. SCR)
- Controlled turn on and off characteristics (e.g. BJT, MOSFET, GTO, SITH, IGBT, SIT, MCT).
- Continuous gate signal requirement (e.g. BJT, MOSFET, IGBT, SIT).
- Pulse gate requirement (e.g. SCR, GTO, MCT).
- Bipolar voltage withstanding capability (e.g. SCR, GTO).
- Unipolar voltage withstanding capability (e.g. BJT, MOSFET, GTO, IGBT, MCT).
- Bidirectional current capability (e.g.: Triac, RCT).
- Unidirectional current capability (e.g. SCR, GTO, BJT, MOSFET, MCT, IGBT, SITH, SIT & Diode).

1.5 Types of Power Converters or Types of Power Electronic Circuits

For the control of electric power supplied to the load or the equipment/machinery or for power conditioning the conversion of electric power from one form to other is necessary and the switching characteristic of power semiconductor devices (Thyristors) facilitate these conversions.

The thyristorised power converters are referred to as the static power converters and they perform the function of power conversion by converting the available input power supply in to output power of desired form.

The different types of thyristor power converters are

- Diode rectifiers (uncontrolled rectifiers).
- Line commutated converters or AC to DC converters (controlled rectifiers)
- AC voltage (RMS voltage) controllers (AC to AC converters).
- Cyclo converters (AC to AC converters at low output frequency).
- DC choppers (DC to DC converters).
- Inverters (DC to AC converters).

1. AC TO DC Converters (Rectifiers)

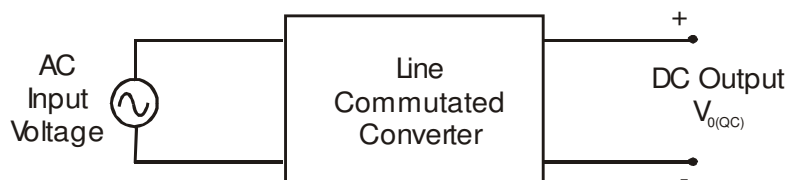

These are AC to DC converters. The line commutated converters are AC to DC power converters. These are also referred to as controlled rectifiers. The line commutated converters (controlled rectifiers) are used to convert a fixed voltage, fixed frequency AC power supply to obtain a variable DC output voltage. They use natural or AC line commutation of the Thyristors.

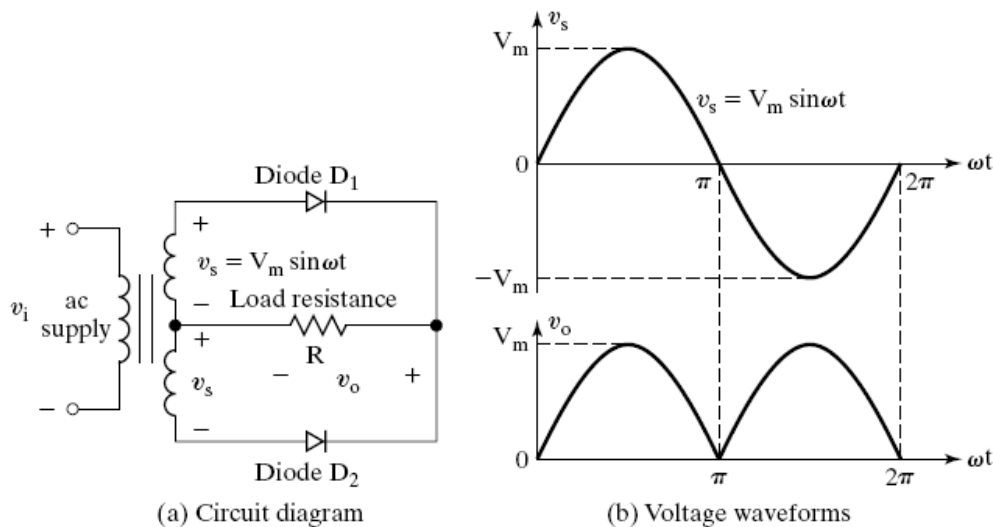

Fig1.4: A Single Phase Full Wave Uncontrolled Rectifier Circuit (Diode Full Wave Rectifier) using a Center Tapped Transformer

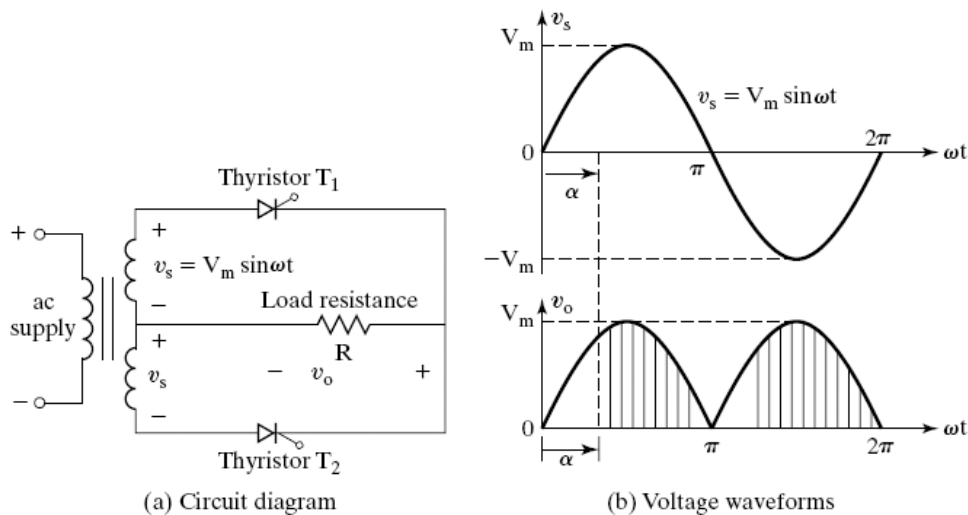

Fig: 1.5 A Single Phase Full Wave Controlled Rectifier Circuit (using SCRs) using a Center Tapped Transformer

Different types of line commutated AC to DC converters circuits are

- Diode rectifiers – Uncontrolled Rectifiers
- Controlled rectifiers using SCR's.
 - Single phase controlled rectifier.
 - Three phase controlled rectifiers.

Applications of Ac To Dc Converters

AC to DC power converters are widely used in

- Speed control of DC motor in DC drives.

- UPS.
- HVDC transmission.
- Battery Chargers.

2. a. AC TO AC Converters or AC regulators.

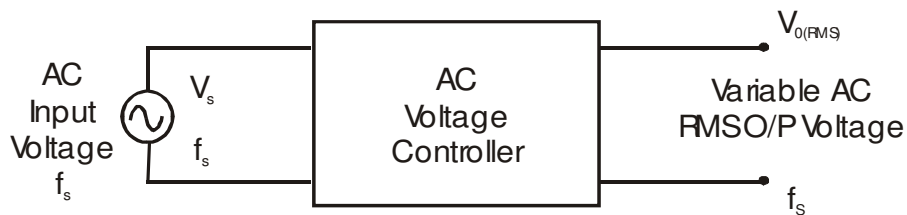

The AC voltage controllers convert the constant frequency, fixed voltage AC supply into variable AC voltage at the same frequency using line commutation.

AC regulators (RMS voltage controllers) are mainly used for

- Speed control of AC motor.
- Speed control of fans (domestic and industrial fans).
- AC pumps.

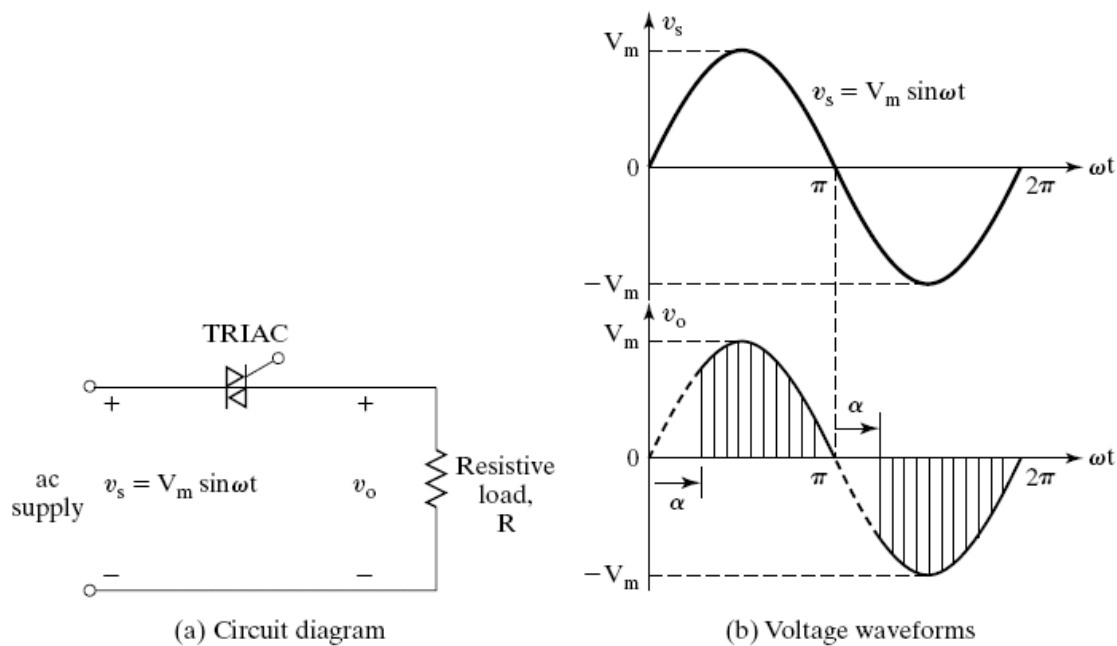
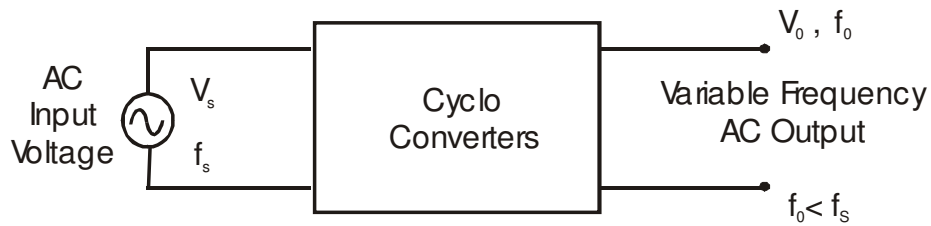

Fig.1.6: A Single Phase AC voltage Controller Circuit (AC-AC Converter using a TRIAC)

2. b. AC TO AC Converters with Low Output Frequency or CYCLO CONVERTERS



The cyclo converters convert power from a fixed voltage fixed frequency AC supply to a variable frequency and variable AC voltage at the output.

The cyclo converters generally produce output AC voltage at a lower output frequency. That is output frequency of the AC output is less than input AC supply frequency.

Applications of cyclo converters are traction vehicles and gearless rotary kilns.

3. CHOPPERS or DC TO DC Converters

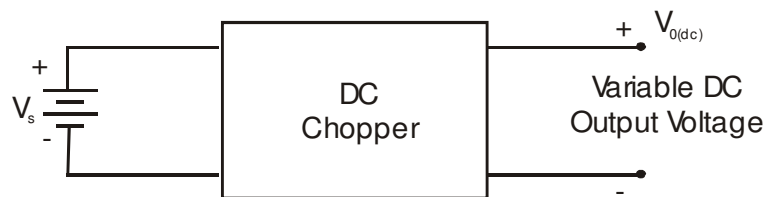

The choppers are power circuits which obtain power from a fixed voltage DC supply and convert it into a variable DC voltage. They are also called as DC choppers or DC to DC converters. Choppers employ forced commutation to turn off the Thyristors. DC choppers are further classified into several types depending on the direction of power flow and the type of commutation. DC choppers are widely used in

- Speed control of DC motors from a DC supply.
- DC drives for sub-urban traction.
- Switching power supplies.

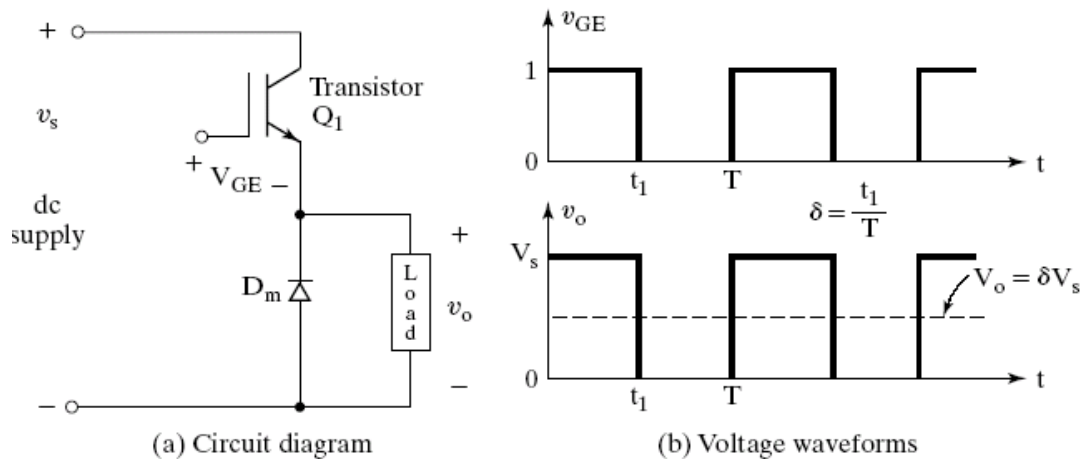
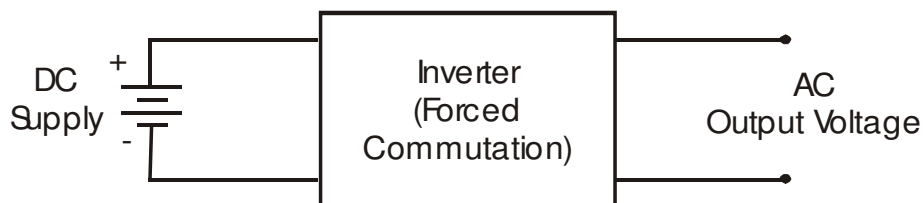

Fig.1.7: A DC Chopper Circuit (DC-DC Converter) using IGBT

4. INVERTERS or DC TO AC Converters



The inverters are used for converting DC power from a fixed voltage DC supply into an AC output voltage of variable frequency and fixed or variable output AC voltage. The inverters also employ force commutation method to turn off the Thyristors.

Applications of inverters are in

- Industrial AC drives using induction and synchronous motors.
- Uninterrupted power supplies (UPS system) used for computers, computer labs.

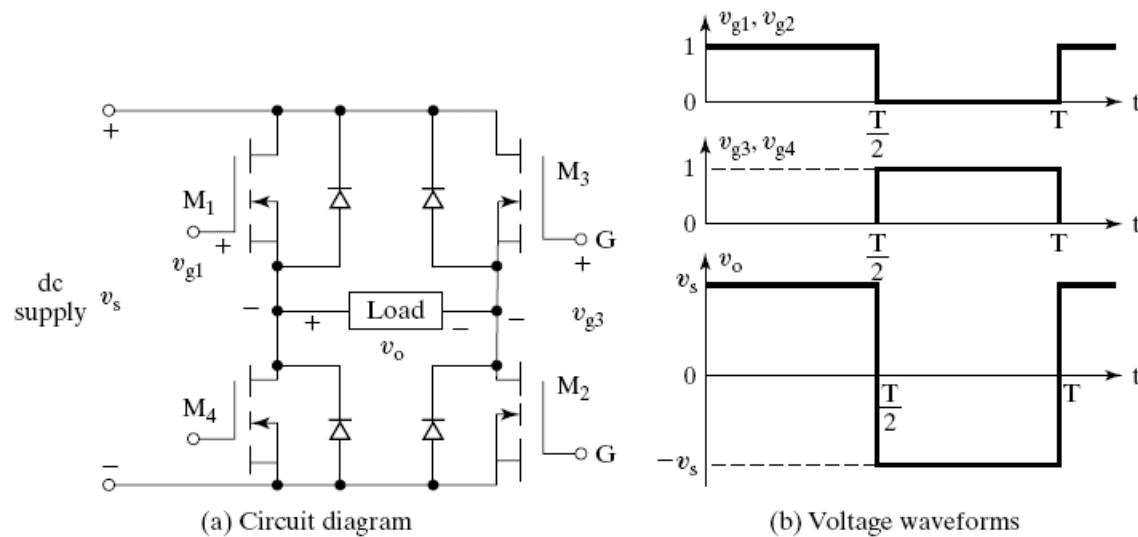

Fig.1.8: Single Phase DC-AC Converter (Inverter) using MOSFETS

1.6 Peripheral Effects

The power converter operations are based mainly on the switching of power semiconductor devices and as a result the power converters introduce current and voltage harmonics (unwanted AC signal components) into the supply system and on the output of the converters.

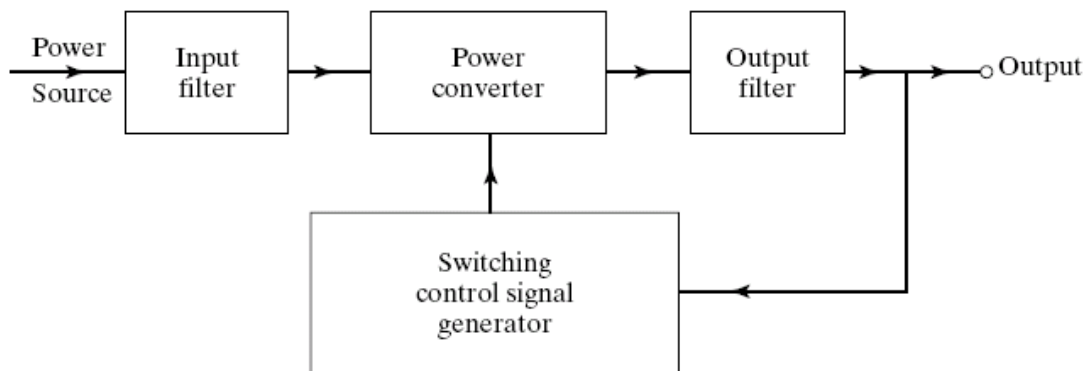

Fig.1.9: A General Power Converter System

These induced harmonics can cause problems of distortion of the output voltage, harmonic generation into the supply system, and interference with the communication and signaling circuits. It is normally necessary to introduce filters on the input side and output side of a power converter system so as to reduce the harmonic level to an acceptable magnitude. The figure below shows the block diagram of a generalized power converter with filters added. The application of power electronics to supply the sensitive electronic loads poses a challenge on the power quality issues and raises the problems and concerns to be resolved by the researchers. The input and output quantities of power converters could be either AC or DC. Factors such as total harmonic distortion (THD), displacement factor or harmonic factor

(HF), and input power factor (IPF), are measures of the quality of the waveforms. To determine these factors it is required to find the harmonic content of the waveforms. To evaluate the performance of a converter, the input and output voltages/currents of a converter are expressed in Fourier series. The quality of a power converter is judged by the quality of its voltage and current waveforms.

The control strategy for the power converters plays an important part on the harmonic generation and the output waveform distortion and can be aimed to minimize or reduce these problems. The power converters can cause radio frequency interference due to electromagnetic radiation and the gating circuits may generate erroneous signals. This interference can be avoided by proper grounding and shielding.

Recommended questions:

1. State important applications of power electronics
2. What is a static power converter? Name the different types of power converters and mention their functions.
3. Give the list of power electronic circuits of different input / output requirements.
4. What are the peripheral effects of power electronic equipments? What are the remedies for them?
5. What are the peripheral effects of power electronic equipments? What are the remedies for them?

UNIT-2

POWER TRANSISTORS

Power transistors are devices that have controlled turn-on and turn-off characteristics. These devices are used as switching devices and are operated in the saturation region resulting in low on-state voltage drop. They are turned on when a current signal is given to base or control terminal. The transistor remains on so long as the control signal is present. The switching speed of modern transistors is much higher than that of Thyristors and are used extensively in dc-dc and dc-ac converters. However their voltage and current ratings are lower than those of thyristors and are therefore used in low to medium power applications.

Power transistors are classified as follows

- Bipolar junction transistors(BJTs)
- Metal-oxide semiconductor field-effect transistors(MOSFETs)
- Static Induction transistors(SITs)
- Insulated-gate bipolar transistors(IGBTs)

2.1 Bipolar Junction Transistors

The need for a large blocking voltage in the off state and a high current carrying capability in the on state means that a power BJT must have substantially different structure than its small signal equivalent. The modified structure leads to significant differences in the I-V characteristics and switching behavior between power transistors and its logic level counterpart.

2.1.1 Power Transistor Structure

If we recall the structure of conventional transistor we see a thin p-layer is sandwiched between two n-layers or vice versa to form a three terminal device with the terminals named as Emitter, Base and Collector. The structure of a power transistor is as shown below.

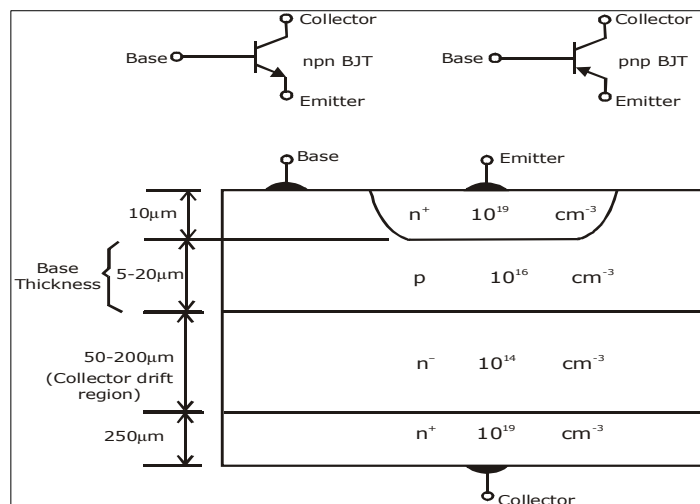

Fig.2.1: Structure of Power Transistor

The difference in the two structures is obvious.

A power transistor is a vertically oriented four layer structure of alternating p-type and n-type. The vertical structure is preferred because it maximizes the cross sectional area and through which the current in the device is flowing. This also minimizes on-state resistance and thus power dissipation in the transistor.

The doping of emitter layer and collector layer is quite large typically 10^{19} cm^{-3} . A special layer called the collector drift region (n^-) has a light doping level of 10^{14} .

The thickness of the drift region determines the breakdown voltage of the transistor. The base thickness is made as small as possible in order to have good amplification capabilities, however if the base thickness is small the breakdown voltage capability of the transistor is compromised.

2.1.2 Steady State Characteristics

Figure 3(a) shows the circuit to obtain the steady state characteristics. Fig 3(b) shows the input characteristics of the transistor which is a plot of I_B versus V_{BE} . Fig 3(c) shows the output characteristics of the transistor which is a plot I_C versus V_{CE} . The characteristics shown are that for a signal level transistor.

The power transistor has steady state characteristics almost similar to signal level transistors except that the V-I characteristics has a region of quasi saturation as shown by figure 4.

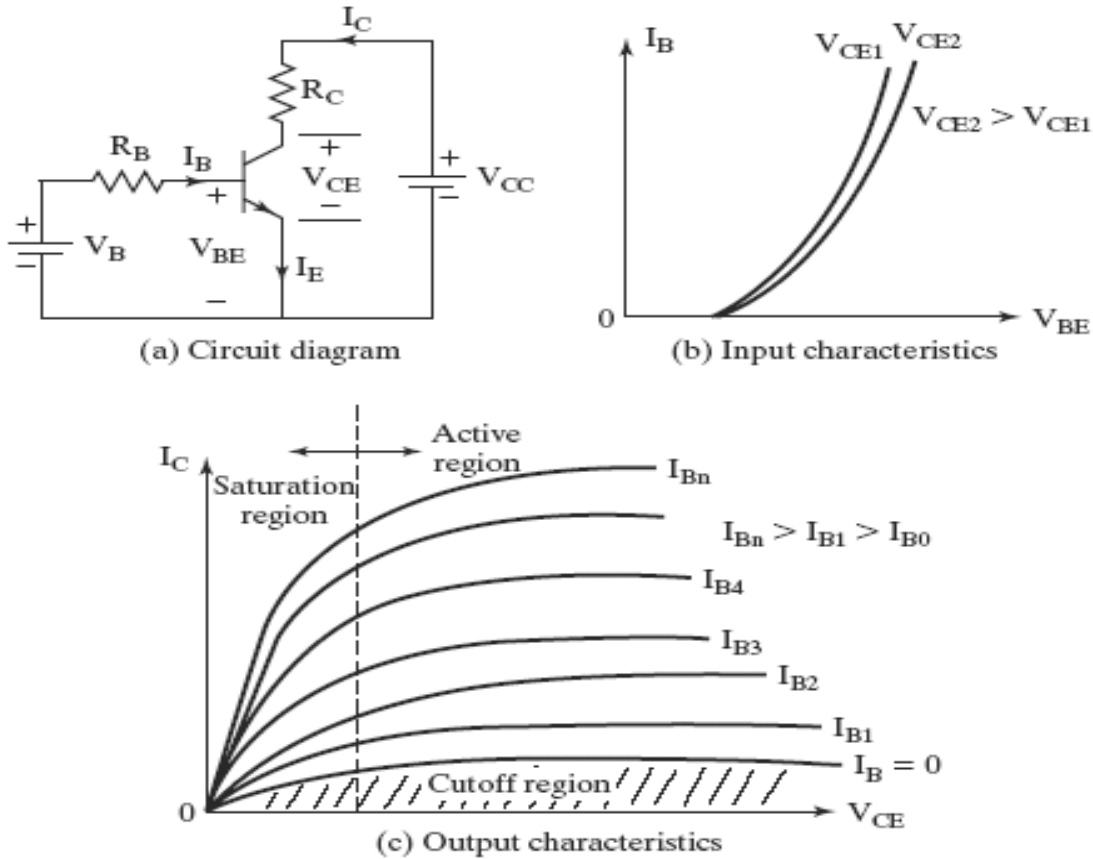

Fig 2.2. Steady State Characteristics of Power Transistor

There are four regions clearly shown: Cutoff region, Active region, quasi saturation and hard saturation. The cutoff region is the area where base current is almost zero. Hence no collector current flows and transistor is off. In the quasi saturation and hard saturation, the base drive is applied and transistor is said to be on. Hence collector current flows depending upon the load.

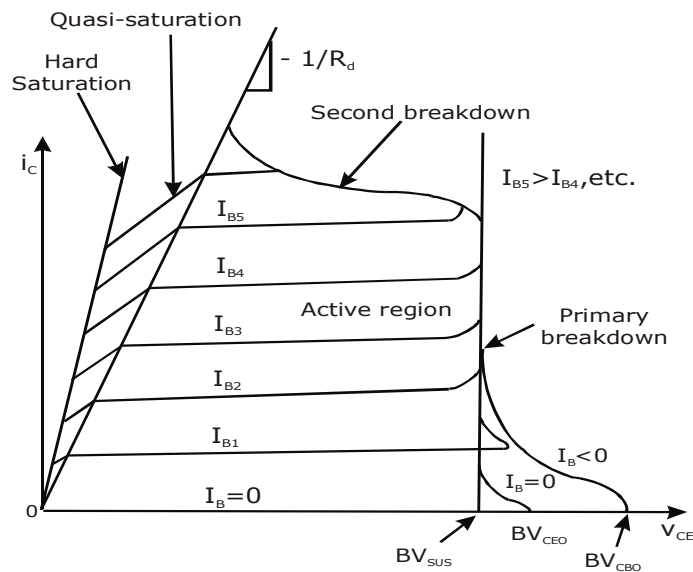

Fig. 2.3: Characteristics of NPN Power Transistors

The power BJT is never operated in the active region (i.e. as an amplifier) it is always operated between cutoff and saturation. The BV_{SUS} is the maximum collector to emitter voltage that can be sustained when BJT is carrying substantial collector current. The BV_{CEO} is the maximum collector to emitter breakdown voltage that can be sustained when base current is zero and BV_{CBO} is the collector base breakdown voltage when the emitter is open circuited.

The primary breakdown shown takes place because of avalanche breakdown of collector base junction. Large power dissipation normally leads to primary breakdown.

The second breakdown shown is due to localized thermal runaway.

Transfer Characteristics

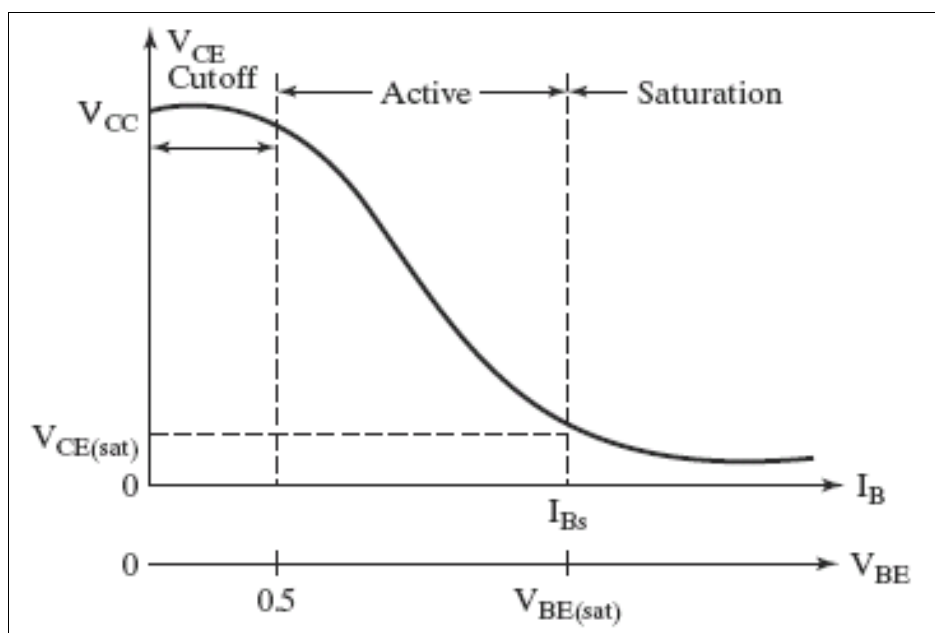

Fig. 2.4: Transfer Characteristics

$$I_E = I_C + I_B$$

$$\beta = h_{FE} = \frac{I_C}{I_B}$$

$$I_C = \beta I_B + I_{CEO}$$

$$\alpha = \frac{\beta}{\beta + 1}$$

$$\beta = \frac{\alpha}{1 - \alpha}$$

2.2 Transistor as a Switch

The transistor is used as a switch therefore it is used only between saturation and cutoff.

From fig. 5 we can write the following equations

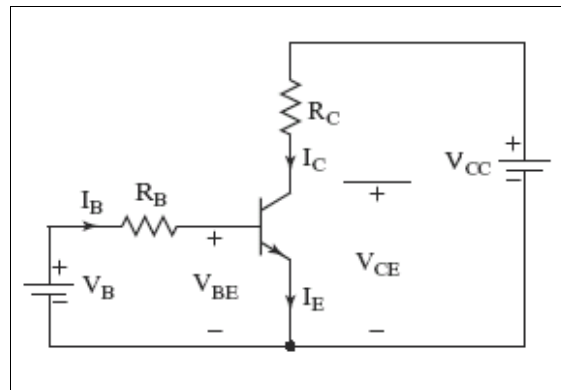

Fig. 2.5: Transistor Switch

$$I_B = \frac{V_B - V_{BE}}{R_B}$$

$$V_C = V_{CE} = V_{CC} - I_C R_C$$

$$V_C = V_{CC} - \beta \frac{R_C (V_B - V_{BE})}{R_B}$$

$$V_{CE} = V_{CB} + V_{BE}$$

$$V_{CB} = V_{CE} - V_{BE} \quad \dots(1)$$

Equation (1) shows that as long as $V_{CE} > V_{BE}$ the CBJ is reverse biased and transistor is in active region, The maximum collector current in the active region, which can be obtained by setting $V_{CB} = 0$ and $V_{BE} = V_{CE}$ is given as

$$I_{CM} = \frac{V_{CC} - V_{CE}}{R_C} \quad \therefore \quad I_{BM} = \frac{I_{CM}}{\beta_F}$$

If the base current is increased above I_{BM} , V_{BE} increases, the collector current increases and V_{CE} falls below V_{BE} . This continues until the CBJ is forward biased with V_{BC} of about 0.4 to 0.5V, the transistor then goes into saturation. The transistor saturation may be defined as the point above which any increase in the base current does not increase the collector current significantly.

In saturation, the collector current remains almost constant. If the collector emitter voltage is $V_{CE(sat)}$ the collector current is

$$I_{CS} = \frac{V_{CC} - V_{CESAT}}{R_C}$$

$$I_{BS} = \frac{I_{CS}}{\beta}$$

Normally the circuit is designed so that I_B is higher than I_{BS} . The ratio of I_B to I_{BS} is called overdrive factor ODF.

$$ODF = \frac{I_B}{I_{BS}}$$

The ratio of I_{CS} to I_B is called as forced β .

$$\beta_{forced} = \frac{I_{CS}}{I_B}$$

The total power loss in the two functions is

$$P_T = V_{BE}I_B + V_{CE}I_C$$

A high value of ODF cannot reduce the CE voltage significantly. However V_{BE} increases due to increased base current resulting in increased power loss. Once the transistor is saturated, the CE voltage is not reduced in relation to increase in base current. However the power is increased at a high value of ODF, the transistor may be damaged due to thermal runaway. On the other hand if the transistor is under driven ($I_B < I_{BS}$) it may operate in active region, V_{CE} increases resulting in increased power loss.

Problems

1. The BJT is specified to have a range of 8 to 40. The load resistance in $R_e = 11\Omega$. The dc supply voltage is $V_{CC}=200V$ and the input voltage to the base circuit is $V_B=10V$. If $V_{CE(sat)}=1.0V$ and $V_{BE(sat)}=1.5V$. Find
 - a. The value of R_B that results in saturation with a overdrive factor of 5.
 - b. The forced β_f .
 - c. The power loss P_T in the transistor.

Solution

$$(a) \quad I_{CS} = \frac{V_{CC} - V_{CE(sat)}}{R_C} = \frac{200 - 1.0}{11\Omega} = 18.1A$$

$$\text{Therefore} \quad I_{BS} = \frac{I_{CS}}{\beta_{min}} = \frac{18.1}{8} = 2.2625A$$

$$\text{Therefore} \quad I_B = ODF \times I_{BS} = 11.3125A$$

$$I_B = \frac{V_B - V_{BE(sat)}}{R_B}$$

Therefore
$$R_B = \frac{V_B - V_{BE(sat)}}{I_B} = \frac{10 - 1.5}{11.3125} = 0.715\Omega$$

(b) Therefore
$$\beta_f = \frac{I_{CS}}{I_B} = \frac{18.1}{11.3125} = 1.6$$

(c)
$$P_T = V_{BE}I_B + V_{CE}I_C$$

$$P_T = 1.5 \times 11.3125 + 1.0 \times 18.1$$

$$P_T = 16.97 + 18.1 = 35.07W$$

2. The β of a bipolar transistor varies from 12 to 75. The load resistance is $R_C = 1.5\Omega$. The dc supply voltage is $V_{CC} = 40V$ and the input voltage base circuit is $V_B = 6V$. If $V_{CE(sat)} = 1.2V$, $V_{BE(sat)} = 1.6V$ and $R_B = 0.7\Omega$ determine
- The overdrive factor ODF.
 - The forced β_f .
 - Power loss in transistor P_T

Solution

$$I_{CS} = \frac{V_{CC} - V_{CE(sat)}}{R_C} = \frac{40 - 1.2}{1.5} = 25.86A$$

$$I_{BS} = \frac{I_{CS}}{\beta_{\min}} = \frac{25.86}{12} = 2.15A$$

Also
$$I_B = \frac{V_B - V_{BE(sat)}}{R_B} = \frac{6 - 1.6}{0.7} = 6.28A$$

(a) Therefore
$$ODF = \frac{I_B}{I_{BS}} = \frac{6.28}{2.15} = 2.92$$

Forced
$$\beta_f = \frac{I_{CS}}{I_B} = \frac{25.86}{6.28} = 4.11$$

(c)
$$P_T = V_{BE}I_B + V_{CE}I_C$$

$$P_T = 1.6 \times 6.25 + 1.2 \times 25.86$$

$$P_T = 41.032Watts$$

3. For the transistor switch as shown in figure
- Calculate forced beta, β_f of transistor.
 - If the manufacturers specified β is in the range of 8 to 40, calculate the minimum overdrive factor (ODF).
 - Obtain power loss P_T in the transistor.

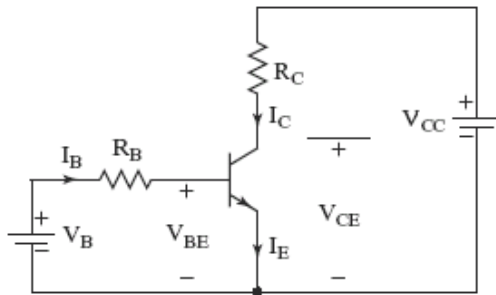

$$V_B = 10V, \quad R_B = 0.75\Omega,$$

$$V_{BE(sat)} = 1.5V, \quad R_C = 11\Omega,$$

$$V_{CE(sat)} = 1V, \quad V_{CC} = 200V$$

Solution

$$(i) \quad I_B = \frac{V_B - V_{BE(sat)}}{R_B} = \frac{10 - 1.5}{0.75} = 11.33A$$

$$I_{CS} = \frac{V_{CC} - V_{CE(sat)}}{R_C} = \frac{200 - 1.0}{11} = 18.09A$$

$$\text{Therefore} \quad I_{BS} = \frac{I_{CS}}{\beta_{\min}} = \frac{18.09}{8} = 2.26A$$

$$\beta_f = \frac{I_{CS}}{I_B} = \frac{18.09}{11.33} = 1.6$$

$$(ii) \quad ODF = \frac{I_B}{I_{BS}} = \frac{11.33}{2.26} = 5.01$$

$$(iii) \quad P_T = V_{BE}I_B + V_{CE}I_C = 1.5 \times 11.33 + 1.0 \times 18.09 = 35.085W$$

4. A simple transistor switch is used to connect a 24V DC supply across a relay coil, which has a DC resistance of 200 Ω . An input pulse of 0 to 5V amplitude is applied through series base resistor R_B at the base so as to turn on the transistor switch. Sketch the device current waveform with reference to the input pulse.

Calculate

- I_{CS} .
- Value of resistor R_B , required to obtain over drive factor of two.

- c. Total power dissipation in the transistor that occurs during the saturation state.

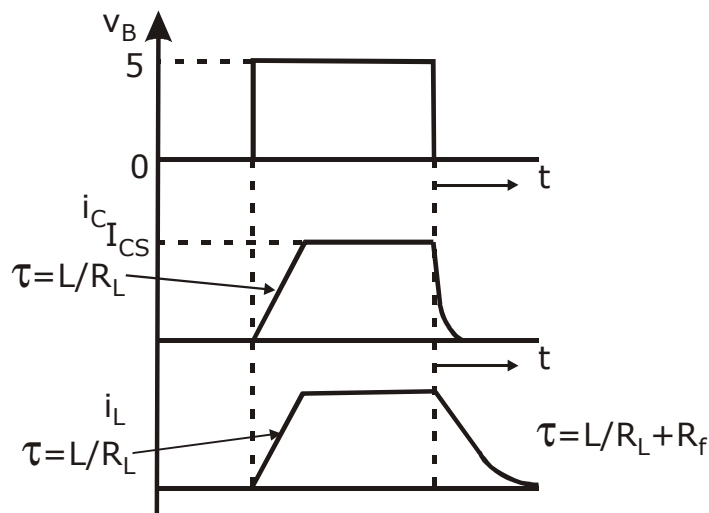
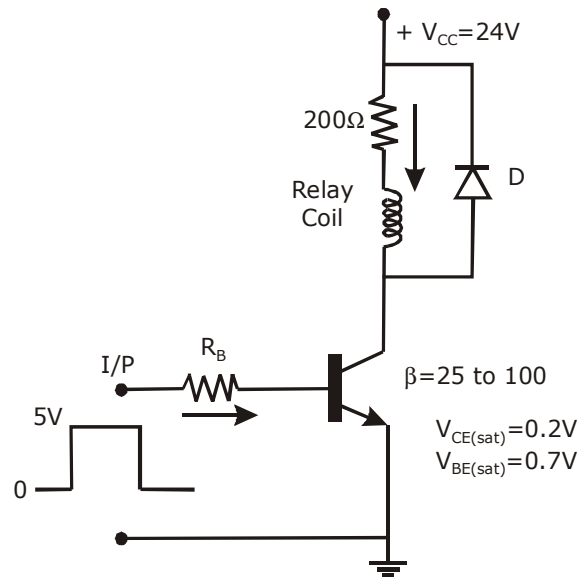

Solution

To sketch the device current waveforms; current through the device cannot rise fast to the saturating level of I_{CS} since the inductive nature of the coil opposes any change in current through it. Rate of rise of collector current can be determined by the time constant $\tau_1 = \frac{L}{R}$. Where L is inductive in Henry of coil and R is resistance of coil. Once steady state value of I_{CS} is reached the coil acts as a short circuit. The collector current stays put at I_{CS} till the base pulse is present.

Similarly once input pulse drops to zero, the current I_C does not fall to zero immediately since inductor will now act as a current source. This current will now decay at the fall to zero. Also the current has an alternate path and now can flow through the diode.

$$(i) \quad I_{CS} = \frac{V_{CC} - V_{CE(sat)}}{R_C} = \frac{24 - 0.2}{200} = 0.119A$$

(ii) Value of R_B

$$I_{BS} = \frac{I_{CS}}{\beta_{\min}} = \frac{0.119}{25} = 4.76mA$$

$$\therefore I_B = ODF \times I_{BS} = 2 \times 4.76 = 9.52mA$$

$$\therefore R_B = \frac{V_B - V_{BE(sat)}}{I_B} = \frac{5 - 0.7}{9.52} = 450\Omega$$

$$(iii) \quad P_T = V_{BE(sat)} \times I_B + V_{CE(sat)} \times I_{CS} = 0.7 \times 9.52 + 0.2 \times 0.119 = 6.68W$$

Switching Characteristics

A forward biased p-n junction exhibits two parallel capacitances; a depletion layer capacitance and a diffusion capacitance. On the other hand, a reverse biased p-n junction has only depletion capacitance. Under steady state the capacitances do not play any role. However under transient conditions, they influence turn-on and turn-off behavior of the transistor.

2.3 Transient Model of BJT

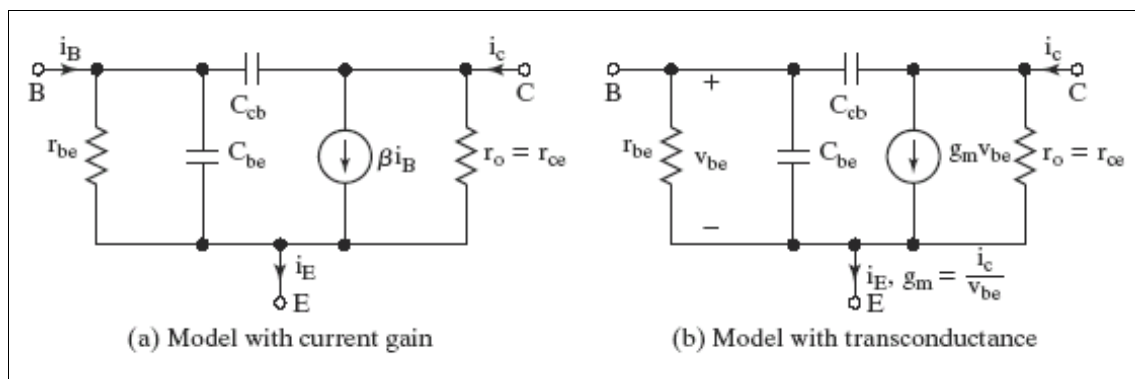

Fig. 2.6: Transient Model of BJT

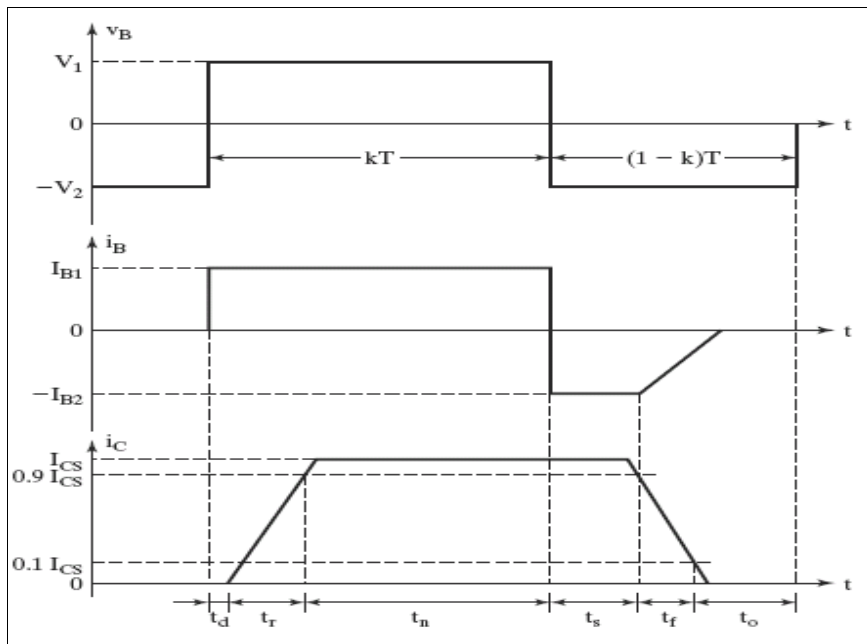

Fig. 2.7: Switching Times of BJT

Due to internal capacitances, the transistor does not turn on instantly. As the voltage V_B rises from zero to V_1 and the base current rises to I_{B1} , the collector current does not respond immediately. There is a delay known as delay time t_d , before any collector current flows. The delay is due to the time required to charge up the BEJ to the forward bias voltage $V_{BE}(0.7V)$. The collector current rises to the steady value of I_{CS} and this time is called rise time t_r .

The base current is normally more than that required to saturate the transistor. As a result excess minority carrier charge is stored in the base region. The higher the ODF, the greater is the amount of extra charge stored in the base. This extra charge which is called the saturating charge is proportional to the excess base drive.

This extra charge which is called the saturating charge is proportional to the excess base drive and the corresponding current I_e .

$$I_e = I_B - \frac{I_{CS}}{\beta} = ODF \cdot I_{BS} - I_{BS} = I_{BS} (ODF - 1)$$

Saturating charge $Q_s = \tau_s I_e = \tau_s I_{BS} (ODF - 1)$ where τ_s is known as the storage time constant.

When the input voltage is reversed from V_1 to $-V_2$, the reverse current $-I_{B2}$ helps to discharge the base. Without $-I_{B2}$ the saturating charge has to be removed entirely due to recombination and the storage time t_s would be longer.

Once the extra charge is removed, BEJ charges to the input voltage $-V_2$ and the base current falls to zero. t_f depends on the time constant which is determined by the reverse biased BEJ capacitance.

$$\therefore \quad t_{on} = t_d + t_r$$

$$t_{off} = t_s + t_f$$

Problems

1. For a power transistor, typical switching waveforms are shown. The various parameters of the transistor circuit are as under $V_{cc} = 220V$, $V_{CE(sat)} = 2V$, $I_{CS} = 80A$, $t_d = 0.4\mu s$, $t_r = 1\mu s$, $t_n = 50\mu s$, $t_s = 3\mu s$, $t_f = 2\mu s$, $t_0 = 40\mu s$, $f = 5Khz$, $I_{CEO} = 2mA$. Determine average power loss due to collector current during t_{on} and t_n . Find also the peak instantaneous power loss, due to collector current during turn-on time.

Solution

During delay time, the time limits are $0 \leq t \leq t_d$. Figure shows that in this time $i_c(t) = I_{CEO}$ and $V_{CE}(t) = V_{CC}$. Therefore instantaneous power loss during delay time is $P_d(t) = i_c V_{CE} = I_{CEO} V_{CC} = 2 \times 10^{-3} \times 220 = 0.44W$

Average power loss during delay time $0 \leq t \leq t_d$ is given by

$$Pd = \frac{1}{T} \int_0^{t_d} i_c(t) v_{CE}(t) dt$$

$$Pd = \frac{1}{T} \int_0^{t_d} I_{CEO} V_{CC} dt$$

$$Pd = f \cdot I_{CEO} V_{CC} t_d$$

$$Pd = 5 \times 10^3 \times 2 \times 10^{-3} \times 220 \times 0.4 \times 10^{-6} = 0.88mW$$

During rise time $0 \leq t \leq t_r$,

$$i_c(t) = \frac{I_{CS}}{t_r} t$$

$$v_{CE}(t) = \left[V_{CC} - \left(\frac{V_{CC} - V_{CE(sat)}}{t_r} \right) t \right]$$

$$v_{CE}(t) = V_{CC} + \left[V_{CE(sat)} - V_{CC} \right] \frac{t}{t_r}$$

Therefore average power loss during rise time is

$$P_r = \frac{1}{T} \int_0^{t_r} \frac{I_{CS}}{t_r} t \left[V_{CC} + (V_{CE(sat)} - V_{CC}) \frac{t}{t_r} \right] dt$$

$$P_r = f \cdot I_{CS} t_r \left[\frac{V_{CC}}{2} - \frac{V_{CC} - V_{CES}}{3} \right]$$

$$P_r = 5 \times 10^3 \times 80 \times 1 \times 10^{-6} \left[\frac{220}{2} - \frac{220 - 2}{3} \right] = 14.933W$$

Instantaneous power loss during rise time is

$$P_r(t) = \frac{I_{CS}}{t_r} t \left[V_{CC} - \frac{V_{CC} - V_{CE(sat)}}{t_r} t \right]$$

$$P_r(t) = \frac{I_{CS}}{t_r} t V_{CC} - \frac{I_{CS}^2}{t_r^2} \left[V_{CC} - V_{CE(sat)} \right]$$

Differentiating the above equation and equating it to zero will give the time t_m at which instantaneous power loss during t_r would be maximum.

Therefore
$$\frac{dP_r(t)}{dt} = \frac{I_{CS} V_{CC}}{t_r} - \frac{I_{CS} 2t}{t_r^2} [V_{CC} - V_{CE(sat)}]$$

At $t = t_m$,
$$\frac{dP_r(t)}{dt} = 0$$

Therefore
$$0 = \frac{I_{CS}}{t_r} V_{CC} - \frac{2I_{CS} t_m}{t_r^2} [V_{CC} - V_{CE(sat)}]$$

$$\frac{I_{CS}}{t_r} V_{CC} = \frac{2I_{CS} t_m}{t_r^2} [V_{CC} - V_{CE(sat)}]$$

$$\frac{t_r V_{CC}}{2} = t_m [V_{CC} - V_{CE(sat)}]$$

Therefore
$$t_m = \frac{t_r V_{CC}}{2 [V_{CC} - V_{CE(sat)}]}$$

Therefore
$$t_m = \frac{V_{CC} t_r}{2 [V_{CC} - V_{CE(sat)}]} = \frac{220 \times 1 \times 10^{-6}}{2 [200 - 2]} = 0.5046 \mu s$$

Peak instantaneous power loss P_m during rise time is obtained by substituting the value of $t=t_m$ in equation (1) we get

$$P_{m} = \frac{I_{CS}}{t_r} \frac{V_{CC}^2 t_r}{2[V_{CC} - V_{CE(sat)}]} - \frac{I_{CS}}{t_r^2} \frac{(V_{CC} t_r)^2 [V_{CC} - V_{CE(sat)}]}{4[V_{CC} - V_{CE(sat)}]^2}$$

$$P_{m} = \frac{80 \times 220^2}{4[220 - 2]} = 4440.4W$$

Total average power loss during turn-on

$$P_{on} = P_d + P_r = 0.00088 + 14.933 = 14.9339W$$

During conduction time $0 \leq t \leq t_n$

$$i_c(t) = I_{CS} \text{ \& } v_{CE}(t) = V_{CE(sat)}$$

Instantaneous power loss during t_n is

$$P_n(t) = i_c v_{CE} = I_{CS} V_{CE(sat)} = 80 \times 2 = 160W$$

Average power loss during conduction period is

$$P_n = \frac{1}{T} \int_0^{t_n} i_c v_{CE} dt = f I_{CS} V_{CES} t_n = 5 \times 10^3 \times 80 \times 2 \times 50 \times 10^{-6} = 40W$$

2.4 Switching Limits

1. Second Breakdown

It is a destructive phenomenon that results from the current flow to a small portion of the base, producing localized hot spots. If the energy in these hot spots is sufficient the excessive localized heating may damage the transistor. Thus secondary breakdown is caused by a localized thermal runaway. The SB occurs at certain combinations of voltage, current and time. Since time is involved, the secondary breakdown is basically an energy dependent phenomenon.

2. Forward Biased Safe Operating Area FBSOA

During turn-on and on-state conditions, the average junction temperature and second breakdown limit the power handling capability of a transistor. The manufacturer usually provides the FBSOA curves under specified test conditions. FBSOA indicates the $I_c - V_{ce}$ limits of the transistor and for reliable operation the transistor must not be subjected to greater power dissipation than that shown by the FBSOA curve.

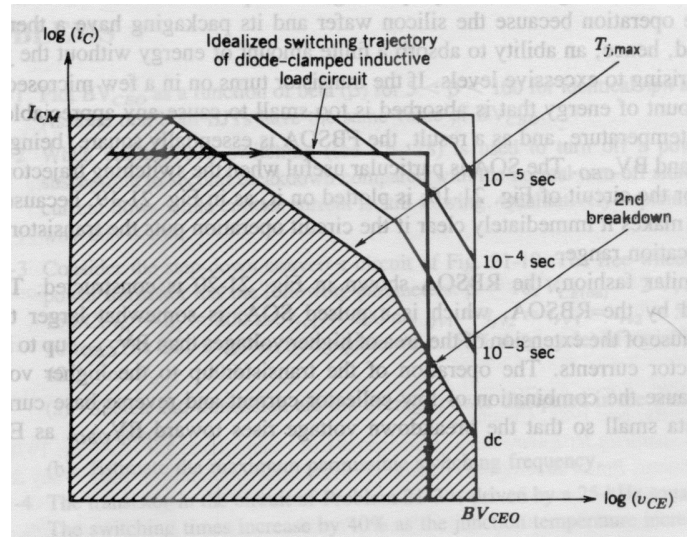

The dc FBSOA is shown as shaded area and the expansion of the area for pulsed operation of the BJT with shorter switching times which leads to larger FBSOA. The second break down boundary represents the maximum permissible combinations of voltage and current without getting into the region of $i_c - v_{ce}$ plane where second breakdown may occur. The final portion of the boundary of the FBSOA is breakdown voltage limit BV_{CEO} .

3. Reverse Biased Safe Operating Area RBSOA

During turn-off, a high current and high voltage must be sustained by the transistor, in most cases with the base-emitter junction reverse biased. The collector emitter voltage must be held to a safe level at or below a specified value of collector current. The manufacturer provide $I_c - V_{ce}$ limits during reverse-biased turn off as reverse biased safe area (RBSOA).

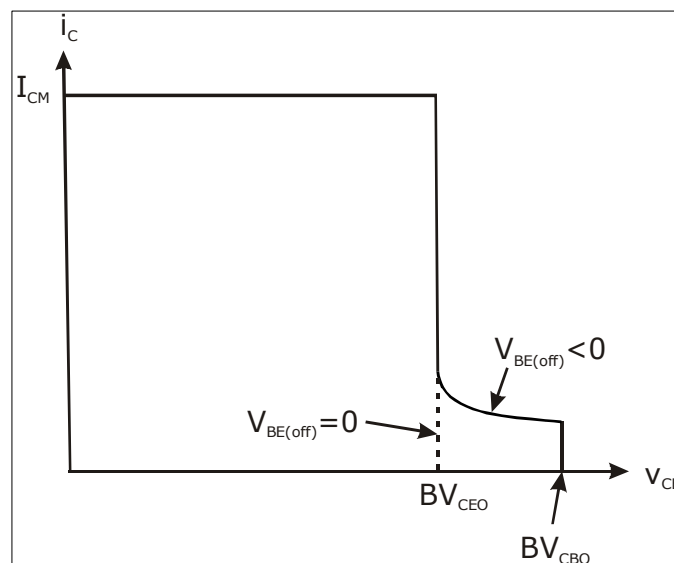

Fig.2.8: RBSOA of a Power BJT

The area encompassed by the RBSOA is somewhat larger than FBSOA because of the extension of the area of higher voltages than BV_{CEO} upto BV_{CBO} at low collector currents.

This operation of the transistor upto higher voltage is possible because the combination of low collector current and reverse base current has made the beta so small that break down voltage rises towards BV_{CBO} .

4. Power Derating

The thermal equivalent is shown. If the total average power loss is P_T ,

$$\text{The case temperature is } T_c = T_j - P_T R_{jc}.$$

$$\text{The sink temperature is } T_s = T_c - P_T R_{cs}$$

$$\text{The ambient temperature is } T_A = T_s - P_T R_{sA} \text{ and } T_j - T_A = P_T (R_{jc} + R_{cs} + R_{sA})$$

R_{jc} : Thermal resistance from junction to case $^{\circ}\text{C}/\omega$.

R_{cs} : Thermal resistance from case to sink $^{\circ}\text{C}/\omega$.

R_{sA} : Thermal resistance from sink to ambient $^{\circ}\text{C}/\omega$.

The maximum power dissipation in P_T is specified at $T_C = 25^{\circ}\text{C}$.

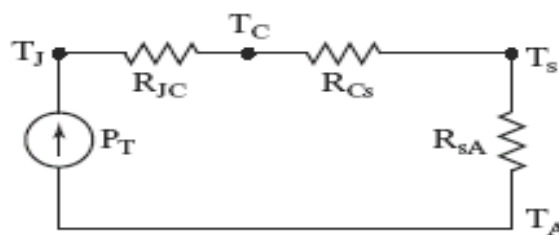

Fig.2.9: Thermal Equivalent Circuit of Transistor

5. Breakdown Voltages

A break down voltage is defined as the absolute maximum voltage between two terminals with the third terminal open, shorted or biased in either forward or reverse direction.

BV_{SUS} : The maximum voltage between the collector and emitter that can be sustained across the transistor when it is carrying substantial collector current.

BV_{CEO} : The maximum voltage between the collector and emitter terminal with base open circuited.

BV_{CBO} : This is the collector to base break down voltage when emitter is open circuited.

6. Base Drive Control

This is required to optimize the base drive of transistor. Optimization is required to increase switching speeds. t_{on} can be reduced by allowing base current peaking during turn-

on, $\left(\beta_F = \frac{I_{CS}}{I_B} [\text{forced } \beta] \right)$ resulting in low forces β at the beginning. After turn on, β_F can be increased to a sufficiently high value to maintain the transistor in quasi-saturation region. t_{off} can be reduced by reversing base current and allowing base current peaking during turn off since increasing I_{B2} decreases storage time.

A typical waveform for base current is shown.

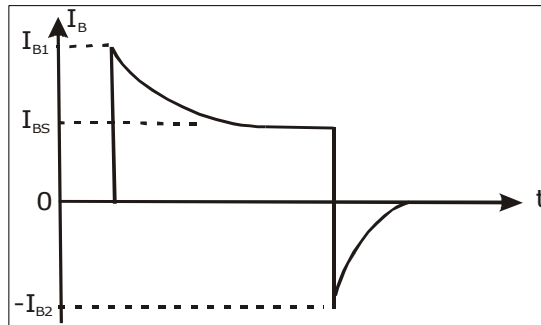

Fig.2.10: Base Drive Current Waveform

Some common types of optimizing base drive of transistor are

- Turn-on Control.
- Turn-off Control.
- Proportional Base Control.
- Antisaturation Control

Turn-On Control

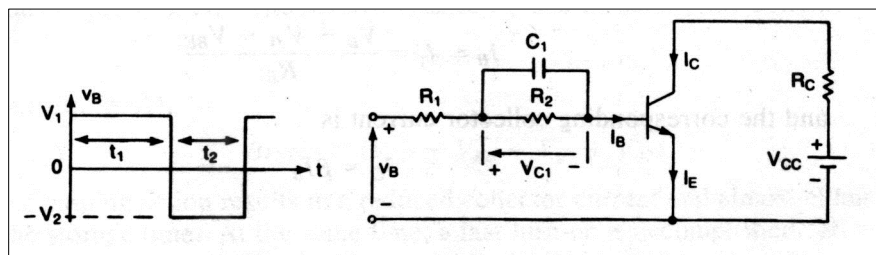

Fig. 2.11: Base current peaking during turn-on

When input voltage is turned on, the base current is limited by resistor R_1 and therefore initial value of base current is $I_{BO} = \frac{V_1 - V_{BE}}{R_1}$, $I_{BF} = \frac{V_1 - V_{BE}}{R_1 + R_2}$.

Capacitor voltage $V_C = V_1 \frac{R_2}{R_1 + R_2}$.

Therefore
$$\tau_1 = \left(\frac{R_1 R_2}{R_1 + R_2} \right) C_1$$

Once input voltage v_B becomes zero, the base-emitter junction is reverse biased and C_1 discharges through R_2 . The discharging time constant is $\tau_2 = R_2 C_1$. To allow sufficient charging and discharging time, the width of base pulse must be $t_1 \geq 5\tau_1$ and off period of the pulse must be $t_2 \geq 5\tau_2$. The maximum switching frequency is $f_s = \frac{1}{T} = \frac{1}{t_1 + t_2} = \frac{0.2}{\tau_1 + \tau_2}$.

Turn-Off Control

If the input voltage is changed to during turn-off the capacitor voltage V_c is added to V_2 as reverse voltage across the transistor. There will be base current peaking during turn off. As the capacitor C_1 discharges, the reverse voltage will be reduced to a steady state value, V_2 . If different turn-on and turn-off characteristics are required, a turn-off circuit using (C_2, R_3 & R_4) may be added. The diode D_1 isolates the forward base drive circuit from the reverse base drive circuit during turn off.

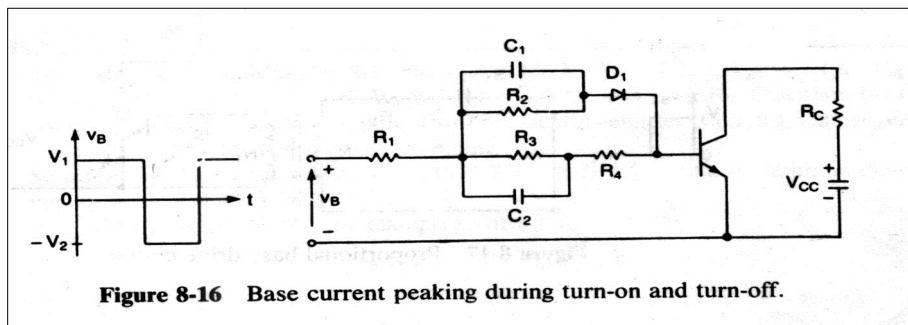

Fig: 2.12. Base current peaking during turn-on and turn-off

Proportional Base Control

This type of control has advantages over the constant drive circuit. If the collector current changes due to change in load demand, the base drive current is changed in proportion to collector current.

When switch S_1 is turned on a pulse current of short duration would flow through the base of transistor Q_1 and Q_1 is turned on into saturation. Once the collector current starts to flow, a corresponding base current is induced due to transformer action. The transistor would latch on itself and S_1 can be turned off. The turns ratio is $\frac{N_2}{N_1} = \frac{I_C}{I_B} = \beta$. For proper operation of the circuit, the magnetizing current which must be much smaller than the collector current should be as small as possible. The switch S_1 can be implemented by a small signal transistor

and additional arrangement is necessary to discharge capacitor C_1 and reset the transformer core during turn-off of the power transistor.

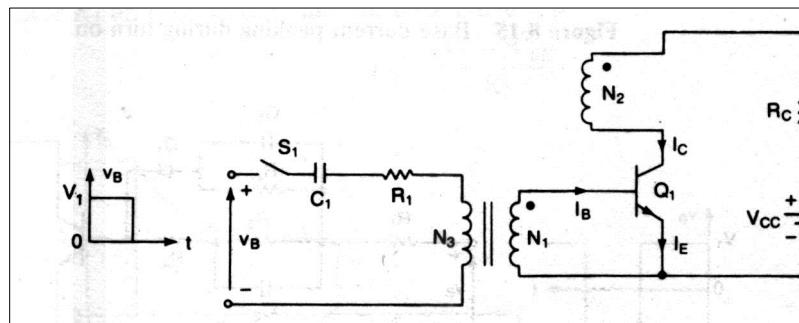

Fig.2.13: Proportional base drive circuit

Antisaturation Control

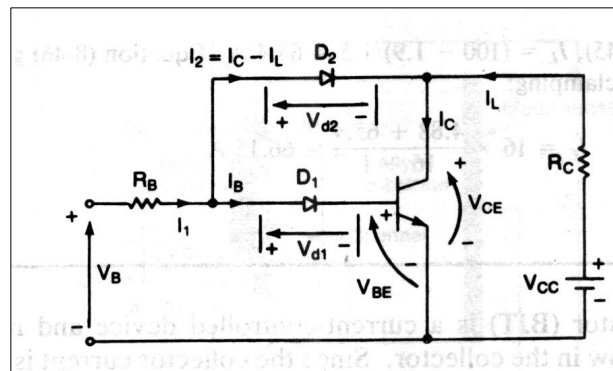

Fig.2.14: Collector Clamping Circuit

If a transistor is driven hard, the storage time which is proportional to the base current increases and the switching speed is reduced. The storage time can be reduced by operating the transistor in soft saturation rather than hard saturation. This can be accomplished by clamping CE voltage to a pre-determined level and the collector current is given by

$$I_C = \frac{V_{CC} - V_{CM}}{R_C}$$

Where V_{CM} is the clamping voltage and $V_{CM} > V_{CE(sat)}$.

The base current which is adequate to drive the transistor hard, can be found from $I_B = I_1 = \frac{V_B - V_{D1} - V_{BE}}{R_B}$ and the corresponding collector current is $I_C = I_L = \beta I_B$.

Writing the loop equation for the input base circuit,

$$V_{ab} = V_{D1} + V_{BE}$$

Similarly $V_{ab} = V_{D_2} + V_{CE}$

Therefore $V_{CE} = V_{BE} + V_{D_1} - V_{D_2}$

For clamping $V_{D_1} > V_{D_2}$

Therefore $V_{CE} = 0.7 + \dots\dots$

This means that the CE voltage is raised above saturation level and there are no excess carriers in the base and storage time is reduced.

The load current is $I_L = \frac{V_{CC} - V_{CE}}{R_C} = \frac{V_{CC} - V_{BE} - V_{D_1} + V_{D_2}}{R_C}$ and the collector current

with clamping is $I_C = \beta I_B = \beta [I_1 - I_C + I_L] = \frac{\beta}{1 + \beta} (I_1 + I_L)$

For clamping, $V_{D_1} > V_{D_2}$ and this can be accomplished by connecting two or more diodes in place of D_1 . The load resistance R_C should satisfy the condition $\beta I_B > I_L$, $\beta I_B R_C > (V_{CC} - V_{BE} - V_{D_1} + V_{D_2})$.

The clamping action thus results a reduced collector current and almost elimination of the storage time. At the same time, a fast turn-on is accomplished.

However, due to increased V_{CE} , the on-state power dissipation in the transistor is increased, whereas the switching power loss is decreased.

ADVANTAGES OF BJT'S

- BJT's have high switching frequencies since their turn-on and turn-off time is low.
- The turn-on losses of a BJT are small.
- BJT has controlled turn-on and turn-off characteristics since base drive control is possible.
- BJT does not require commutation circuits.

DEMERITS OF BJT

- Drive circuit of BJT is complex.
- It has the problem of charge storage which sets a limit on switching frequencies.

It cannot be used in parallel operation due to problems of negative temperature coefficient.

2.5 POWER MOSFETS

MOSFET stands for metal oxide semiconductor field effect transistor. There are two types of MOSFET

- Depletion type MOSFET
- Enhancement type MOSFET

2.5.1 Depletion Type MOSFET

Construction

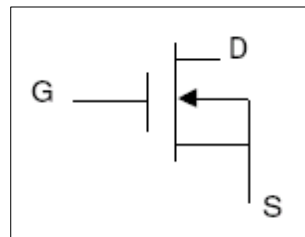

Fig.2.15 Symbol of n-channel depletion type MOSFET

It consists of a highly doped p-type substrate into which two blocks of heavily doped n-type material are diffused to form a source and drain. A n-channel is formed by diffusing between source and drain. A thin layer of SiO_2 is grown over the entire surface and holes are cut in SiO_2 to make contact with n-type blocks. The gate is also connected to a metal contact surface but remains insulated from the n-channel by the SiO_2 layer. SiO_2 layer results in an extremely high input impedance of the order of 10^{10} to $10^{15} \Omega$ for this area.

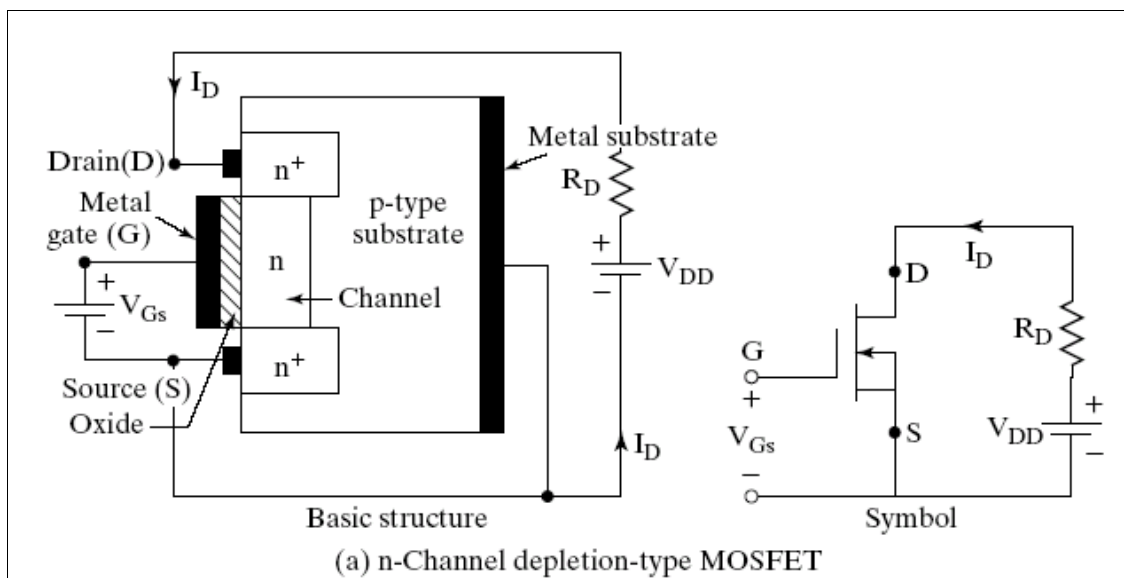

Fig.2.16: Structure of n-channel depletion type MOSFET

Operation

When $V_{GS} = 0V$ and V_{DS} is applied and current flows from drain to source similar to JFET. When $V_{GS} = -1V$, the negative potential will tend to pressure electrons towards the p-type substrate and attracts hole from p-type substrate. Therefore recombination occurs and will reduce the number of free electrons in the n-channel for conduction. Therefore with increased negative gate voltage I_D reduces.

For positive values, V_{gs} , additional electrons from p-substrate will flow into the channel and establish new carriers which will result in an increase in drain current with positive gate voltage.

Drain Characteristics

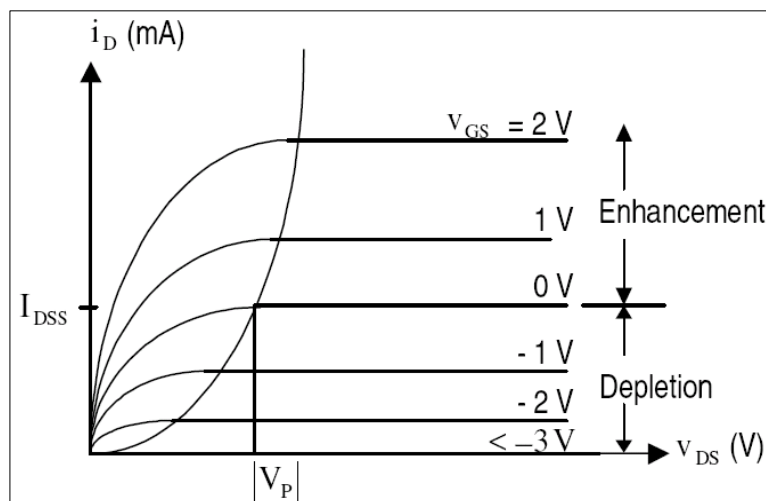

Transfer Characteristics

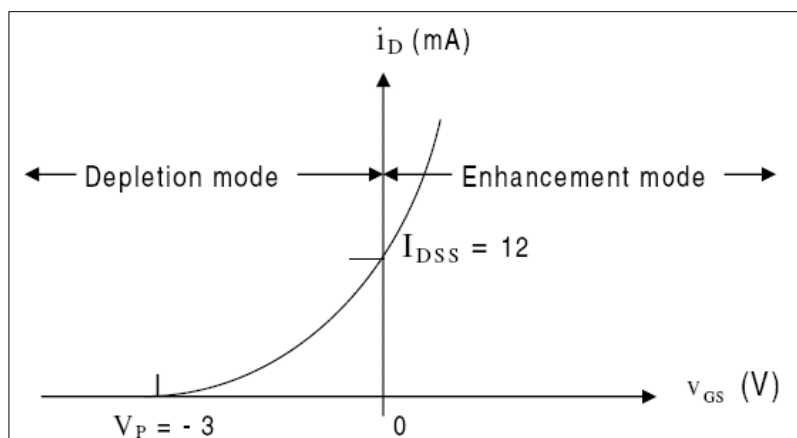

2.5.2 Enhancement Type MOSFET

Here current control in an n-channel device is now affected by positive gate to source voltage rather than the range of negative voltages of JFET's and depletion type MOSFET.

Basic Construction

A slab of p-type material is formed and two n-regions are formed in the substrate. The source and drain terminals are connected through metallic contacts to n-doped regions, but the absence of a channel between the doped n-regions. The SiO_2 layer is still present to isolate the gate metallic platform from the region between drain and source, but now it is separated by a section of p-type material.

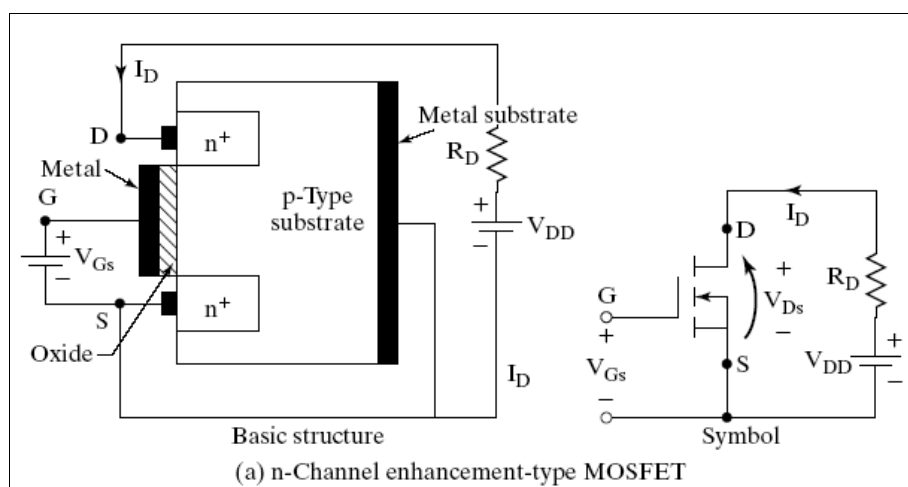

Fig. 2.17: Structure of n-channel enhancement type MOSFET

Operation

If $V_{GS} = 0V$ and a voltage is applied between the drain and source, the absence of a n-channel will result in a current of effectively zero amperes. With V_{DS} set at some positive voltage and V_{GS} set at $0V$, there are two reverse biased p-n junction between the n-doped regions and p substrate to oppose any significant flow between drain and source.

If both V_{DS} and V_{GS} have been set at some positive voltage, then positive potential at the gate will pressure the holes in the p-substrate along the edge of SiO_2 layer to leave the area and enter deeper region of p-substrate. However the electrons in the p-substrate will be attracted to the positive gate and accumulate in the region near the surface of the SiO_2 layer. The negative carriers will not be absorbed due to insulating SiO_2 layer, forming an inversion layer which results in current flow from drain to source.

The level of V_{GS} that result in significant increase in drain current is called threshold voltage V_T . As V_{GS} increases the density of free carriers will increase resulting in increased

level of drain current. If V_{GS} is constant V_{DS} is increased; the drain current will eventually reach a saturation level as occurred in JFET.

Drain Characteristics

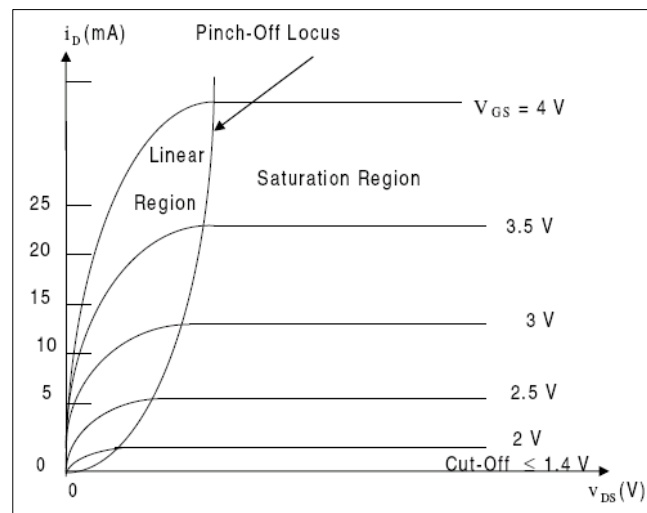

Transfer Characteristics

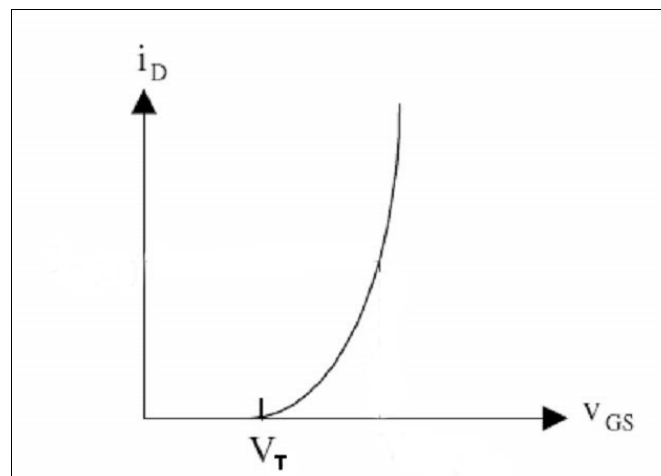

Power MOSFET'S

Power MOSFET's are generally of enhancement type only. This MOSFET is turned 'ON' when a voltage is applied between gate and source. The MOSFET can be turned 'OFF' by removing the gate to source voltage. Thus gate has control over the conduction of the MOSFET. The turn-on and turn-off times of MOSFET's are very small. Hence they operate at very high frequencies; hence MOSFET's are preferred in applications such as choppers and inverters. Since only voltage drive (gate-source) is required, the drive circuits of MOSFET are very simple. The paralleling of MOSFET's is easier due to their positive

temperature coefficient. But MOSFETs have high on-state resistance hence for higher currents; losses in the MOSFETs are substantially increased. Hence MOSFETs are used for low power applications.

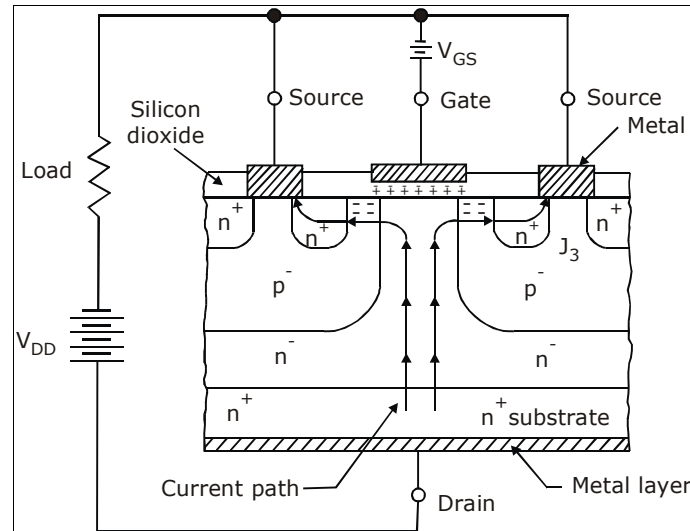

Construction

Power MOSFETs have additional features to handle larger powers. On the n^+ substrate high resistivity n^- layer is epitaxially grown. The thickness of n^- layer determines the voltage blocking capability of the device. On the other side of n^+ substrate, a metal layer is deposited to form the drain terminal. Now p^- regions are diffused in the epitaxially grown n^- layer. Further n^+ regions are diffused in the p^- regions as shown. SiO_2 layer is added, which is then etched so as to fit metallic source and gate terminals.

A power MOSFET actually consists of a parallel connection of thousands of basic MOSFET cells on the same single chip of silicon.

When gate circuit voltage is zero and V_{DD} is present, $n^+ - p^-$ junctions are reverse biased and no current flows from drain to source. When gate terminal is made positive with respect to source, an electric field is established and electrons from n^- channel in the p^- regions. Therefore a current from drain to source is established.

Power MOSFET conduction is due to majority carriers therefore time delays caused by removal of recombination of minority carriers is removed.

Because of the drift region the ON state drop of MOSFET increases. The thickness of the drift region determines the breakdown voltage of MOSFET. As seen a parasitic BJT is formed, since emitter base is shorted to source it does not conduct.

2.6 Switching Characteristics

The switching model of MOSFETs is as shown in the figure 6(a). The various inter electrode capacitance of the MOSFET which cannot be ignored during high frequency

switching are represented by C_{gs} , C_{gd} & C_{ds} . The switching waveforms are as shown in figure 7. The turn on time t_d is the time that is required to charge the input capacitance to the threshold voltage level. The rise time t_r is the gate charging time from this threshold level to the full gate voltage V_{gsp} . The turn off delay time t_{doff} is the time required for the input capacitance to discharge from overdriving the voltage V_1 to the pinch off region. The fall time is the time required for the input capacitance to discharge from pinch off region to the threshold voltage. Thus basically switching ON and OFF depend on the charging time of the input gate capacitance.

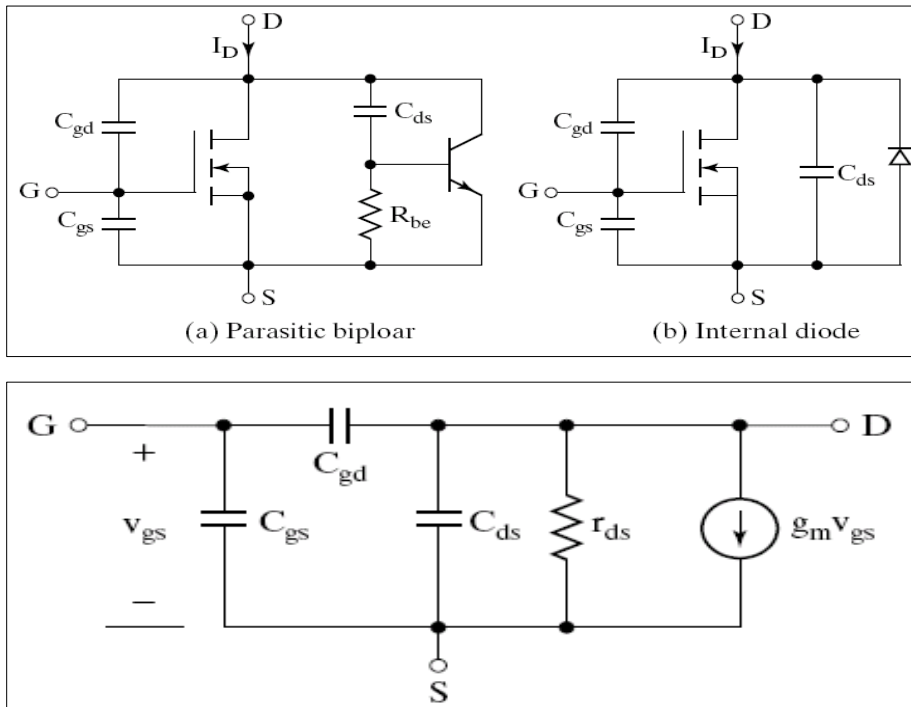

Fig.2.18: Switching model of MOSFET

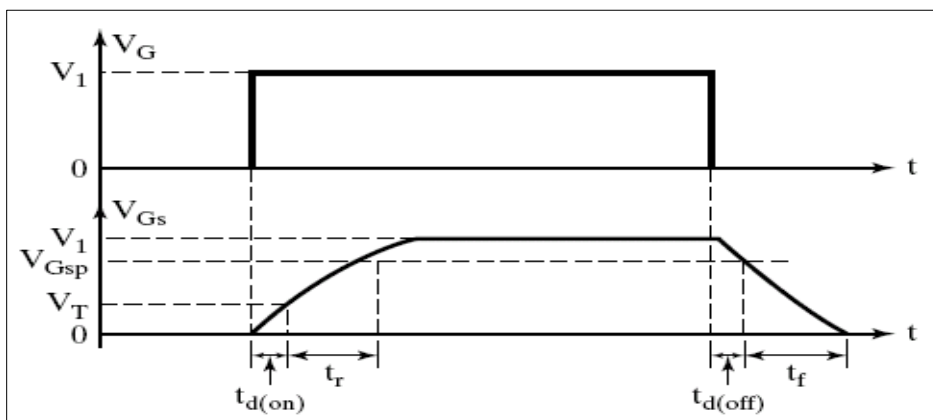

Fig2.19: Switching waveforms and times of Power MOSFET

Gate Drive

The turn-on time can be reduced by connecting a RC circuit as shown to charge the capacitance faster. When the gate voltage is turned on, the initial charging current of the capacitance is

$$I_G = \frac{V_G}{R_S}$$

The steady state value of gate voltage is

$$V_{GS} = \frac{R_G V_G}{R_S + R_1 + R_G}$$

Where R_S is the internal resistance of gate drive force.

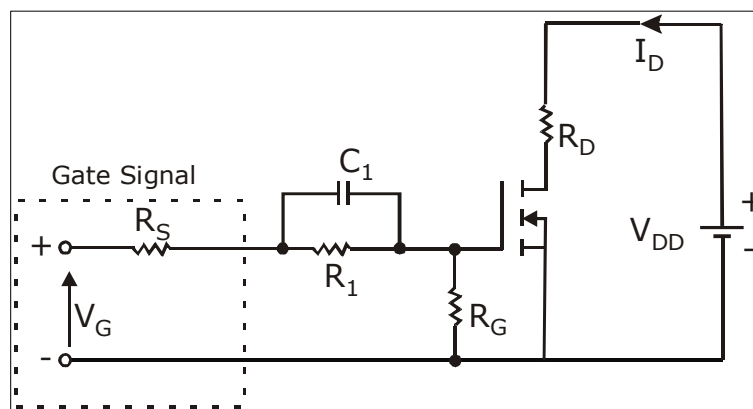

Fig.2.20: Fast turn on gate drive circuit 1

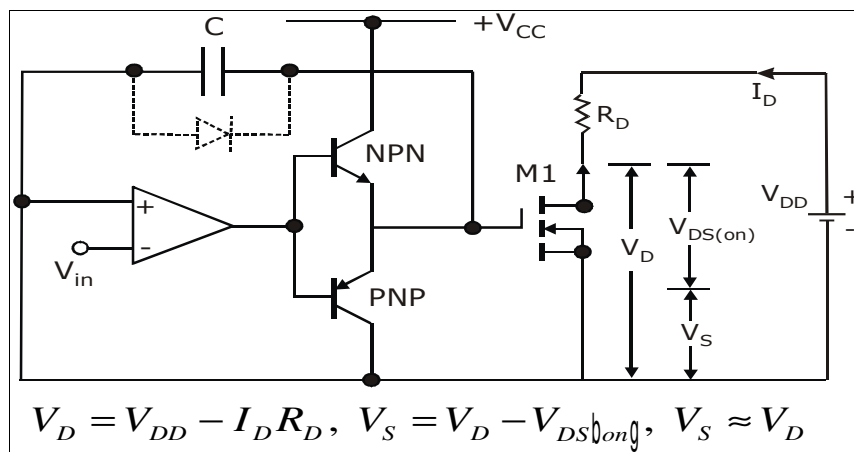

Fig.2.21: Fast turn on gate drive circuit 2

The above circuit is used in order to achieve switching speeds of the order of 100nsec or less. The above circuit as low output impedance and the ability to sink and source large currents. A totem poll arrangement that is capable of sourcing and sinking a large current is achieved by the PNP and NPN transistors. These transistors act as emitter followers and offer a low output impedance. These transistors operate in the linear region therefore minimize the

delay time. The gate signal of the power MOSFET may be generated by an op-amp. Let V_{in} be a negative voltage and initially assume that the MOSFET is off therefore the non-inverting terminal of the op-amp is at zero potential. The op-amp output is high therefore the NPN transistor is on and is a source of a large current since it is an emitter follower. This enables the gate-source capacitance C_{gs} to quickly charge upto the gate voltage required to turn-on the power MOSFET. Thus high speeds are achieved. When V_{in} becomes positive the output of op-amp becomes negative the PNP transistor turns-on and the gate-source capacitor quickly discharges through the PNP transistor. Thus the PNP transistor acts as a current sink and the MOSFET is quickly turned-off. The capacitor C helps in regulating the rate of rise and fall of the gate voltage thereby controlling the rate of rise and fall of MOSFET drain current. This can be explained as follows

- The drain-source voltage $V_{DS} = V_{DD} - I_D R_D$.
- If I_D increases V_{DS} reduces. Therefore the positive terminal of op-amp which is tied to the source terminal of the MOSFET feels this reduction and this reduction is transmitted to gate through the capacitor 'C' and the gate voltage reduces and the drain current is regulated by this reduction.

Comparison of MOSFET with BJT

- Power MOSFETS have lower switching losses but its on-resistance and conduction losses are more. A BJT has higher switching loss but lower conduction loss. So at high frequency applications power MOSFET is the obvious choice. But at lower operating frequencies BJT is superior.
- MOSFET has positive temperature coefficient for resistance. This makes parallel operation of MOSFET's easy. If a MOSFET shares increased current initially, it heats up faster, its resistance increases and this increased resistance causes this current to shift to other devices in parallel. A BJT is a negative temperature coefficient, so current sharing resistors are necessary during parallel operation of BJT's.
- In MOSFET secondary breakdown does not occur because it has positive temperature coefficient. But BJT exhibits negative temperature coefficient which results in secondary breakdown.
- Power MOSFET's in higher voltage ratings have more conduction losses.
- Power MOSFET's have lower ratings compared to BJT's. Power MOSFET's → 500V to 140A, BJT → 1200V, 800A.

2.7 IGBT

The metal oxide semiconductor insulated gate transistor or IGBT combines the advantages of BJT's and MOSFET's. Therefore an IGBT has high input impedance like a MOSFET and low-on state power loss as in a BJT. Further IGBT is free from second breakdown problem present in BJT.

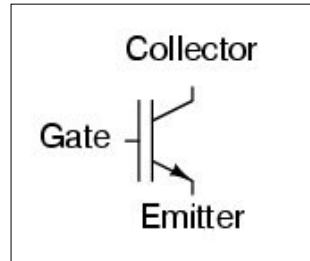

2.7.1 IGBT Basic Structure and Working

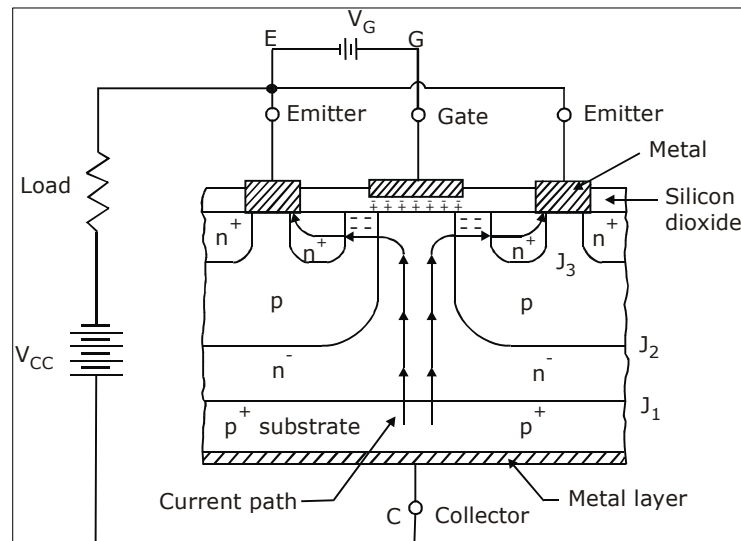

It is constructed virtually in the same manner as a power MOSFET. However, the substrate is now a p^+ layer called the collector.

When gate is positive with respect to emitter and with gate emitter voltage greater than V_{GTH} , an n channel is formed as in case of power MOSFET. This n^- channel short circuits the n^- region with n^+ emitter regions.

An electron movement in the n^- channel in turn causes substantial hole injection from p^+ substrate layer into the epitaxially n^- layer. Eventually a forward current is established.

The three layers p^+ , n^- and p constitute a pnp transistor with p^+ as emitter, n^- as base and p as collector. Also n^- , p and n^+ layers constitute a npn transistor. The MOSFET is formed

with input gate, emitter as source and n^- region as drain. Equivalent circuit is as shown below.

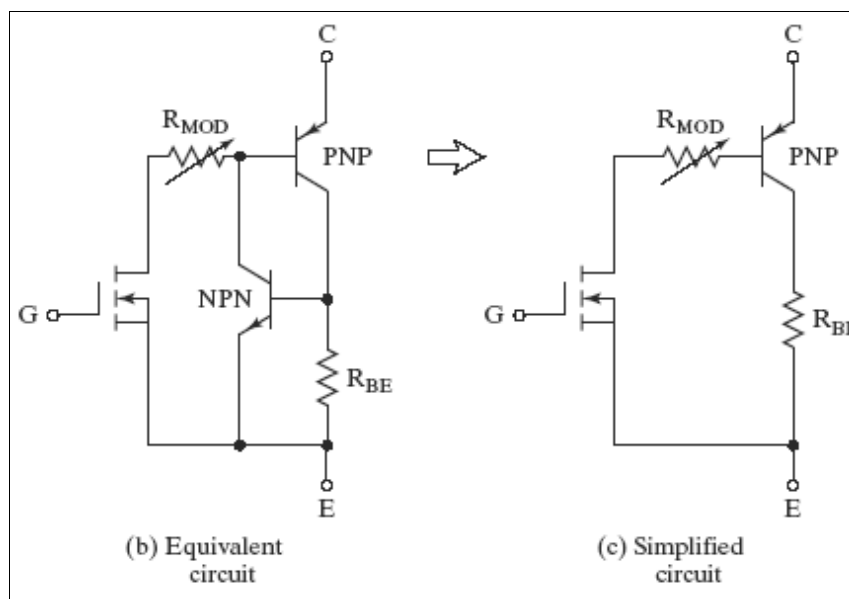
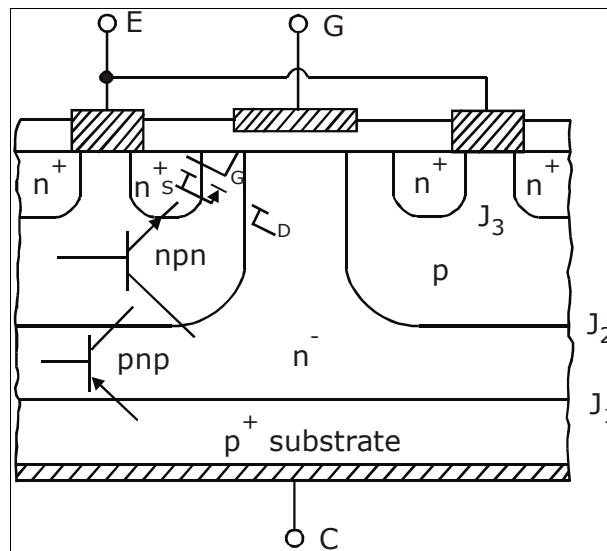

Also p serves as collector for pnp device and also as base for npn transistor. The two pnp and npn is formed as shown.

When gate is applied ($V_{GS} > V_{Gsth}$) MOSFET turns on. This gives the base drive to T_1 . Therefore T_1 starts conducting. The collector of T_1 is base of T_2 . Therefore regenerative action takes place and large number of carriers are injected into the n^- drift region. This reduces the ON-state loss of IGBT just like BJT.

When gate drive is removed IGBT is turn-off. When gate is removed the induced channel will vanish and internal MOSFET will turn-off. Therefore T_1 will turn-off if T_2 turns off.

Structure of IGBT is such that R_1 is very small. If R_1 small T_1 will not conduct therefore IGBT's are different from MOSFET's since resistance of drift region reduces when gate drive is applied due to p^+ injecting region. Therefore ON state IGBT is very small.

2.7.2 Static Characteristics

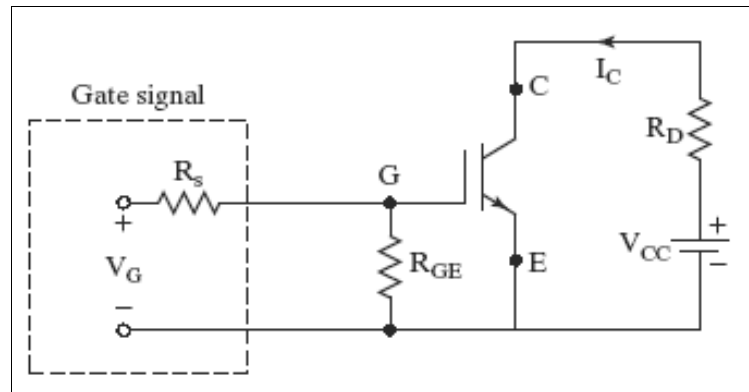

Fig.2.22: IGBT bias circuit

Static V-I characteristics (I_C versus V_{CE})

Same as in BJT except control is by V_{GE} . Therefore IGBT is a voltage controlled device.

Transfer Characteristics (I_C versus V_{GE})

Identical to that of MOSFET. When $V_{GE} < V_{GET}$, IGBT is in off-state.

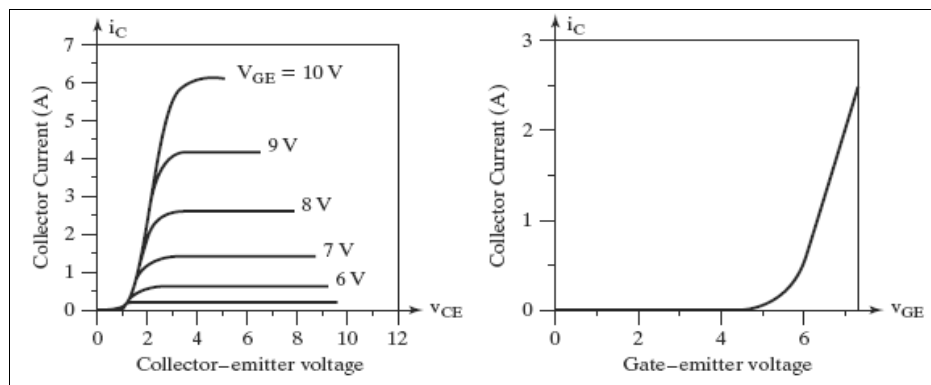

Applications

Widely used in medium power applications such as DC and AC motor drives, UPS systems, Power supplies for solenoids, relays and contractors.

Though IGBT's are more expensive than BJT's, they have lower gate drive requirements, lower switching losses. The ratings up to 1200V, 500A.

2.8 di/dt and dv/dt Limitations

Transistors require certain turn-on and turn-off times. Neglecting the delay time t_d and the storage time t_s , the typical voltage and current waveforms of a BJT switch is shown below.

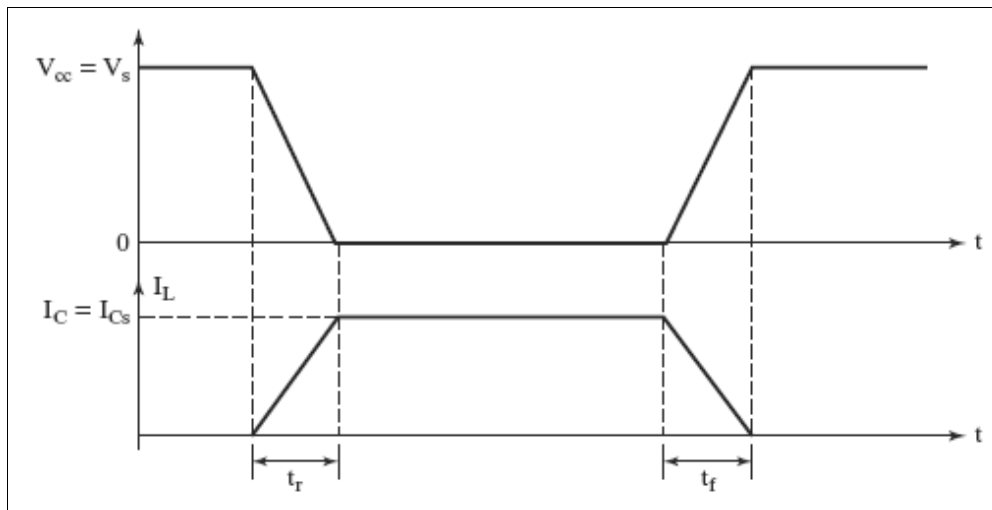

During turn-on, the collector rise and the di/dt is

$$\frac{di}{dt} = \frac{I_L}{t_r} = \frac{I_{cs}}{t_r} \quad \dots(1)$$

During turn off, the collector emitter voltage must rise in relation to the fall of the collector current, and is

$$\frac{dv}{dt} = \frac{V_s}{t_f} = \frac{V_{cc}}{t_f} \quad \dots(2)$$

The conditions di/dt and dv/dt in equation (1) and (2) are set by the transistor switching characteristics and must be satisfied during turn on and turn off. Protection circuits are normally required to keep the operating di/dt and dv/dt within the allowable limits of transistor. A typical switch with di/dt and dv/dt protection is shown in figure (a), with operating wave forms in figure (b). The RC network across the transistor is known as the snubber circuit or snubber and limits the dv/dt . The inductor L_s , which limits the di/dt , is sometimes called series snubber.

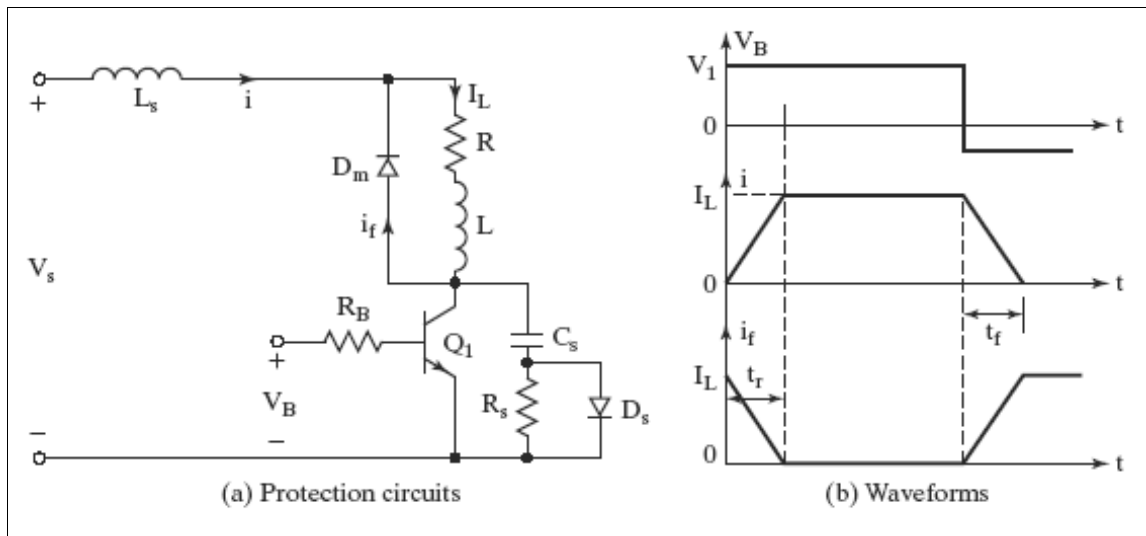

Let us assume that under steady state conditions the load current I_L is freewheeling through diode D_m , which has negligible reverse recovery time. When transistor Q_1 is turned on, the collector current rises and current of diode D_m falls, because D_m will behave as short circuited. The equivalent circuit during turn on is shown in figure below

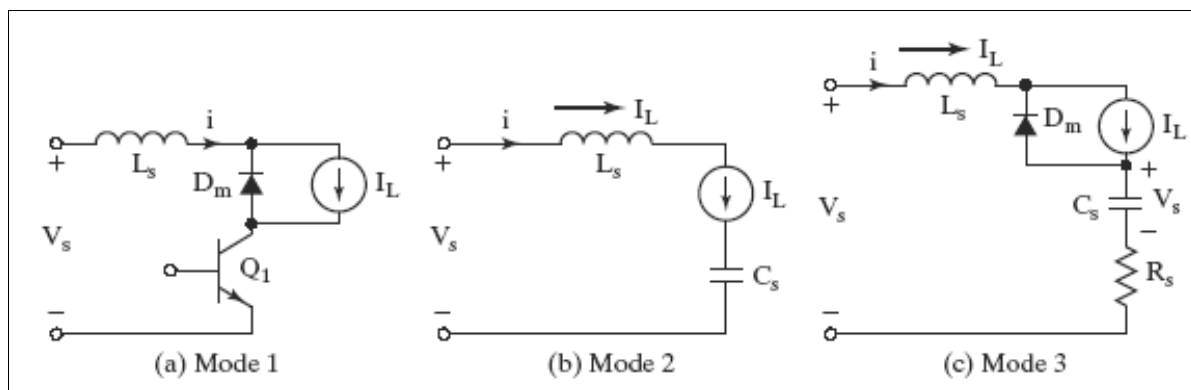

The turn on di/dt is

$$\frac{di}{dt} = \frac{V_s}{L_s} \quad \dots(3)$$

Equating equations (1) and (3) gives the value of L_s

$$L_s = \frac{V_s t_r}{I_L} \quad \dots(4)$$

During turn off, the capacitor C_s will charge by the load current and the equivalent circuit is shown in figure. The capacitor voltage will appear across the transistor and the dv/dt is

$$\frac{dv}{dt} = \frac{I_L}{C_s} \quad \dots(5)$$

Equating equation (2) to equation (5) gives the required value of capacitance,

$$C_s = \frac{I_L t_f}{V_s} \quad \dots(6)$$

Once the capacitor is charge to V_s , the freewheeling diode will turn on. Due to the energy stored in L_s , there will be damped resonant circuit as shown in figure . The RLC circuit is normally made critically damped to avoid oscillations. For unity critical damping, $\delta = 1$, and equation $\delta = \frac{\alpha}{\omega_0} = \frac{R}{2} \sqrt{\frac{C}{L}}$ yields

$$R_s = 2 \sqrt{\frac{L_s}{C_s}}$$

The capacitor C_s has to discharge through the transistor and the increase the peak current rating of the transistor. The discharge through the transistor can be avoided by placing resistor R_s across C_s instead of placing R_s across D_s .

The discharge current is shown in figure below. When choosing the value of R_s , the discharge time, $R_s C_s = \tau_s$ should also be considered. A discharge time of one third the switching period, T_s is usually adequate.

$$3R_s C_s = T_s = \frac{1}{f_s}$$

$$R_s = \frac{1}{3f_s C_s}$$

2.9 Isolation of Gate and Base Drives

Necessity

Driver circuits are operated at very low power levels. Normally the gating circuit are digital in nature which means the signal levels are 3 to 12 volts. The gate and base drives are connected to power devices which operate at high power levels.

Illustration

The logic circuit generates four pulses; these pulses have common terminals. The terminal g , which has a voltage of V_G , with respect to terminal C , cannot be connected directly to gate terminal G , therefore V_{g1} should be applied between G_1 & S_1 of transistor Q_1 . Therefore there is need for isolation between logic circuit and power transistor.

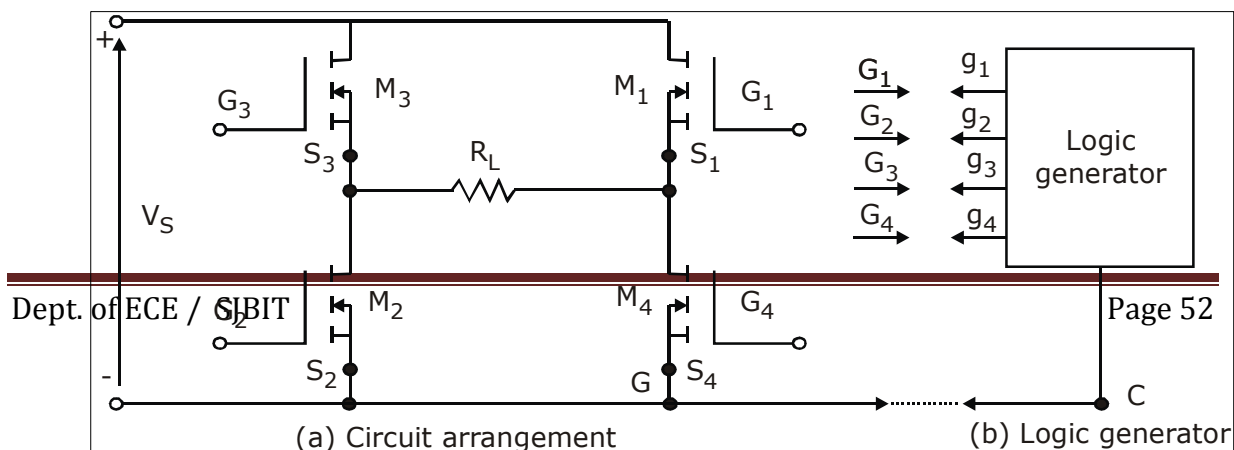

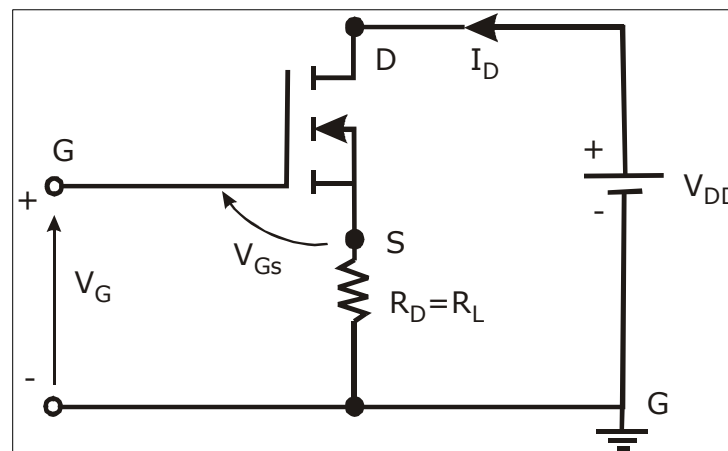
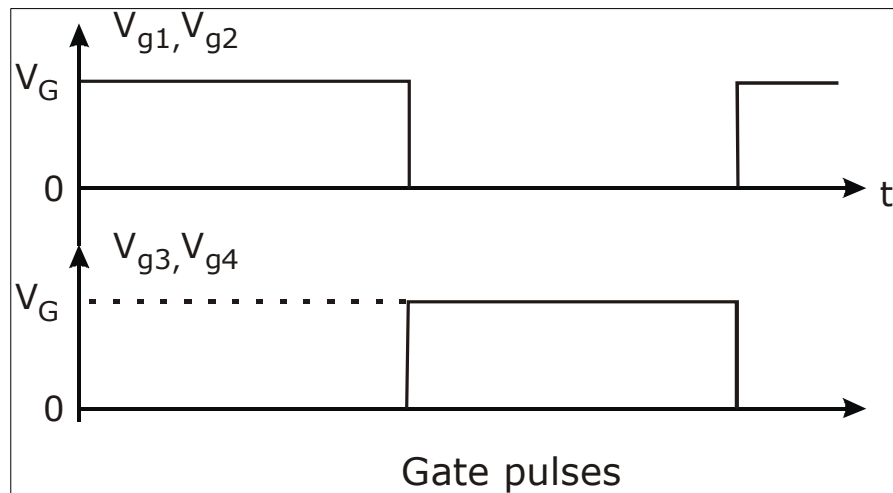

$$V_{GS} = V_G - I_D R_D$$

There are two ways of floating or isolating control or gate signal with respect to ground.

- Pulse transformers
- Optocouplers

Pulse Transformers

Pulse transformers have one primary winding and can have one or more secondary windings.

Multiple secondary windings allow simultaneous gating signals to series and parallel connected transistors. The transformer should have a very small leakage inductance and the rise time of output should be very small.

The transformer would saturate at low switching frequency and output would be distorted.

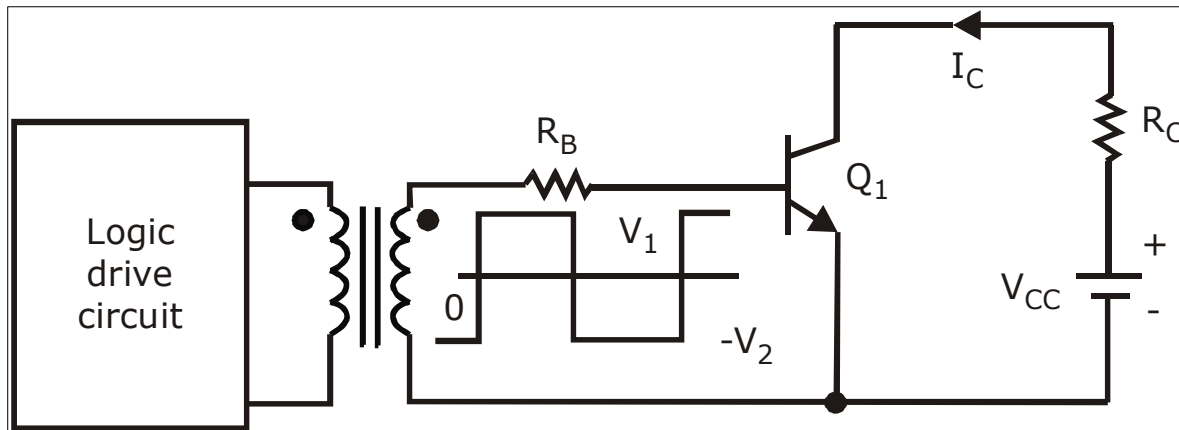

Optocouplers

Optocouplers combine infrared LED and a silicon photo transistor. The input signal is applied to ILED and the output is taken from the photo transistor. The rise and fall times of photo transistor are very small with typical values of turn on time = $2.5\mu s$ and turn off of 300ns. This limits the high frequency applications. The photo transistor could be a darlington pair. The phototransistor requires separate power supply and adds to complexity and cost and weight of driver circuits.

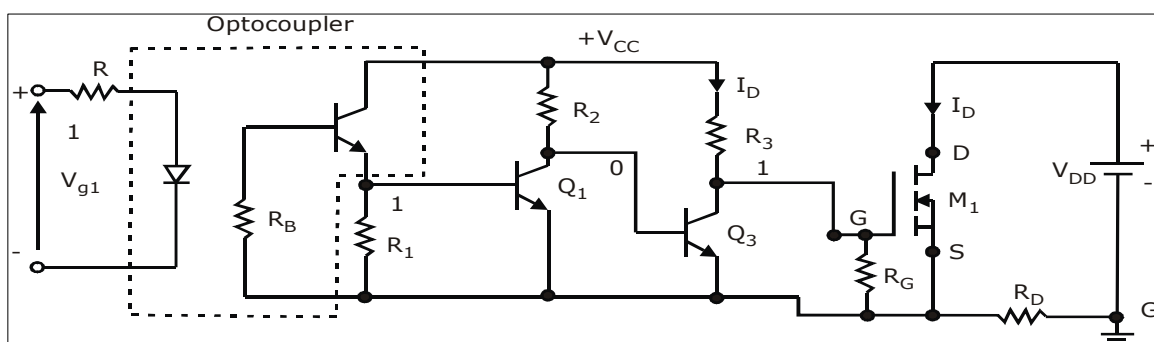

Recommended questions:

1. Explain the control characteristics of the following semiconductor devices
 - 1) Power BJT 3) MOSFET 4) IGBT
2. Give the comparison between MOSFET and BJT.
3. Draw the circuit symbol of IGBT. Compare its advantages over MOSFET

4. Draw the switching model and switching waveforms of a power MOSFET, define the various switching applications.
5. With a circuit diagram and waveforms of base circuit voltage, base current and collector current under saturation for a power transistor, show the delay that occurs during the turn-ON and turn – OFF.
6. Explain the terms Overdrive factor (ODF) and forced beta for a power transistor for switching applications?
7. Explain the switching characteristics of BJT.
8. Explain the steady and switching characteristics of MOSFET.

UNIT-3

THYRISTORS

A thyristor is the most important type of power semiconductor devices. They are extensively used in power electronic circuits. They are operated as bi-stable switches from non-conducting to conducting state.

A thyristor is a four layer, semiconductor of p-n-p-n structure with three p-n junctions. It has three terminals, the anode, cathode and the gate.

The word thyristor is coined from thyatron and transistor. It was invented in the year 1957 at Bell Labs. The Different types of Thyristors are

- Silicon Controlled Rectifier (SCR).
- TRIAC
- DIAC
- Gate Turn Off Thyristor (GTO)

3.1 Silicon Controlled Rectifier (SCR)

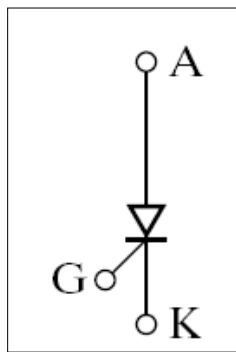

The SCR is a four layer three terminal device with junctions J_1, J_2, J_3 as shown. The construction of SCR shows that the gate terminal is kept nearer the cathode. The approximate thickness of each layer and doping densities are as indicated in the figure. In terms of their lateral dimensions Thyristors are the largest semiconductor devices made. A complete silicon wafer as large as ten centimeter in diameter may be used to make a single high power thyristor.

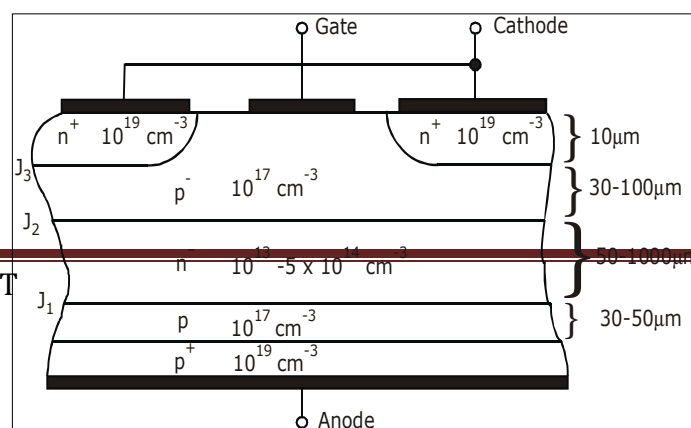

Fig.3.1: Structure of a generic thyristor

Qualitative Analysis

When the anode is made positive with respect the cathode junctions J_1 & J_3 are forward biased and junction J_2 is reverse biased. With anode to cathode voltage V_{AK} being small, only leakage current flows through the device. The SCR is then said to be in the forward blocking state. If V_{AK} is further increased to a large value, the reverse biased junction J_2 will breakdown due to avalanche effect resulting in a large current through the device. The voltage at which this phenomenon occurs is called the forward breakdown voltage V_{BO} . Since the other junctions J_1 & J_3 are already forward biased, there will be free movement of carriers across all three junctions resulting in a large forward anode current. Once the SCR is switched on, the voltage drop across it is very small, typically 1 to 1.5V. The anode current is limited only by the external impedance present in the circuit.

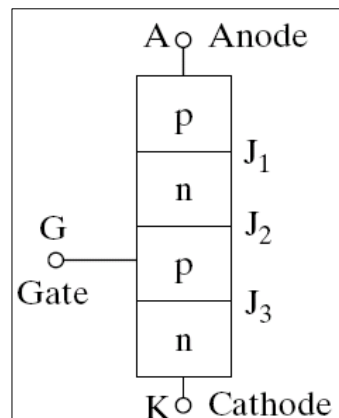

Fig.3.2: Simplified model of a thyristor

Although an SCR can be turned on by increasing the forward voltage beyond V_{BO} , in practice, the forward voltage is maintained well below V_{BO} and the SCR is turned on by applying a positive voltage between gate and cathode. With the application of positive gate voltage, the leakage current through the junction J_2 is increased. This is because the resulting gate current consists mainly of electron flow from cathode to gate. Since the bottom end layer is heavily doped as compared to the p-layer, due to the applied voltage, some of these electrons

reach junction J_2 and add to the minority carrier concentration in the p-layer. This raises the reverse leakage current and results in breakdown of junction J_2 even though the applied forward voltage is less than the breakdown voltage V_{BO} . With increase in gate current breakdown occurs earlier.

V-I Characteristics

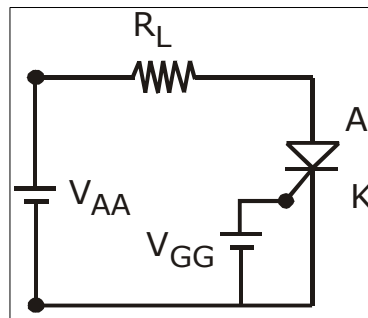

Fig.3.3 Circuit

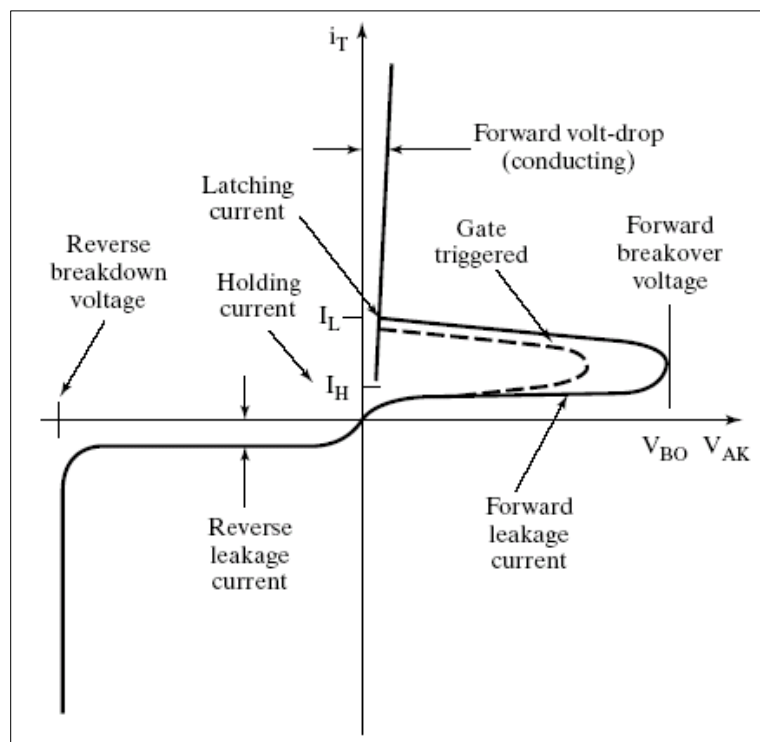

Fig 3.4: V-I Characteristics

A typical V-I characteristics of a thyristor is shown above. In the reverse direction the thyristor appears similar to a reverse biased diode which conducts very little current until avalanche breakdown occurs. In the forward direction the thyristor has two stable states or modes of operation that are connected together by an unstable mode that appears as a negative resistance on the V-I characteristics. The low current high voltage region is the forward blocking state or the off state and the low voltage high current mode is the on state.

For the forward blocking state the quantity of interest is the forward blocking voltage V_{BO} which is defined for zero gate current. If a positive gate current is applied to a thyristor then the transition or break over to the on state will occur at smaller values of anode to cathode voltage as shown. Although not indicated the gate current does not have to be a dc current but instead can be a pulse of current having some minimum time duration. This ability to switch the thyristor by means of a current pulse is the reason for wide spread applications of the device.

However once the thyristor is in the on state the gate cannot be used to turn the device off. The only way to turn off the thyristor is for the external circuit to force the current through the device to be less than the holding current for a minimum specified time period.

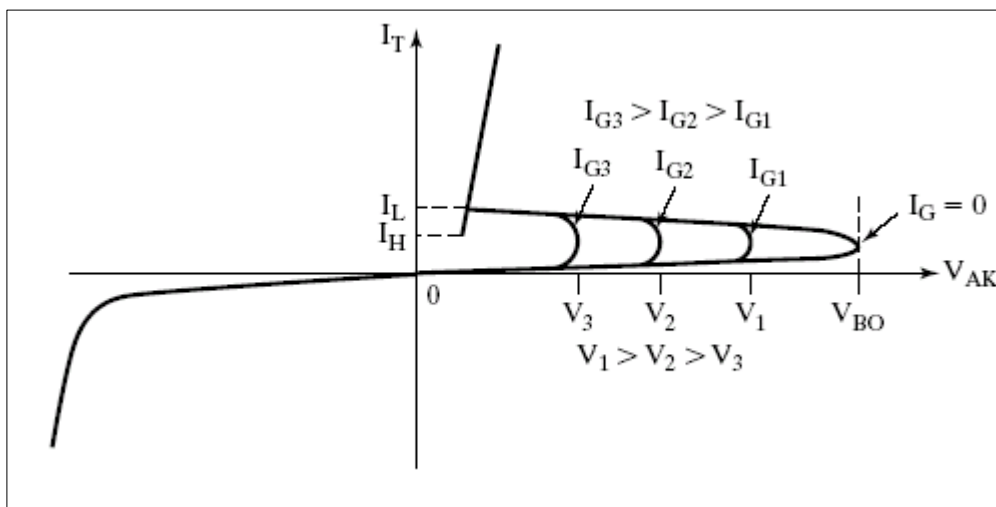

Fig.3.5: Effects on gate current on forward blocking voltage

Holding Current I_H

After an SCR has been switched to the on state a certain minimum value of anode current is required to maintain the thyristor in this low impedance state. If the anode current is reduced below the critical holding current value, the thyristor cannot maintain the current through it and reverts to its off state usually I_{μ} is associated with turn off the device.

Latching Current I_L

After the SCR has switched on, there is a minimum current required to sustain conduction. This current is called the latching current. I_L associated with turn on and is usually greater than holding current.

3.2 Thyristor Gate Characteristics

Fig. 3.6 shows the gate trigger characteristics.

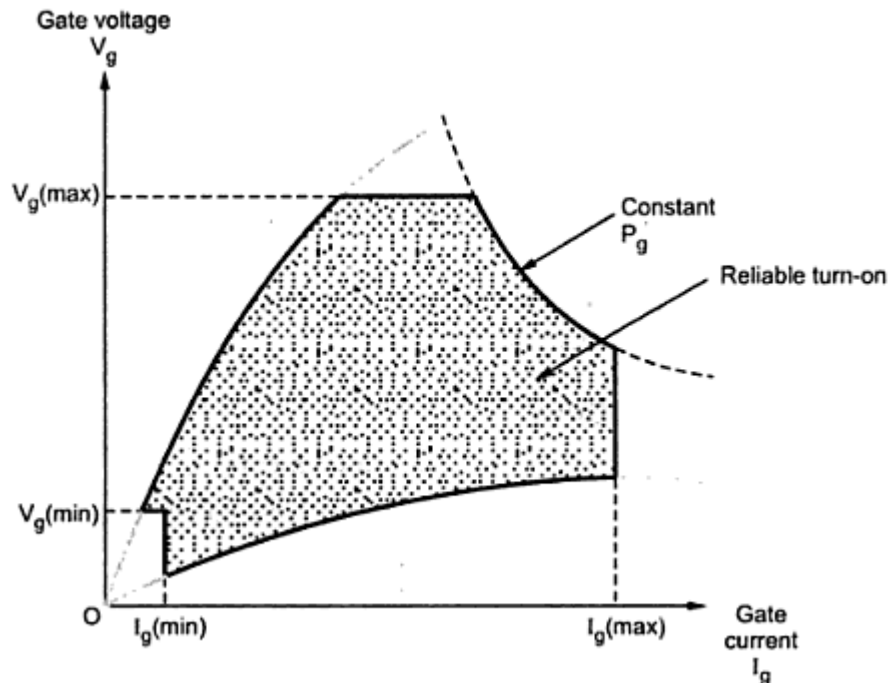

Fig 3.6 Gate Characteristics

The gate voltage is plotted with respect to gate current in the above characteristics. $I_{g(max)}$ is the maximum gate current that can flow through the thyristor without damaging it. Similarly $V_{g(max)}$ is the maximum gate voltage to be applied. Similarly $V_{g(min)}$ and $I_{g(min)}$ are minimum gate voltage and current, below which thyristor will not be turned-on. Hence to turn-on the thyristor successfully the gate current and voltage should be

$$I_{g(min)} < I_g < I_{g(max)}$$

$$V_{g(min)} < V_g < V_{g(max)}$$

The characteristic of Fig. 3.6 also shows the curve for constant gate power (P_g). Thus for reliable turn-on, the (V_g, I_g) point must lie in the shaded area in Fig. 3.6. It turns-on thyristor successfully. Note that any spurious voltage/current spikes at the gate must be less than $V_{g(min)}$ and $I_{g(min)}$ to avoid false triggering of the thyristor. The gate characteristics shown in Fig. 3.6 are for DC values of gate voltage and current.

3.2.1 Pulsed Gate Drive

Instead of applying a continuous (DC) gate drive, the pulsed gate drive is used. The gate voltage and current are applied in the form of high frequency pulses. The frequency of these

pulses is upto 10 kHz. Hence the width of the pulse can be upto 100 micro seconds. The pulsed gate drive is applied for following reasons (advantages):

- i) The thyristor has small turn-on time i.e. upto 5 microseconds. Hence a pulse of gate drive is sufficient to turn-on the thyristor.
- ii) Once thyristor turns-on, there is no need of gate drive. Hence gate drive in the form of pulses is suitable.
- iii) The DC gate voltage and current increases losses in the thyristor. Pulsed gate drive has reduced losses.
- iv) The pulsed gate drive can be easily passed through isolation transformers to isolate thyristor and trigger circuit.

3.2.2 Requirement of Gate Drive

The gate drive has to satisfy the following requirements:

- i) The maximum gate power should not be exceeded by gate drive, otherwise thyristor will be damaged.
- ii) The gate voltage and current should be within the limits specified by gate characteristics (Fig. 3.6) for successful turn-on.
- iii) The gate drive should be preferably pulsed. In case of pulsed drive the following relation must be satisfied: (Maximum gate power x pulse width) x (Pulse frequency) \leq Allowable average gate power
- iv) The width of the pulse should be sufficient to turn-on the thyristor successfully.
- v) The gate drive should be isolated electrically from the thyristor. This avoids any damage to the trigger circuit if in case thyristor is damaged.
- vi) The gate drive should not exceed permissible negative gate to cathode voltage, otherwise the thyristor is damaged.
- vii) The gate drive circuit should not sink current out of the thyristor after turn-on.

3.3 Quantitative Analysis

Two Transistor Model

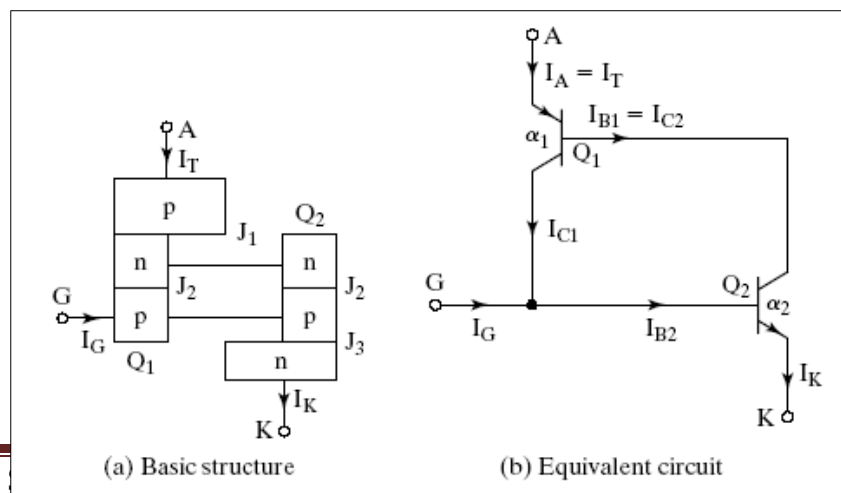

The general transistor equations are,

$$I_C = \beta I_B + (1 + \beta) I_{CBO}$$

$$I_C = \alpha I_E + I_{CBO}$$

$$I_E = I_C + I_B$$

$$I_B = I_E (1 - \alpha) - I_{CBO}$$

The SCR can be considered to be made up of two transistors as shown in above figure.

Considering PNP transistor of the equivalent circuit,

$$\begin{aligned} I_{E_1} &= I_A, I_C = I_{C_1}, \alpha = \alpha_1, I_{CBO} = I_{CBO_1}, I_B = I_{B_1} \\ \therefore I_{B_1} &= I_A (1 - \alpha_1) - I_{CBO_1} \quad \text{--- (1)} \end{aligned}$$

Considering NPN transistor of the equivalent circuit,

$$\begin{aligned} I_C &= I_{C_2}, I_B = I_{B_2}, I_{E_2} = I_K = I_A + I_G \\ I_{C_2} &= \alpha_2 I_k + I_{CBO_2} \\ I_{C_2} &= \alpha_2 (I_A + I_G) + I_{CBO_2} \quad \text{--- (2)} \end{aligned}$$

From the equivalent circuit, we see that

$$\begin{aligned} \therefore I_{C_2} &= I_{B_1} \\ \Rightarrow I_A &= \frac{\alpha_2 I_g + I_{CBO_1} + I_{CBO_2}}{1 - (\alpha_1 + \alpha_2)} \end{aligned}$$

Two transistors analog is valid only till SCR reaches ON state

Case 1: When $I_g = 0$,

$$I_A = \frac{I_{CBO_1} + I_{CBO_2}}{1 - (\alpha_1 + \alpha_2)}$$

The gain α_1 of transistor T_1 varies with its emitter current $I_E = I_A$. Similarly varies with $I_E = I_A + I_g = I_K$. In this case, with $I_g = 0$, α_2 varies only with I_A . Initially when the applied forward voltage is small, $(\alpha_1 + \alpha_2) < 1$.

If however the reverse leakage current is increased by increasing the applied forward voltage, the gains of the transistor increase, resulting in $(\alpha_1 + \alpha_2) \rightarrow 1$.

From the equation, it is seen that when $(\alpha_1 + \alpha_2) = 1$, the anode current I_A tends towards ∞ . This explains the increase in anode current for the break over voltage V_{B0} .

Case 2: With gate current I_g applied.

When sufficient gate drive is applied, we see that $I_{B_2} = I_g$ is established. This in turn results in a current through transistor T_2 , these increases α_2 of T_2 . But with the existence of $I_{C_2} = \beta_2 I_{B_2} = \beta_2 I_g$, a current through T_1 is established. Therefore, $I_{C_1} = \beta_1 I_{B_1} = \beta_1 \beta_2 I_{B_2} = \beta_1 \beta_2 I_g$. This current in turn is connected to the base of T_2 . Thus the base drive of T_2 is increased which in turn increases the base drive of T_1 , therefore regenerative feedback or positive feedback is established between the two transistors. This causes $(\alpha_1 + \alpha_2)$ to tend to unity therefore the anode current begins to grow towards a large value. This regeneration continues even if I_g is removed this characteristic of SCR makes it suitable for pulse triggering; SCR is also called a Latching Device.

3.4 Switching Characteristics (Dynamic characteristics)

Thyristor Turn-ON Characteristics

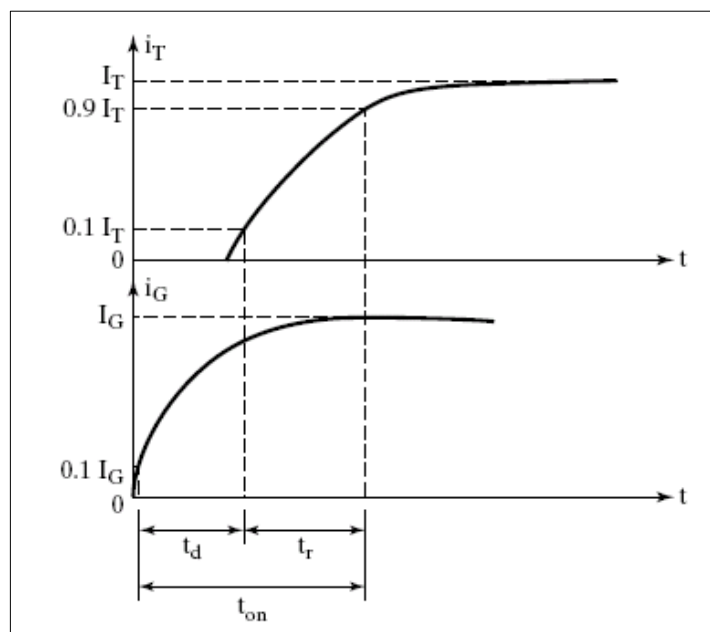
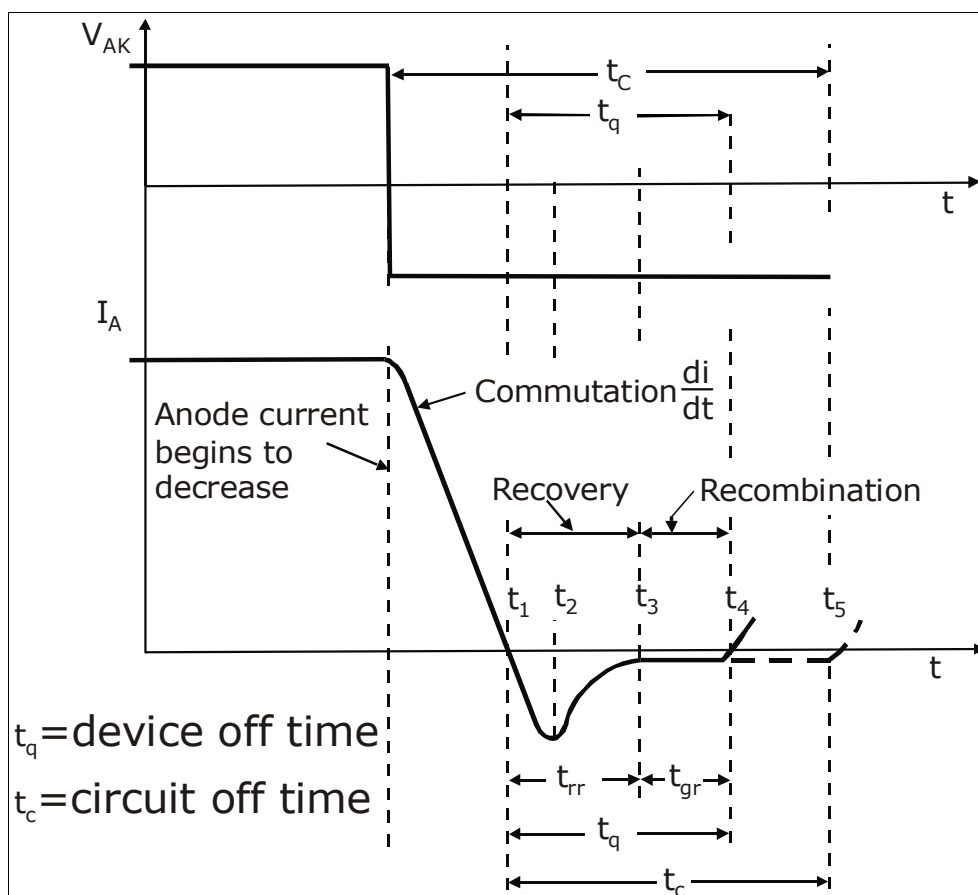

Fig.3.7: Turn-on characteristics

When the SCR is turned on with the application of the gate signal, the SCR does not conduct fully at the instant of application of the gate trigger pulse. In the beginning, there is no appreciable increase in the SCR anode current, which is because, only a small portion of the silicon pellet in the immediate vicinity of the gate electrode starts conducting. The duration between 90% of the peak gate trigger pulse and the instant the forward voltage has fallen to 90% of its initial value is called the gate controlled / trigger delay time t_{gd} . It is also defined as the duration between 90% of the gate trigger pulse and the instant at which the anode current rises to 10% of its peak value. t_{gd} is usually in the range of 1µsec.

Once t_{gd} has lapsed, the current starts rising towards the peak value. The period during which the anode current rises from 10% to 90% of its peak value is called the rise time. It is also defined as the time for which the anode voltage falls from 90% to 10% of its peak value. The summation of t_{gd} and t_r gives the turn on time t_{on} of the thyristor.

Thyristor Turn OFF Characteristics



When an SCR is turned on by the gate signal, the gate loses control over the device and the device can be brought back to the blocking state only by reducing the forward current to a level below that of the holding current. In AC circuits, however, the current goes through a

natural zero value and the device will automatically switch off. But in DC circuits, where no neutral zero value of current exists, the forward current is reduced by applying a reverse voltage across anode and cathode and thus forcing the current through the SCR to zero.

As in the case of diodes, the SCR has a reverse recovery time t_{rr} which is due to charge storage in the junctions of the SCR. These excess carriers take some time for recombination resulting in the gate recovery time or reverse recombination time t_{gr} . Thus, the turn-off time t_q is the sum of the durations for which reverse recovery current flows after the application of reverse voltage and the time required for the recombination of all excess carriers present. At the end of the turn off time, a depletion layer develops across J_2 and the junction can now withstand the forward voltage. The turn off time is dependent on the anode current, the magnitude of reverse V_g applied and the magnitude and rate of application of the forward voltage. The turn off time for convertor grade SCR's is 50 to 100 μ sec and that for inverter grade SCR's is 10 to 20 μ sec.

To ensure that SCR has successfully turned off, it is required that the circuit off time t_c be greater than SCR turn off time t_q .

Thyristor Turn ON

- **Thermal Turn on:** If the temperature of the thyristor is high, there will be an increase in charge carriers which would increase the leakage current. This would cause an increase in α_1 & α_2 and the thyristor may turn on. This type of turn on may cause thermal run away and is usually avoided.
- **Light:** If light be allowed to fall on the junctions of a thyristor, charge carrier concentration would increase which may turn on the SCR.
- **LASCR:** Light activated SCRs are turned on by allowing light to strike the silicon wafer.
- **High Voltage Triggering:** This is triggering without application of gate voltage with only application of a large voltage across the anode-cathode such that it is greater than the forward breakdown voltage V_{BO} . This type of turn on is destructive and should be avoided.
- **Gate Triggering:** Gate triggering is the method practically employed to turn-on the thyristor. Gate triggering will be discussed in detail later.
- **$\frac{dv}{dt}$ Triggering:** Under transient conditions, the capacitances of the p-n junction will influence the characteristics of a thyristor. If the thyristor is in the blocking state, a rapidly rising voltage applied across the device would cause a high current to flow through the device resulting in turn-on. If i_{j_2} is the current through the junction j_2 and C_{j_2} is the junction capacitance and V_{j_2} is the voltage across j_2 , then

$$i_{j_2} = \frac{dq_2}{dt} = \frac{d}{dt}(C_{j_2} V_{j_2}) = C_{j_2} \frac{dV_{j_2}}{dt} + V_{j_2} \frac{dC_{j_2}}{dt}$$

From the above equation, we see that if $\frac{dv}{dt}$ is large, i_{j_2} will be large. A high value of charging current may damage the thyristor and the device must be protected against high $\frac{dv}{dt}$.

The manufacturers specify the allowable $\frac{dv}{dt}$.

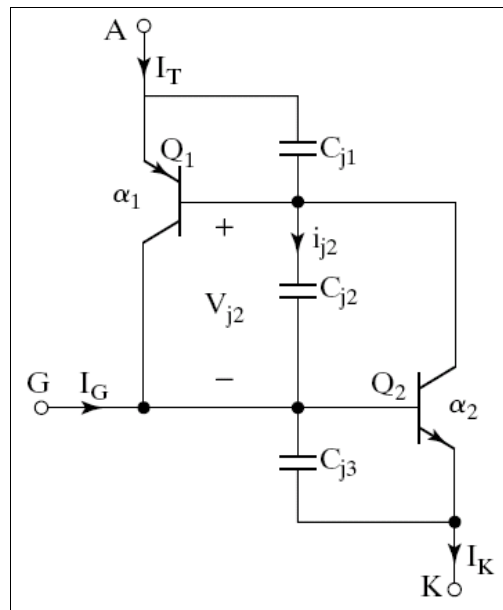

Thyristor Ratings

First Subscript	Second Subscript	Third Subscript
D → off state	W → working	M → Peak Value
T → ON state	R → Repetitive	
F → Forward	S → Surge or non-repetitive	
R → Reverse		

VOLTAGE RATINGS

V_{DWM} : This specifies the peak off state working forward voltage of the device. This specifies the maximum forward off state voltage which the thyristor can withstand during its working.

V_{DRM} : This is the peak repetitive off state forward voltage that the thyristor can block repeatedly in the forward direction (transient).

V_{DSM} : This is the peak off state surge / non-repetitive forward voltage that will occur across the thyristor.

V_{RWM} : This the peak reverse working voltage that the thyristor can withstand in the reverse direction.

V_{RRM} : It is the peak repetitive reverse voltage. It is defined as the maximum permissible instantaneous value of repetitive applied reverse voltage that the thyristor can block in reverse direction.

V_{RSM} : Peak surge reverse voltage. This rating occurs for transient conditions for a specified time duration.

V_T : On state voltage drop and is dependent on junction temperature.

V_{TM} : Peak on state voltage. This is specified for a particular anode current and junction temperature.

$\frac{dv}{dt}$ rating: This is the maximum rate of rise of anode voltage that the SCR has to withstand

and which will not trigger the device without gate signal (refer $\frac{dv}{dt}$ triggering).

Current Rating

$I_{Taverage}$: This is the on state average current which is specified at a particular temperature.

I_{TRMS} : This is the on-state RMS current.

Latching current, I_L : After the SCR has switched on, there is a minimum current required to sustain conduction. This current is called the latching current. I_L associated with turn on and is usually greater than holding current

Holding current, I_H : After an SCR has been switched to the on state a certain minimum value of anode current is required to maintain the thyristor in this low impedance state. If the anode current is reduced below the critical holding current value, the thyristor cannot maintain the current through it and reverts to its off state usually I_H is associated with turn off the device.

$\frac{di}{dt}$ rating: This is a non repetitive rate of rise of on-state current. This maximum value of rate of rise of current is which the thyristor can withstand without destruction. When thyristor is switched on, conduction starts at a place near the gate. This small area of conduction spreads rapidly and if rate of rise of anode current $\frac{di}{dt}$ is large compared to the spreading velocity of carriers, local hotspots will be formed near the gate due to high current density. This causes the junction temperature to rise above the safe limit and the SCR may be damaged permanently. The $\frac{di}{dt}$ rating is specified in $A/\mu\text{sec}$.

Gate Specifications

I_{GT} : This is the required gate current to trigger the SCR. This is usually specified as a DC value.

V_{GT} : This is the specified value of gate voltage to turn on the SCR (dc value).

V_{GD} : This is the value of gate voltage, to switch from off state to on state. A value below this will keep the SCR in off state.

Q_{RR} : Amount of charge carriers which have to be recovered during the turn off process.

R_{thjc} : Thermal resistance between junction and outer case of the device.

Gate Triggering Methods

Types

The different methods of gate triggering are the following

- R-triggering.
- RC triggering.
- UJT triggering.

3.5 Resistance Triggering

A simple resistance triggering circuit is as shown. The resistor R_1 limits the current through the gate of the SCR. R_2 is the variable resistance added to the circuit to achieve control over the triggering angle of SCR. Resistor ‘R’ is a stabilizing resistor. The diode D is required to ensure that no negative voltage reaches the gate of the SCR.

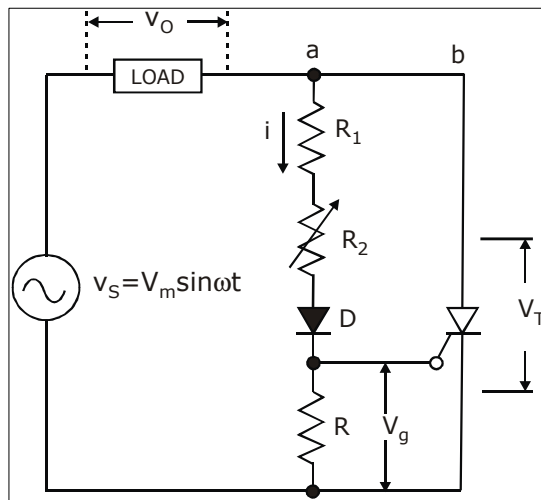

Fig.3.4: Resistance firing circuit

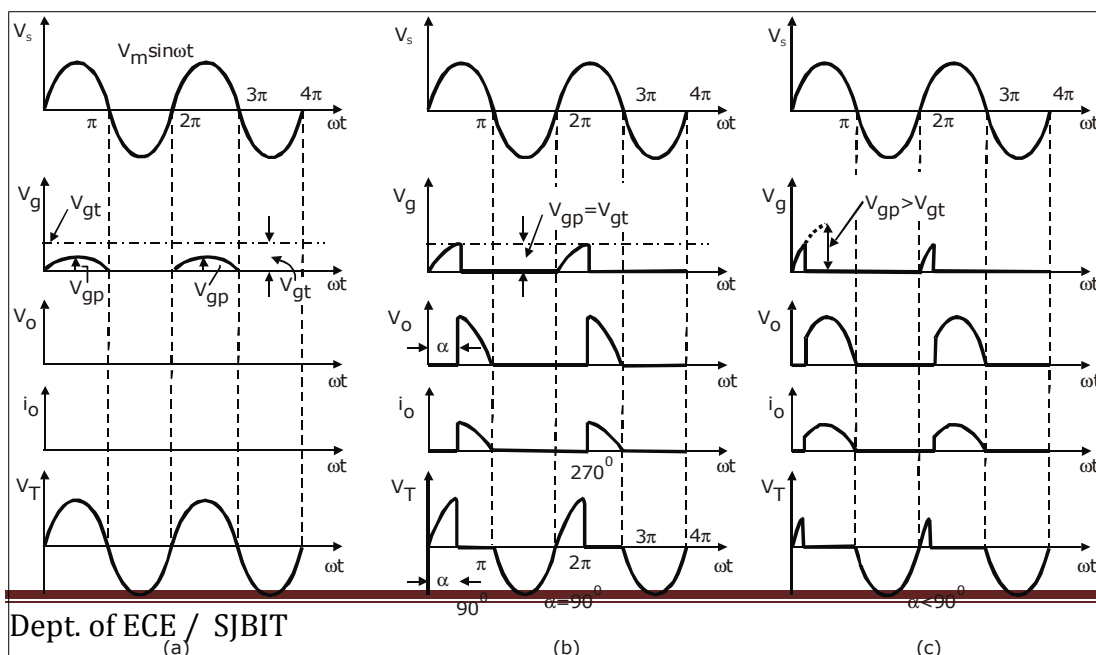

Fig.3.8: Resistance firing of an SCR in half wave circuit with dc load

(a) No triggering of SCR (b) $\alpha = 90^\circ$ (c) $\alpha < 90^\circ$ **Design**

With $R_2 = 0$, we need to ensure that $\frac{V_m}{R_1} < I_{gm}$, where I_{gm} is the maximum or peak gate current of the SCR. Therefore $R_1 \geq \frac{V_m}{I_{gm}}$.

Also with $R_2 = 0$, we need to ensure that the voltage drop across resistor 'R' does not exceed V_{gm} , the maximum gate voltage

$$\begin{aligned} V_{gm} &\geq \frac{V_m R}{R_1 + R} \\ \therefore V_{gm} R_1 + V_{gm} R &\geq V_m R \\ \therefore V_{gm} R_1 &\geq R(V_m - V_{gm}) \\ R &\leq \frac{V_{gm} R_1}{V_m - V_{gm}} \end{aligned}$$

Operation**Case 1:** $V_{gp} < V_{gt}$

V_{gp} , the peak gate voltage is less than V_{gt} since R_2 is very large. Therefore, current 'I' flowing through the gate is very small. SCR will not turn on and therefore the load voltage is zero and v_{scr} is equal to V_s . This is because we are using only a resistive network. Therefore, output will be in phase with input.

Case 2: $V_{gp} = V_{gt}$, $R_2 \rightarrow$ optimum value.

When R_2 is set to an optimum value such that $V_{gp} = V_{gt}$, we see that the SCR is triggered at 90° (since V_{gp} reaches its peak at 90° only). The waveforms show that the load voltage is zero till 90° and the voltage across the SCR is the same as input voltage till it is triggered at 90° .

Case 3: $V_{gp} > V_{gt}$, $R_2 \rightarrow$ small value.

The triggering value V_{gt} is reached much earlier than 90° . Hence the SCR turns on earlier than V_s reaches its peak value. The waveforms as shown with respect to $V_s = V_m \sin \omega t$.

At $\omega t = \alpha, V_s = V_{gt}, V_m = V_{gp} (\because V_{gt} = V_{gp} \sin \alpha)$

Therefore $\alpha = \sin^{-1} \left(\frac{V_{gt}}{V_{gp}} \right)$

But $V_{gp} = \frac{V_m R}{R_1 + R_2 + R}$

Therefore $\alpha = \sin^{-1} \left[\frac{V_{gt} (R_1 + R_2 + R)}{V_m R} \right]$

Since V_{gt}, R_1, R are constants

3.6 Resistance Capacitance Triggering

A. RC Half Wave

Capacitor 'C' in the circuit is connected to shift the phase of the gate voltage. D_1 is used to prevent negative voltage from reaching the gate cathode of SCR.

In the negative half cycle, the capacitor charges to the peak negative voltage of the supply ($-V_m$) through the diode D_2 . The capacitor maintains this voltage across it, till the supply voltage crosses zero. As the supply becomes positive, the capacitor charges through resistor 'R' from initial voltage of $-V_m$, to a positive value.

When the capacitor voltage is equal to the gate trigger voltage of the SCR, the SCR is fired and the capacitor voltage is clamped to a small positive value.

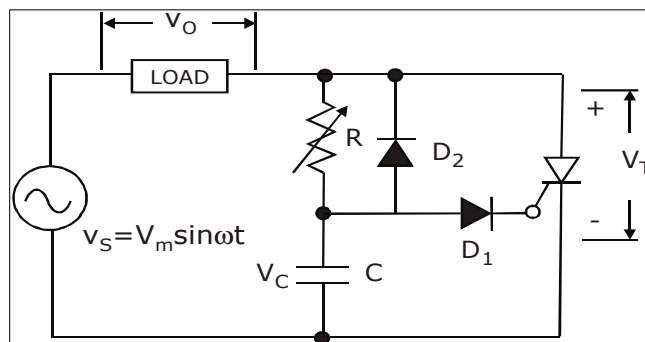

Fig.: RC half-wave trigger circuit

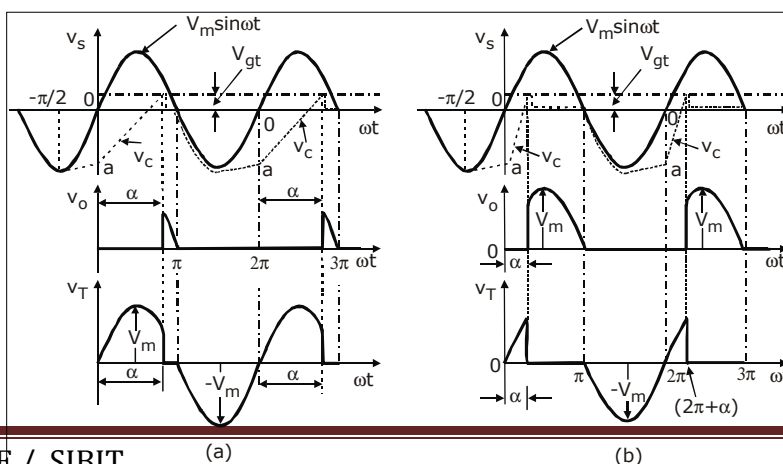

Fig.3.9: Waveforms for RC half-wave trigger circuit

(a) High value of R (b) Low value of R

Case 1: R → Large.

When the resistor ‘R’ is large, the time taken for the capacitance to charge from $-V_m$ to V_{gt} is large, resulting in larger firing angle and lower load voltage.

Case 2: R → Small

When ‘R’ is set to a smaller value, the capacitor charges at a faster rate towards V_{gt} resulting in early triggering of SCR and hence V_L is more. When the SCR triggers, the voltage drop across it falls to 1 – 1.5V. This in turn lowers, the voltage across R & C. Low voltage across the SCR during conduction period keeps the capacitor discharge during the positive half cycle.

Design Equation

From the circuit $V_C = V_{gt} + V_{d1}$. Considering the source voltage and the gate circuit, we can write $v_s = I_{gt}R + V_C$. SCR fires when $v_s \geq I_{gt}R + V_C$ that is $v_s \geq I_{gt}R + V_{gt} + V_{d1}$. Therefore $R \leq \frac{v_s - V_{gt} - V_{d1}}{I_{gt}}$. The RC time constant for zero output voltage that is maximum firing angle

for power frequencies is empirically gives as $RC \geq 1.3 \left(\frac{T}{2} \right)$.

B. RC Full Wave

A simple circuit giving full wave output is shown in figure below. In this circuit the initial voltage from which the capacitor ‘C’ charges is essentially zero. The capacitor ‘C’ is reset to this voltage by the clamping action of the thyristor gate. For this reason the charging time constant RC must be chosen longer than for half wave RC circuit in order to delay the triggering. The RC value is empirically chosen as $RC \geq \frac{50T}{2}$. Also $R \leq \frac{v_s - V_{gt}}{I_{gt}}$.

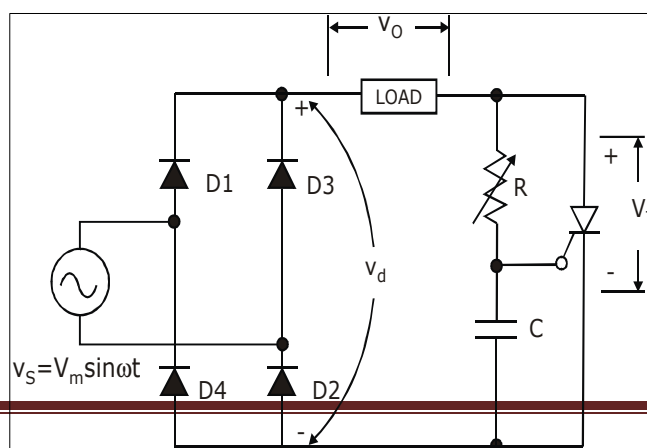

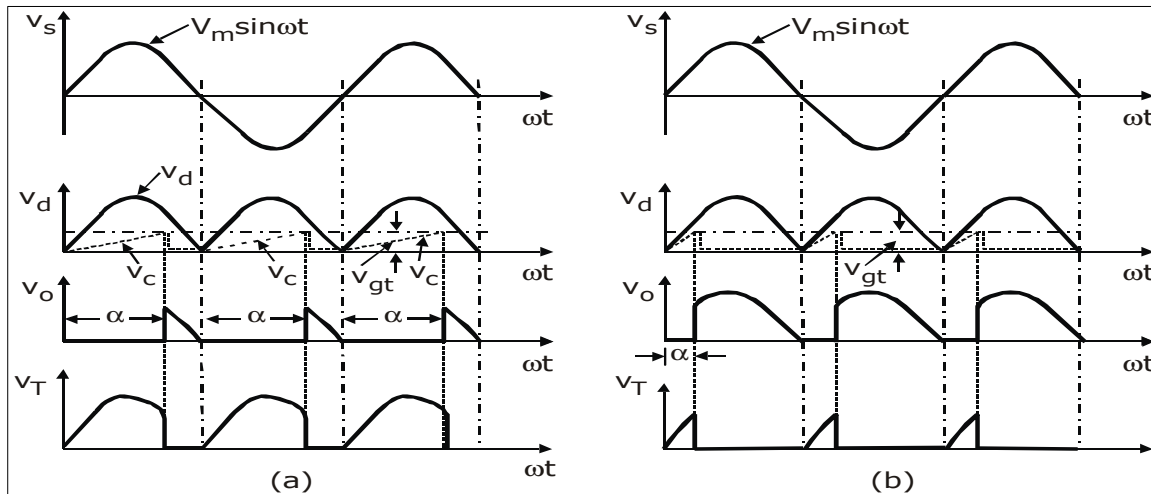

Fig 3.10: RC full-wave trigger circuit Fig: Wave-forms for RC full-wave trigger circuit

(a) High value of R

(b) Low value of R

PROBLEM

1. Design a suitable RC triggering circuit for a thyristorised network operation on a 220V, 50Hz supply. The specifications of SCR are $V_{gt\min} = 5V$, $I_{gt\max} = 30mA$.

$$R = \frac{v_s - V_{gt} - V_D}{I_g} = 7143.3\Omega$$

Therefore $RC \geq 0.013$

$R \leq 7.143k\Omega$

$C \geq 1.8199\mu F$

3.7 UNI-JUNCTION TRANSISTOR (UJT)

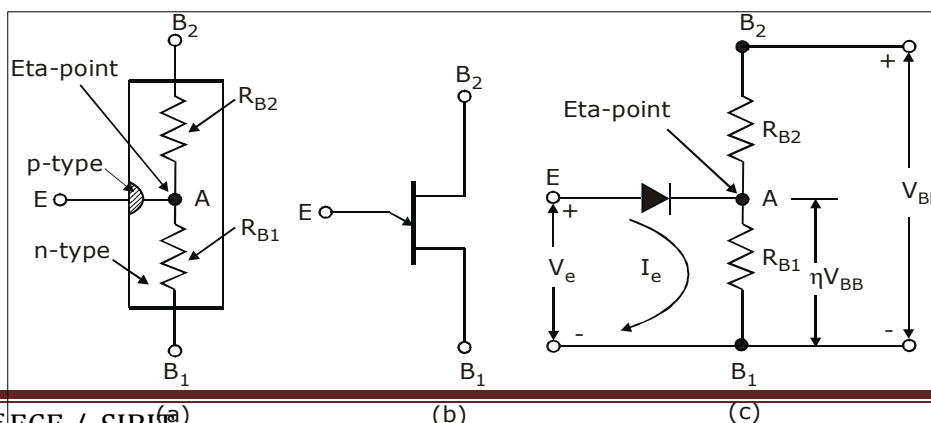

Fig.3.11: (a) Basic structure of UJT (b) Symbolic representation
(c) Equivalent circuit

UJT is an n-type silicon bar in which p-type emitter is embedded. It has three terminals base1, base2 and emitter 'E'. Between B_1 and B_2 UJT behaves like ordinary resistor and the internal resistances are given as R_{B1} and R_{B2} with emitter open $R_{BB} = R_{B1} + R_{B2}$. Usually the p-region is heavily doped and n-region is lightly doped. The equivalent circuit of UJT is as shown. When V_{BB} is applied across B_1 and B_2 , we find that potential at A is

$$V_{AB1} = \frac{V_{BB}R_{B1}}{R_{B1} + R_{B2}} = \eta V_{BB} \left[\eta = \frac{R_{B1}}{R_{B1} + R_{B2}} \right]$$

η is intrinsic stand off ratio of UJT and ranges between 0.51 and 0.82. Resistor R_{B2} is between 5 to 10K Ω .

Operation

When voltage V_{BB} is applied between emitter 'E' with base 1 B_1 as reference and the emitter voltage V_E is less than $(V_D + \eta V_{BB})$ the UJT does not conduct. $(V_D + \eta V_{BB})$ is designated as V_p which is the value of voltage required to turn on the UJT. Once V_E is equal to $V_p \equiv \eta V_{BB} + V_D$, then UJT is forward biased and it conducts.

The peak point is the point at which peak current I_p flows and the peak voltage V_p is across the UJT. After peak point the current increases but voltage across device drops, this is due to the fact that emitter starts to inject holes into the lower doped n-region. Since p-region is heavily doped compared to n-region. Also holes have a longer life time, therefore number of carriers in the base region increases rapidly. Thus potential at 'A' falls but current I_E increases rapidly. R_{B1} acts as a decreasing resistance.

The negative resistance region of UJT is between peak point and valley point. After valley point, the device acts as a normal diode since the base region is saturated and R_{B1} does not decrease again.

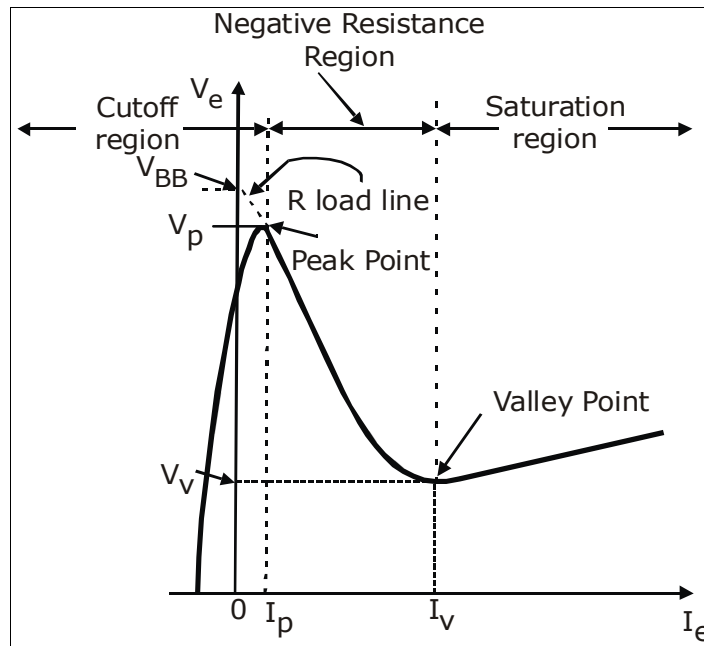

Fig.3.12: V-I Characteristics of UJT

3.8 UJT RELAXATION OSCILLATOR

UJT is highly efficient switch. The switching times is in the range of nanoseconds. Since UJT exhibits negative resistance characteristics it can be used as relaxation oscillator. The circuit diagram is as shown with R_1 and R_2 being small compared to R_{B1} and R_{B2} of UJT.

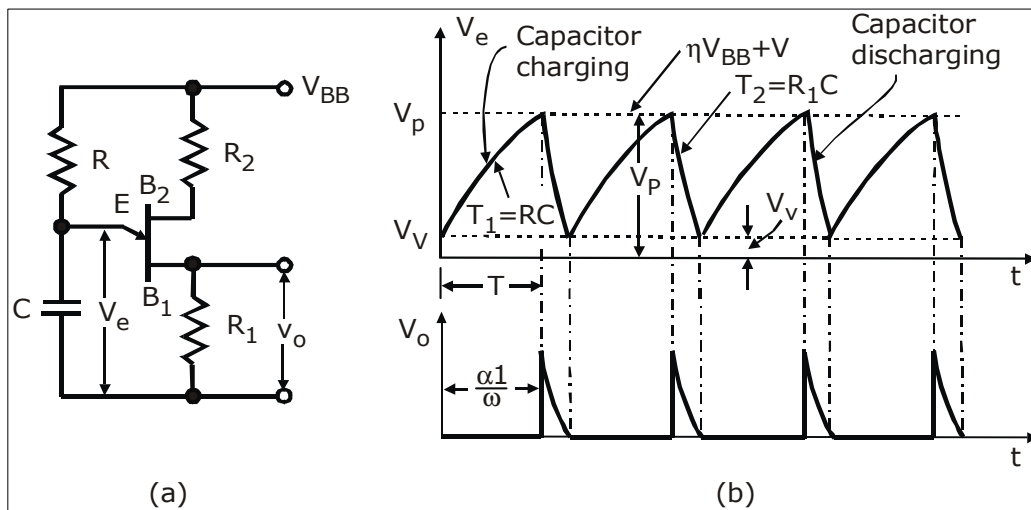

Fig.3.13: UJT oscillator (a) Connection diagram and (b) Voltage waveforms

Operation

When V_{BB} is applied, capacitor 'C' begins to charge through resistor 'R' exponentially towards V_{BB} . During this charging emitter circuit of UJT is an open circuit. The rate of charging is $\tau_1 = RC$. When this capacitor voltage which is nothing but emitter voltage V_E

reaches the peak point $V_p = \eta V_{BB} + V_D$, the emitter base junction is forward biased and UJT turns on. Capacitor 'C' rapidly discharges through load resistance R_L with time constant $\tau_2 = R_L C$ ($\tau_2 \ll \tau_1$). When emitter voltage decreases to valley point V_v , UJT turns off. Once again the capacitor will charge towards V_{BB} and the cycle continues. The rate of charging of the capacitor will be determined by the resistor R in the circuit. If R is small the capacitor charges faster towards V_{BB} and thus reaches V_p faster and the SCR is triggered at a smaller firing angle. If R is large the capacitor takes a longer time to charge towards V_p the firing angle is delayed. The waveform for both cases is as shown below.

(i) Expression for period of oscillation 't'

The period of oscillation of the UJT can be derived based on the voltage across the capacitor. Here we assume that the period of charging of the capacitor is lot larger than than the discharging time.

Using initial and final value theorem for voltage across a capacitor, we get

$$V_C = V_{final} + (V_{initial} - V_{final}) e^{-t/RC}$$

$$t = T, V_C = V_p, V_{initial} = V_v, V_{final} = V_{BB}$$

Therefore
$$V_p = V_{BB} + (V_v - V_{BB}) e^{-T/RC}$$

$$\Rightarrow T = RC \log_e \left(\frac{V_{BB} - V_v}{V_{BB} - V_p} \right)$$

If

$$V_v < V_{BB},$$

$$T = RC \ln \left(\frac{V_{BB}}{V_{BB} - V_p} \right)$$

$$= RC \ln \left[\frac{1}{1 - \frac{V_p}{V_{BB}}} \right]$$

But
$$V_p = \eta V_{BB} + V_D$$

If
$$V_D \ll V_{BB} \quad V_p = \eta V_{BB}$$

Therefore
$$T = RC \ln \left[\frac{1}{1-\eta} \right]$$

Design of UJT Oscillator

Resistor 'R' is limited to a value between 3 kilo ohms and 3 mega ohms. The upper limit on 'R' is set by the requirement that the load line formed by 'R' and V_{BB} intersects the device characteristics to the right of the peak point but to the left of valley point. If the load line fails to pass to the right of the peak point the UJT will not turn on, this condition will be satisfied if $V_{BB} - I_p R > V_p$, therefore $R < \frac{V_{BB} - V_p}{I_p}$.

At the valley point $I_E = I_v$ and $V_E = V_v$, so the condition for the lower limit on 'R' to ensure turn-off is $V_{BB} - I_v R < V_v$, therefore $R > \frac{V_{BB} - V_v}{I_v}$.

The recommended range of supply voltage is from 10 to 35V. the width of the triggering pulse $t_g = R_{B1} C$.

In general R_{B1} is limited to a value of 100 ohm and R_{B2} has a value of 100 ohm or greater and can be approximately determined as $R_{B2} = \frac{10^4}{\eta V_{BB}}$.

PROBLEM

1. A UJT is used to trigger the thyristor whose minimum gate triggering voltage is 6.2V, The UJT ratings are: $\eta = 0.66$, $I_p = 0.5mA$, $I_v = 3mA$, $R_{B1} + R_{B2} = 5k\Omega$, leakage current = 3.2mA, $V_p = 14v$ and $V_v = 1V$. Oscillator frequency is 2kHz and capacitor C = 0.04 μ F. Design the complete circuit.

Solution

$$T = R_C C \ln \left[\frac{1}{1-\eta} \right]$$

Here,

$$T = \frac{1}{f} = \frac{1}{2 \times 10^3}, \text{ since } f = 2kHz \text{ and putting other values,}$$

$$\frac{1}{2 \times 10^3} = R_C \times 0.04 \times 10^{-6} \ln \left(\frac{1}{1-0.66} \right) = 11.6k\Omega$$

The peak voltage is given as, $V_p = \eta V_{BB} + V_D$

Let $V_D = 0.8$, then putting other values,

$$14 = 0.66V_{BB} + 0.8$$

$$V_{BB} = 20V$$

The value of R_2 is given by

$$R_2 = \frac{0.7(R_{B2} + R_{B1})}{\eta V_{BB}}$$

$$R_2 = \frac{0.7(5 \times 10^3)}{0.66 \times 20}$$

$$\therefore R_2 = 265\Omega$$

Value of R_1 can be calculated by the equation

$$V_{BB} = I_{leakage} (R_1 + R_2 + R_{B1} + R_{B2})$$

$$20 = 3.2 \times 10^{-3} (R_1 + 265 + 5000)$$

$$R_1 = 985\Omega$$

The value of $R_{c(max)}$ is given by equation

$$R_{c(max)} = \frac{V_{BB} - V_p}{I_p}$$

$$R_{c(max)} = \frac{20 - 14}{0.5 \times 10^{-3}}$$

$$R_{c(max)} = 12k\Omega$$

Similarly the value of $R_{c(min)}$ is given by equation

$$R_{c(min)} = \frac{V_{BB} - V_v}{I_v}$$

$$R_{c(min)} = \frac{20 - 1}{3 \times 10^{-3}}$$

$$R_{c(min)} = 6.33k\Omega$$

- Design the UJT triggering circuit for SCR. Given $-V_{BB} = 20V$, $\eta = 0.6$, $I_p = 10\mu A$, $V_v = 2V$, $I_v = 10mA$. The frequency of oscillation is 100Hz. The triggering pulse width should be $50\mu s$.

Solution

The frequency $f = 100\text{Hz}$, Therefore $T = \frac{1}{f} = \frac{1}{100}$

From equation $T = R_c C \ln\left(\frac{1}{1-\eta}\right)$

Putting values in above equation,

$$\frac{1}{100} = R_c C \ln\left(\frac{1}{1-0.6}\right)$$

$$\therefore R_c C = 0.0109135$$

Let us select $C = 1\mu\text{F}$. Then R_c will be,

$$R_{c(\min)} = \frac{0.0109135}{1 \times 10^{-6}}$$

$$R_{c(\min)} = 10.91\text{k}\Omega.$$

The peak voltage is given as,

$$V_p = \eta V_{BB} + V_D$$

Let $V_D = 0.8$ and putting other values,

$$V_p = 0.6 \times 20 + 0.8 = 12.8\text{V}$$

The minimum value of R_c can be calculated from

$$R_{c(\min)} = \frac{V_{BB} - V_v}{I_v}$$

$$R_{c(\min)} = \frac{20 - 2}{10 \times 10^{-3}} = 1.8\text{k}\Omega$$

Value of R_2 can be calculated from

$$R_2 = \frac{10^4}{\eta V_{BB}}$$

$$R_2 = \frac{10^4}{0.6 \times 20} = 833.33\Omega$$

Here the pulse width is give, that is $50\mu\text{s}$.

Hence, value of R_1 will be,

$$\tau_2 = R_1 C$$

The width $\tau_2 = 50\mu\text{sec}$ and $C = 1\mu\text{F}$, hence above equation becomes,

$$50 \times 10^{-6} = R_1 \times 1 \times 10^{-6}$$

$$\therefore R_1 = 50\Omega$$

Thus we obtained the values of components in UJT triggering circuit as,

$$R_1 = 50\Omega, R_2 = 833.33\Omega, R_c = 10.91k\Omega, C = 1\mu\text{F}.$$

3.9 Synchronized UJT Oscillator

A synchronized UJT triggering circuit is as shown in figure below. The diodes rectify the input ac to dc, resistor R_d lowers V_{dc} to a suitable value for the zener diode and UJT. The zener diode ‘Z’ functions to clip the rectified voltage to a standard level V_z which remains constant except near $V_{dc} = 0$. This voltage V_z is applied to the charging RC circuit. The capacitor ‘C’ charges at a rate determined by the RC time constant. When the capacitor reaches the peak point V_p the UJT starts conducting and capacitor discharges through the primary of the pulse transformer. As the current through the primary is in the form of a pulse the secondary windings have pulse voltages at the output. The pulses at the two secondaries feed SCRs in phase. As the zener voltage V_z goes to zero at the end of each half cycle the synchronization of the trigger circuit with the supply voltage across the SCRs is archived, small variations in supply voltage and frequency are not going to effect the circuit operation. In case the resistor ‘R’ is reduced so that the capacitor voltage reaches UJT threshold voltage twice in each half cycle there will be two pulses in each half cycle with one pulse becoming redundant.

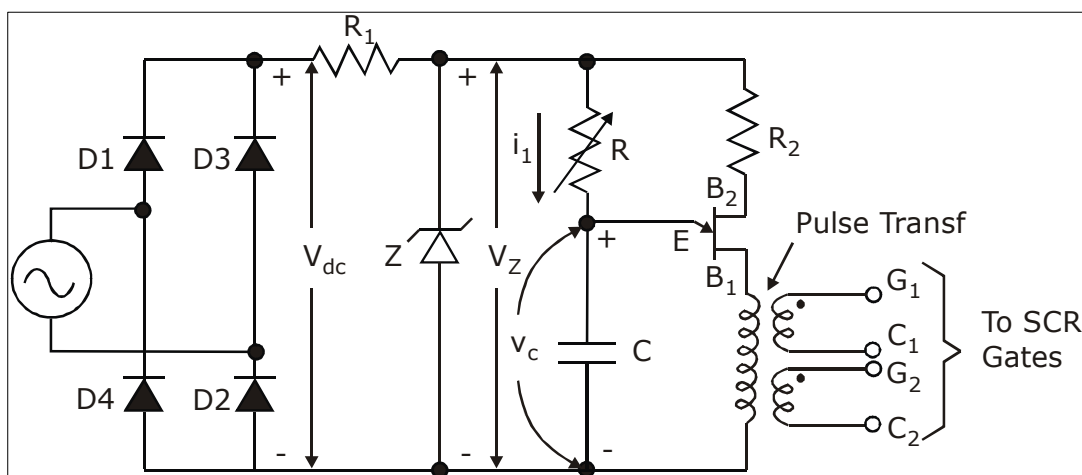

Fig.3.14: Synchronized UJT trigger circuit

Digital Firing Circuit

Fig.3.15: Block diagram of digital firing circuit

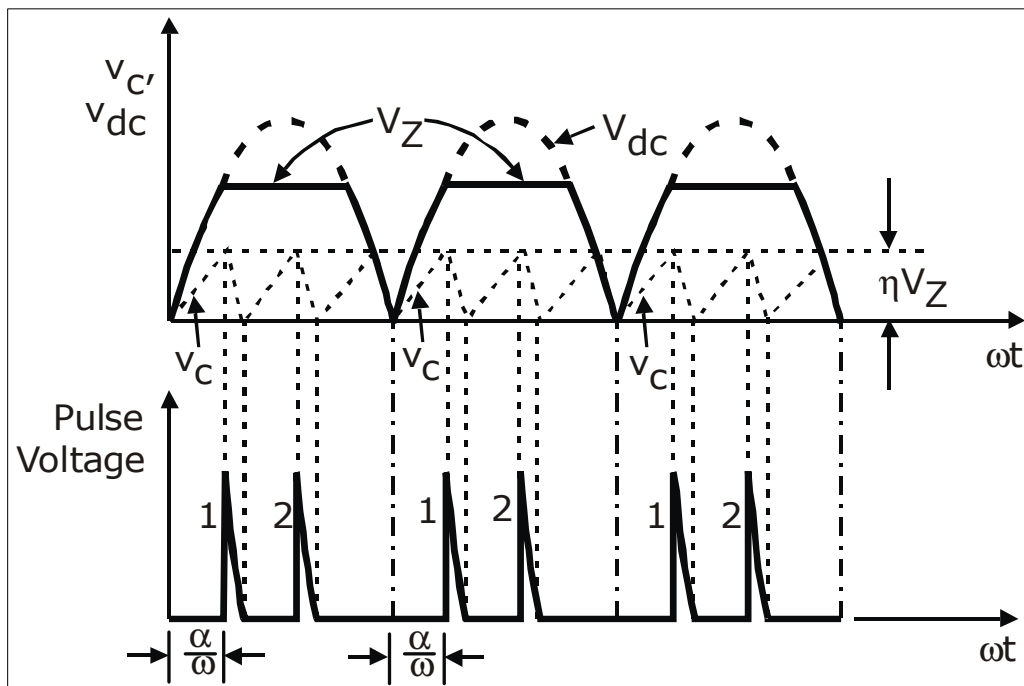
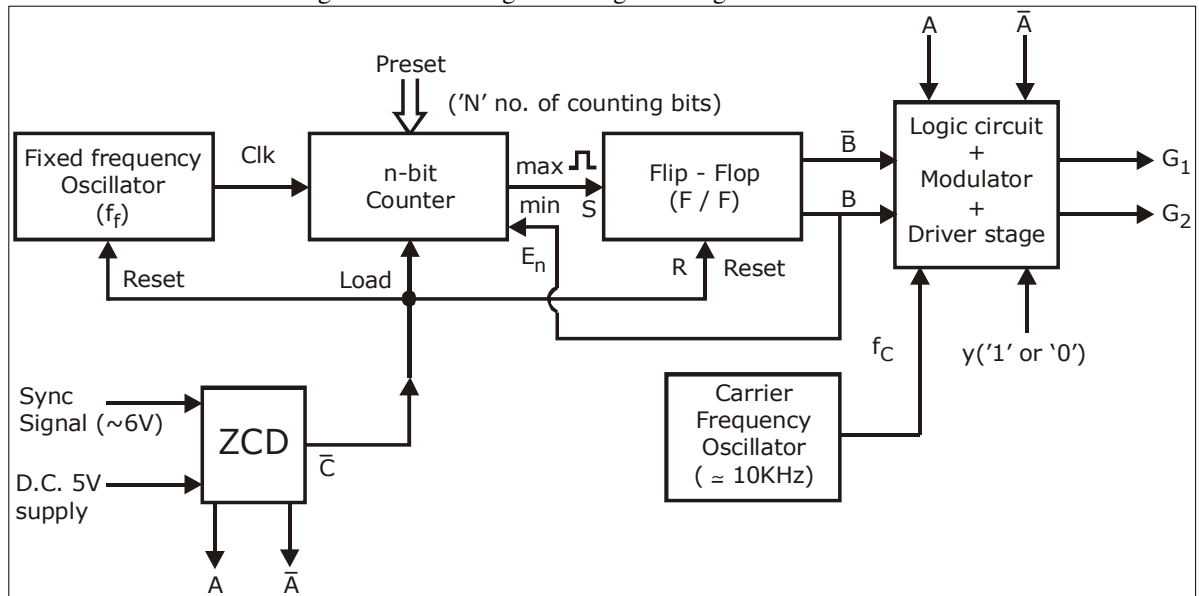

Fig.3.16: Generation of output pulses for the synchronized UJT trigger circuit

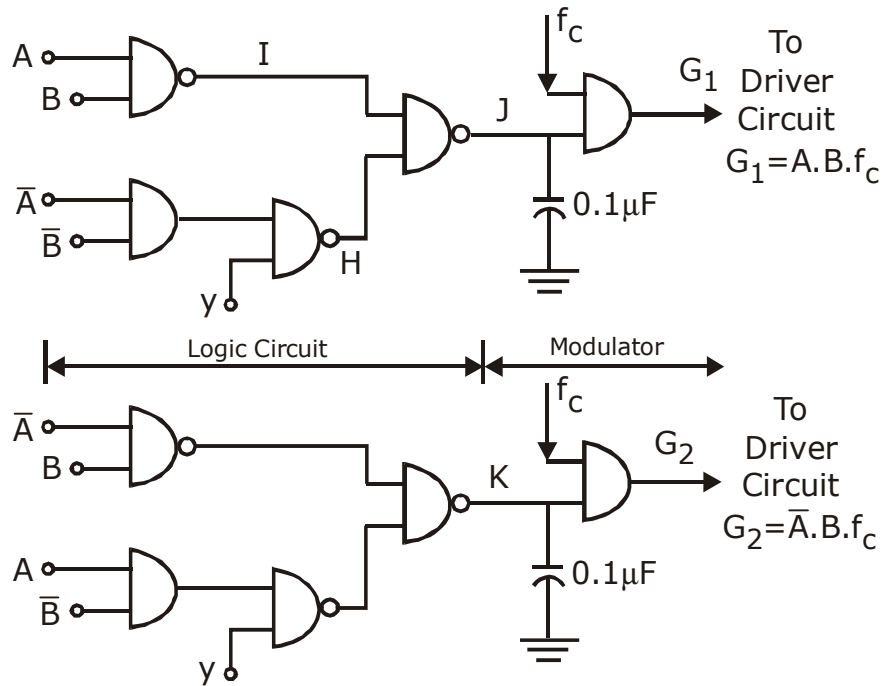

Fig.3.17: Logic circuit, Carrier Modulator

The digital firing scheme is as shown in the above figure. It constitutes a pre-settable counter, oscillator, zero crossing detection, flip-flop and a logic control unit with NAND and AND function.

Oscillator: The oscillator generates the clock required for the counter. The frequency of the clock is say f_c . In order to cover the entire range of firing angle that is from 0^0 to 180^0 , a n-bit counter is required for obtaining 2^n rectangular pulses in a half cycle of ac source. Therefore 4-bit counter is used, we obtain sixteen pulses in a half cycle of ac source.

Zero Crossing Detector: The zero crossing detector gives a short pulse whenever the input ac signal goes through zeroes. The ZCD output is used to reset the counter, oscillator and flip-flops for getting correct pulses at zero crossing point in each half cycle, a low voltage synchronized signal is used.

Counter: The counter is a pre-settable n-bit counter. It counts at the rate of f_c pulses/second. In order to cover the entire range of firing angle from 0 to 180^0 , the n-bit counter is required for obtaining 2^n rectangular pulses in a half cycle.

Example: If 4-bit counter is used there will be sixteen pulses / half cycle duration. The counter is used in the down counting mode. As soon as the synchronized signal crosses zero, the load and enable become high and low respectively and the counter starts counting the clock pulses in the down mode from the maximum value to the pre-set value 'N'. 'N' is the binary equivalent of the control signal. once the counter reaches the preset value 'N' counter overflow signal goes high. The counter overflow signal is processed to trigger the Thyristors. Thus by varying the preset input one can control the firing angle of Thyristors. The value of firing angle (α) can be calculated from the following equation

$$\alpha = \left(\frac{2^n - N}{2^n} \right) 180^0 = \left(1 - \frac{N}{16} \right) 180^0 \text{ (for } n = 4 \text{)}$$

Modified R-S Flip-Flop: The reset input terminal of flip-flop is connected to the output of ZCD and set is connected to output of counter. The pulse goes low at each zero crossing of the ac signal. A low value of ZCD output resets the B-bar to 1 and B to 0.

A high output of the counter sets B-bar to 0 and B to 1. This state of the flip-flop is latched till the next zero crossing of the synchronized signal. The output terminal B of flip-flop is connected with enable pin of counter. A high at enable 'EN' of counter stops counting till the next zero crossing.

<i>Input</i>		<i>Output</i>		<i>Remarks</i>
<i>R</i>	<i>S</i>	<i>B</i>	<i>B-bar</i>	
<i>1</i>	<i>1</i>	<i>1</i>	<i>0</i>	
<i>0</i>	<i>1</i>	<i>1</i>	<i>0</i>	<i>Set</i>
<i>0</i>	<i>0</i>	<i>0</i>	<i>1</i>	<i>Reset</i>
<i>1</i>	<i>0</i>	<i>0</i>	<i>1</i>	<i>Last Stage</i>
<i>1</i>	<i>1</i>	<i>1</i>	<i>0</i>	

Truth Table of Modified R-S Flip-Flop

Logic Circuit, Modulation and Driver Stage: The output of the flip-flop and pulses A and A-bar of ZCD are applied to the logic circuit. The logic variable Y equal to zero or one enables to select the firing pulse duration from α to π or α

Overall Operation

The input sinusoidal signal is used to derive signals A and A-bar with the help of ZCD. The zero crossing detector along with a low voltage sync signal is used to generate pulses at the instant the input goes through zeroes. The signal C and C-bar are as shown. The signal C-bar is used to reset the fixed frequency oscillator, the flip flop and the n-bit counter. The fixed frequency oscillator determines the rate at which the counter must count. The counter is preset to a value N which is the decimal equivalent of the trigger angle. The counter starts to down count as soon as the C-bar connected to load pin is zero. Once the down count N is over the counter gives a overflow signal which is processed to be given to the Thyristors. This overflow signal is given to the Set input S of the modified R-S flip flop. If S=1 B goes high as given by the truth table and B -bar has to go low. B has been connected to the Enable pin of counter. Once B goes low the counter stops counting till the next zero crossing. The carrier oscillator generates pulses with a frequency of 10kHz for generating trigger pulses for the Thyristors. Depending upon the values of A, A-bar, B, B-bar and Y the logic circuit will generate triggering pulses for gate1 or gate 2 for Thyristors 1 and 2 respectively.

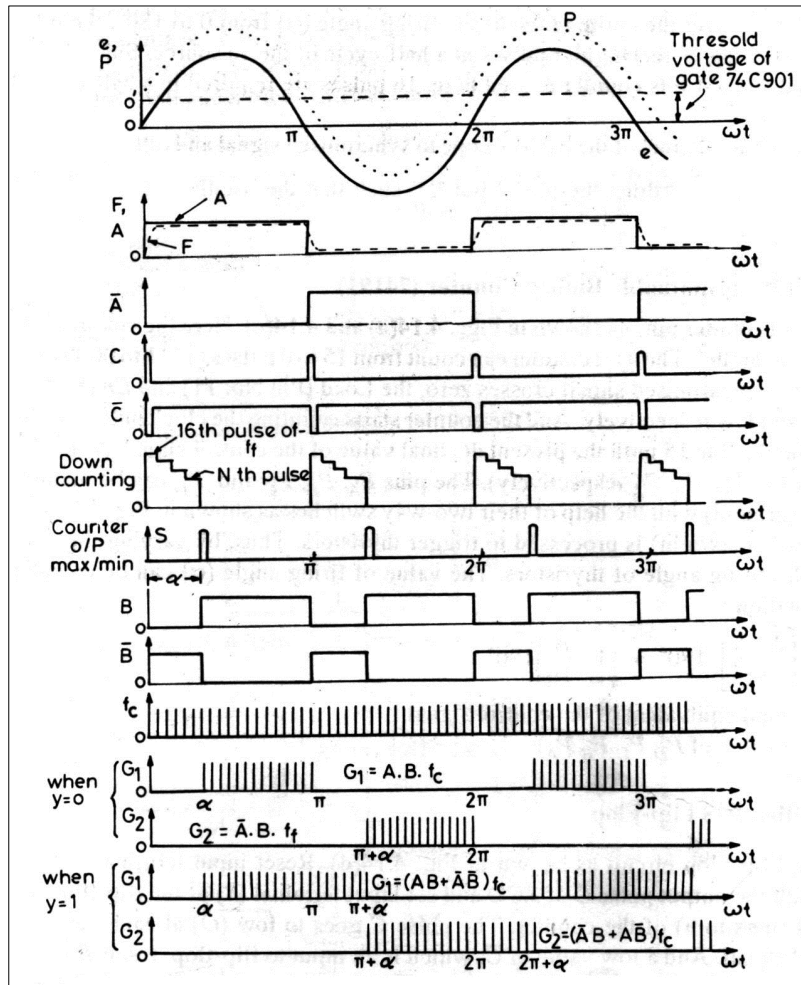

3.10 $\frac{dv}{dt}$ PROTECTION

The $\frac{dv}{dt}$ across the thyristor is limited by using snubber circuit as shown in figure (a) below. If switch S_1 is closed at $t=0$, the rate of rise of voltage across the thyristor is limited by the capacitor C_s . When thyristor T_1 is turned on, the discharge current of the capacitor is limited by the resistor R_s as shown in figure (b) below.

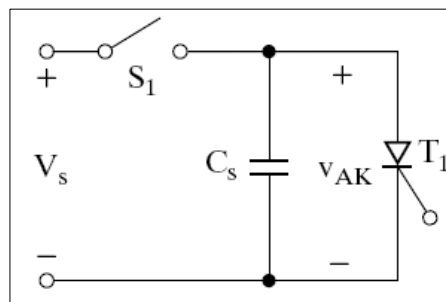

Fig.3.18 (a)

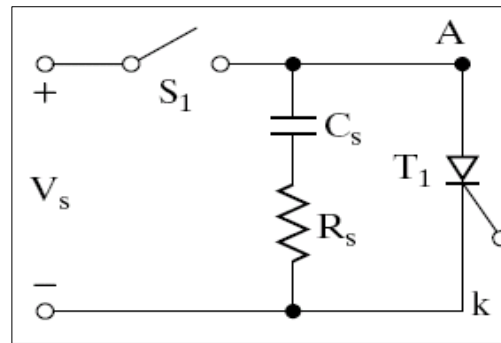

Fig.3.18 (b)

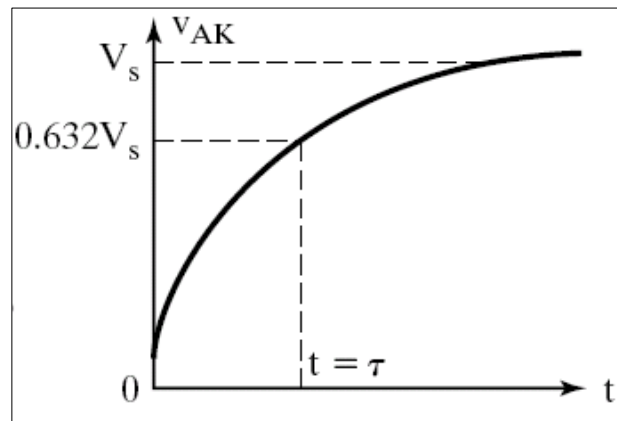

Fig.3.18 (c)

The voltage across the thyristor will rise exponentially as shown by fig (c) above. From fig. (b) above, circuit we have (for SCR off)

$$V_s = i(t)R_s + \frac{1}{C} \int i(t) dt + V_c(0)_{[for t=0]}$$

Therefore $i(t) = \frac{V_s}{R_s} e^{-t/\tau_s}$, where $\tau_s = R_s C_s$

Also $V_T(t) = V_s - i(t)R_s$

$$V_T(t) = V_s - \frac{V_s}{R_s} e^{-t/\tau_s} R_s$$

Therefore $V_T(t) = V_s - V_s e^{-t/\tau_s} = V_s \left[1 - e^{-t/\tau_s} \right]$

At $t = 0$, $V_T(0) = 0$

At $t = \tau_s$, $V_T(\tau_s) = 0.632V_s$

Therefore
$$\frac{dv}{dt} = \frac{V_T(\tau_s) - V_T(0)}{\tau_s} = \frac{0.632V_s}{R_s C_s}$$

And
$$R_s = \frac{V_s}{I_{TD}}$$

I_{TD} is the discharge current of the capacitor.

It is possible to use more than one resistor for $\frac{dv}{dt}$ and discharging as shown in the figure (d) below. The $\frac{dv}{dt}$ is limited by R_1 and C_s . $R_1 + R_2$ limits the discharging current such that
$$I_{TD} = \frac{V_s}{R_1 + R_2}$$

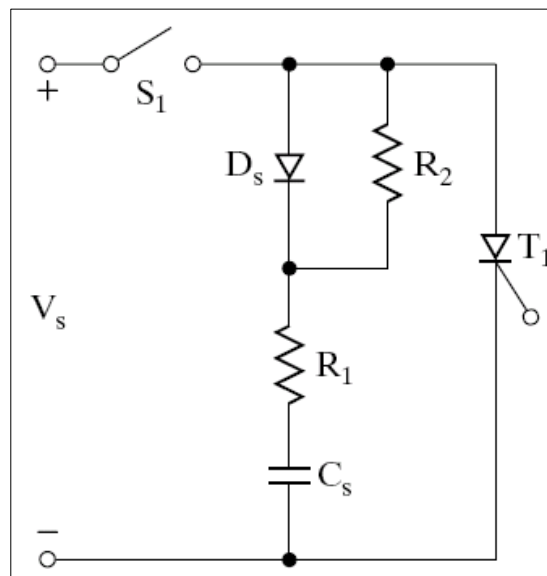

Fig.3.18 (d)

The load can form a series circuit with the snubber network as shown in figure (e) below. The damping ratio of this second order system consisting RLC network is given as,

$$\delta = \frac{\alpha}{\omega_0} = \frac{R_s + R}{2} \sqrt{\frac{C_s}{L_s + L}}, \text{ where } L_s \text{ stray inductance and } L, R \text{ is load inductance}$$

and resistance respectively.

To limit the peak overshoot applied across the thyristor, the damping ratio should be in the range of 0.5 to 1. If the load inductance is high, R_s can be high and C_s can be small to retain the desired value of damping ratio. A high value of R_s will reduce discharge current and a

low value of C_s reduces snubber loss. The damping ratio is calculated for a particular circuit R_s and C_s can be found.

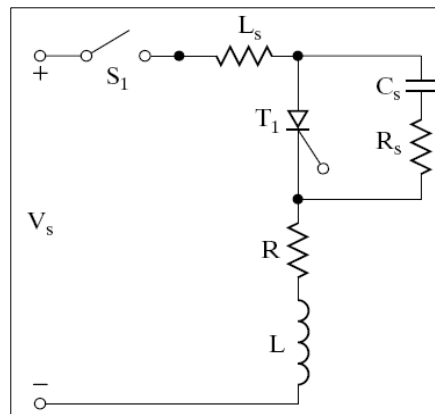
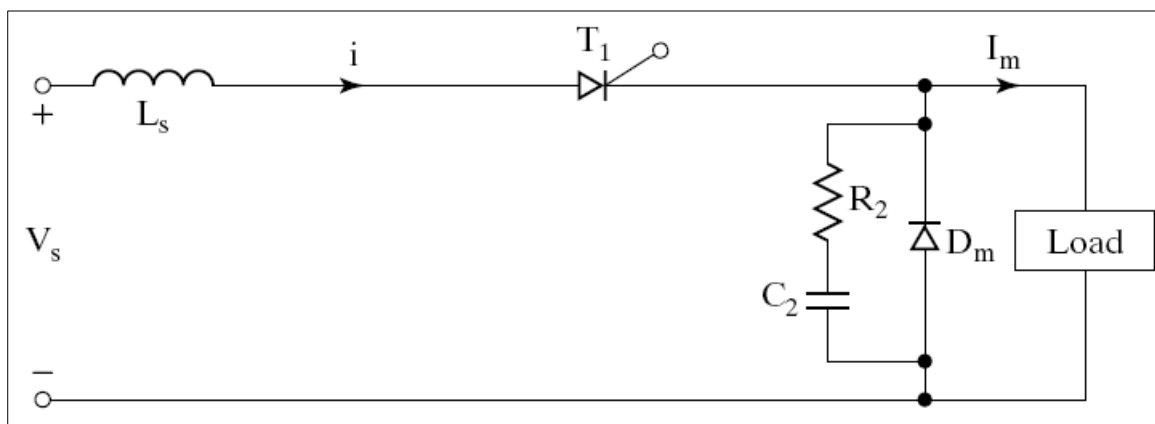

Fig.3.18 (e)

3.11 $\frac{di}{dt}$ PROTECTION



Practical devices must be protected against high $\frac{di}{dt}$. As an example let us consider the circuit shown above, under steady state operation D_m conducts when thyristor T_1 is off. If T_1 is fired when D_m is still conducting $\frac{di}{dt}$ can be very high and limited only by the stray inductance of the circuit. In practice the $\frac{di}{dt}$ is limited by adding a series inductor L_s as shown in the circuit above. Then the forward $\frac{di}{dt} = \frac{V_s}{L_s}$.

Recommended questions:

- 1 Distinguish between latching current and holding current.
2. Converter grade and inverter grade thyristors
3. Thyristor turn off and circuit turn off time
4. Peak repetitive forward blocking voltage $i^2 t$ rating
5. Explain the turn on and turn of dynamic characteristics of thyristor
6. A string of series connected thyristors is to withstand a DC voltage of 12 KV. The maximum leakage current and recovery charge differences of a thyristors are 12 mA and 120 μC respectively. A de-rating factor of 20% is applied for the steady state and dynamic (transient) voltage sharing of the thyristors. If the maximum steady state voltage is 1000V, determine 1) the steady voltage sharing resistor R for each thyristor. 2) the transient voltage capacitor C1 for each thyristor
7. A SCR is to operate in a circuit where the supply voltage is 200 VDC. The dv/dt should be limited to 100 V/ μs . Series R and C are connected across the SCR for limiting dv/dt . The maximum discharge current from C into the SCR, if and when it is turned ON is to be limited to 100 A. Using an approximate expression, obtain the values of R and C.
8. With the circuit diagram and relevant waveforms, discuss the operation of synchronized UJT firing circuit for a full wave SCR semi converter.
9. Explain gate to cathode equivalent circuit and draw the gate characteristics. Mark the operating region.
10. Mention the different turn on methods employed for a SCR
11. A SCR is having a dv/dt rating of 200 V/ μs and a di/dt rating of 100 A/ μs . This SCR is used in an inverter circuit operating at 400 VDC and has 1.5Ω source resistance. Find the values of snubber circuit components.
12. Explain the following gate triggering circuits with the help of waveforms: 1) R – triggering 2) RC – triggering.

UNIT-5

THYRISTOR COMMUTATION TECHNIQUES

5.1 Introduction

In practice it becomes necessary to turn off a conducting thyristor. (Often thyristors are used as switches to turn on and off power to the load). The process of turning off a conducting thyristor is called commutation. The principle involved is that either the anode should be made negative with respect to cathode (voltage commutation) or the anode current should be reduced below the holding current value (current commutation).

The reverse voltage must be maintained for a time at least equal to the turn-off time of SCR otherwise a reapplication of a positive voltage will cause the thyristor to conduct even without a gate signal. On similar lines the anode current should be held at a value less than the holding current at least for a time equal to turn-off time otherwise the SCR will start conducting if the current in the circuit increases beyond the holding current level even without a gate signal. Commutation circuits have been developed to hasten the turn-off process of Thyristors. The study of commutation techniques helps in understanding the transient phenomena under switching conditions.

The reverse voltage or the small anode current condition must be maintained for a time at least equal to the TURN OFF time of SCR; Otherwise the SCR may again start conducting. The techniques to turn off a SCR can be broadly classified as

- Natural Commutation
- Forced Commutation.

5.1.1 Natural Commutation (CLASS F)

This type of commutation takes place when supply voltage is AC, because a negative voltage will appear across the SCR in the negative half cycle of the supply voltage and the SCR turns off by itself. Hence no special circuits are required to turn off the SCR. That is the reason that this type of commutation is called Natural or Line Commutation. Figure 5.1 shows the circuit where natural commutation takes place and figure 1.2 shows the related waveforms. t_c is the time offered by the circuit within which the SCR should turn off completely. Thus t_c should be greater than t_q , the turn off time of the SCR. Otherwise, the SCR will become forward biased before it has turned off completely and will start conducting even without a gate signal.

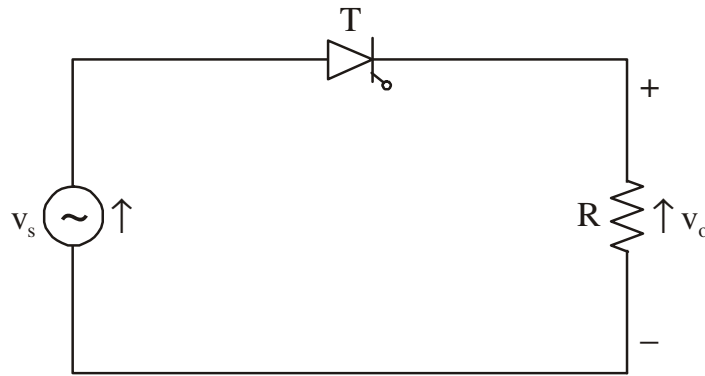

Fig. 5.1: Circuit for Natural Commutation

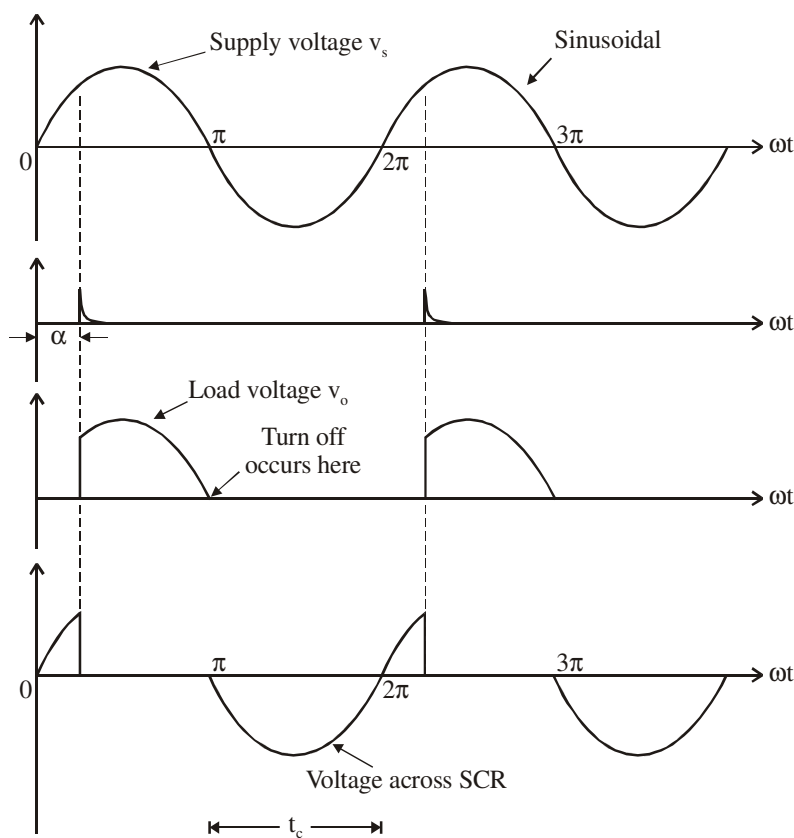

Fig. 5.2: Natural Commutation – Waveforms of Supply and Load Voltages (Resistive Load)

This type of commutation is applied in ac voltage controllers, phase controlled rectifiers and cyclo converters.

5.1.2 Forced Commutation

When supply is DC, natural commutation is not possible because the polarity of the supply remains unchanged. Hence special methods must be used to reduce the SCR current below the holding value or to apply a negative voltage across the SCR for a time interval greater than the turn off time of the SCR. This technique is called FORCED COMMUTATION and is applied in all circuits where the supply voltage is DC - namely,

Choppers (fixed DC to variable DC), inverters (DC to AC). Forced commutation techniques are as follows:

- Self Commutation
- Resonant Pulse Commutation
- Complementary Commutation
- Impulse Commutation
- External Pulse Commutation.
- Load Side Commutation.
- Line Side Commutation.

5.2 Self Commutation or Load Commutation or Class A Commutation: (Commutation By Resonating The Load)

In this type of commutation the current through the SCR is reduced below the holding current value by resonating the load. i.e., the load circuit is so designed that even though the supply voltage is positive, an oscillating current tends to flow and when the current through the SCR reaches zero, the device turns off. This is done by including an inductance and a capacitor in series with the load and keeping the circuit under-damped. Figure 5.3 shows the circuit.

This type of commutation is used in Series Inverter Circuit.

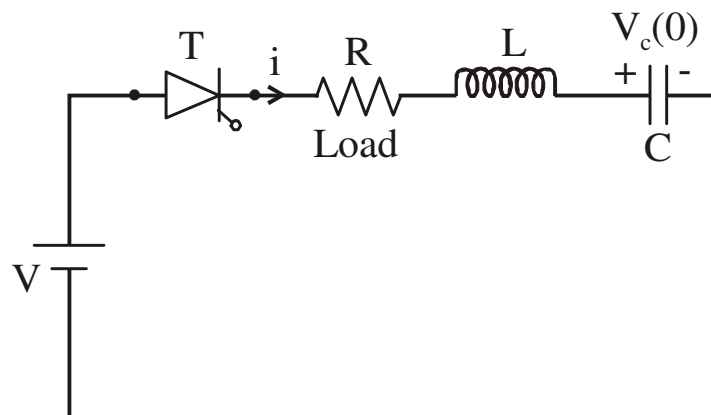

Fig. 5.3: Circuit for Self Commutation

(i) Expression for Current

At $t = 0$, when the SCR turns ON on the application of gate pulse assume the current in the circuit is zero and the capacitor voltage is $V_c(0)$.

Writing the Laplace Transformation circuit of figure 5.3 the following circuit is obtained when the SCR is conducting.

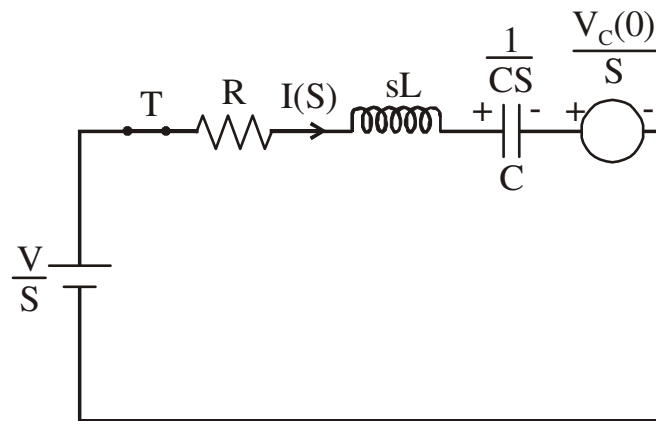

Fig.: 5.4.

$$\begin{aligned}
 I(S) &= \frac{[V - V_c(0)]}{R + sL + \frac{1}{C_s}} \\
 &= \frac{C_s [V - V_c(0)]}{RCs + s^2 LC + 1} \\
 &= \frac{C [V - V_c(0)]}{LC \left[s^2 + s \frac{R}{L} + \frac{1}{LC} \right]} \\
 &= \frac{V - V_c(0)}{s^2 + s \frac{R}{L} + \frac{1}{LC}} \\
 &= \frac{(V - V_c(0))}{L} \frac{1}{s^2 + s \frac{R}{L} + \frac{1}{LC} + \left(\frac{R}{2L} \right)^2 - \left(\frac{R}{2L} \right)^2} \\
 &= \frac{(V - V_c(0))}{L} \frac{1}{\left(s + \frac{R}{2L} \right)^2 + \left[\frac{1}{LC} - \left(\frac{R}{2L} \right)^2 \right]^2}
 \end{aligned}$$

$$= \frac{A}{(s + \delta)^2 + \omega^2},$$

Where

$$A = \frac{(V - V_c(0))}{L}, \quad \delta = \frac{R}{2L}, \quad \omega = \sqrt{\frac{1}{LC} - \left(\frac{R}{2L}\right)^2}$$

ω is called the natural frequency

$$I(S) = \frac{A}{\omega} \frac{\omega}{(s + \delta)^2 + \omega^2}$$

Taking inverse Laplace transforms

$$i(t) = \frac{A}{\omega} e^{-\delta t} \sin \omega t$$

Therefore expression for current

$$i(t) = \frac{V - V_c(0)}{\omega L} e^{-\frac{R}{2L}t} \sin \omega t$$

$$\text{Peak value of current} = \frac{(V - V_c(0))}{\omega L}$$

(ii) Expression for voltage across capacitor at the time of turn off

Applying KVL to figure 1.3

$$v_c = V - v_R - V_L$$

$$v_c = V - iR - L \frac{di}{dt}$$

Substituting for i ,

$$v_c = V - R \frac{A}{\omega} e^{-\delta t} \sin \omega t - L \frac{d}{dt} \left(\frac{A}{\omega} e^{-\delta t} \sin \omega t \right)$$

$$v_c = V - R \frac{A}{\omega} e^{-\delta t} \sin \omega t - L \frac{A}{\omega} \left(e^{-\delta t} \omega \cos \omega t - \delta e^{-\delta t} \sin \omega t \right)$$

$$v_c = V - \frac{A}{\omega} e^{-\delta t} [R \sin \omega t + \omega L \cos \omega t - L \delta \sin \omega t]$$

$$v_c = V - \frac{A}{\omega} e^{-\delta t} \left[R \sin \omega t + \omega L \cos \omega t - L \frac{R}{2L} \sin \omega t \right]$$

$$v_c = V - \frac{A}{\omega} e^{-\delta t} \left[\frac{R}{2} \sin \omega t + \omega L \cos \omega t \right]$$

Substituting for A,

$$v_c(t) = V - \frac{(V - V_c(0))}{\omega L} e^{-\delta t} \left[\frac{R}{2} \sin \omega t + \omega L \cos \omega t \right]$$

$$v_c(t) = V - \frac{(V - V_c(0))}{\omega} e^{-\delta t} \left[\frac{R}{2L} \sin \omega t + \omega \cos \omega t \right]$$

SCR turns off when current goes to zero. i.e., at $\omega t = \pi$.

Therefore at turn off

$$v_c = V - \frac{(V - V_c(0))}{\omega} e^{-\frac{\delta \pi}{\omega}} (0 + \omega \cos \pi)$$

$$v_c = V + [V - V_c(0)] e^{-\frac{\delta \pi}{\omega}}$$

Therefore
$$v_c = V + [V - V_c(0)] e^{-\frac{R\pi}{2L\omega}}$$

Note: For effective commutation the circuit should be under damped.

That is
$$\left(\frac{R}{2L} \right)^2 < \frac{1}{LC}$$

- With $R = 0$, and the capacitor initially uncharged that is $V_c(0) = 0$

$$i = \frac{V}{\omega L} \sin \frac{t}{\sqrt{LC}}$$

But
$$\omega = \frac{1}{\sqrt{LC}}$$

Therefore
$$i = \frac{V}{L} \sqrt{LC} \sin \frac{t}{\sqrt{LC}} = V \sqrt{\frac{C}{L}} \sin \frac{t}{\sqrt{LC}}$$

and capacitor voltage at turn off is equal to $2V$.

- Figure 5.5 shows the waveforms for the above conditions. Once the SCR turns off voltage across it is negative voltage.
- Conduction time of SCR = $\frac{\pi}{\omega}$.

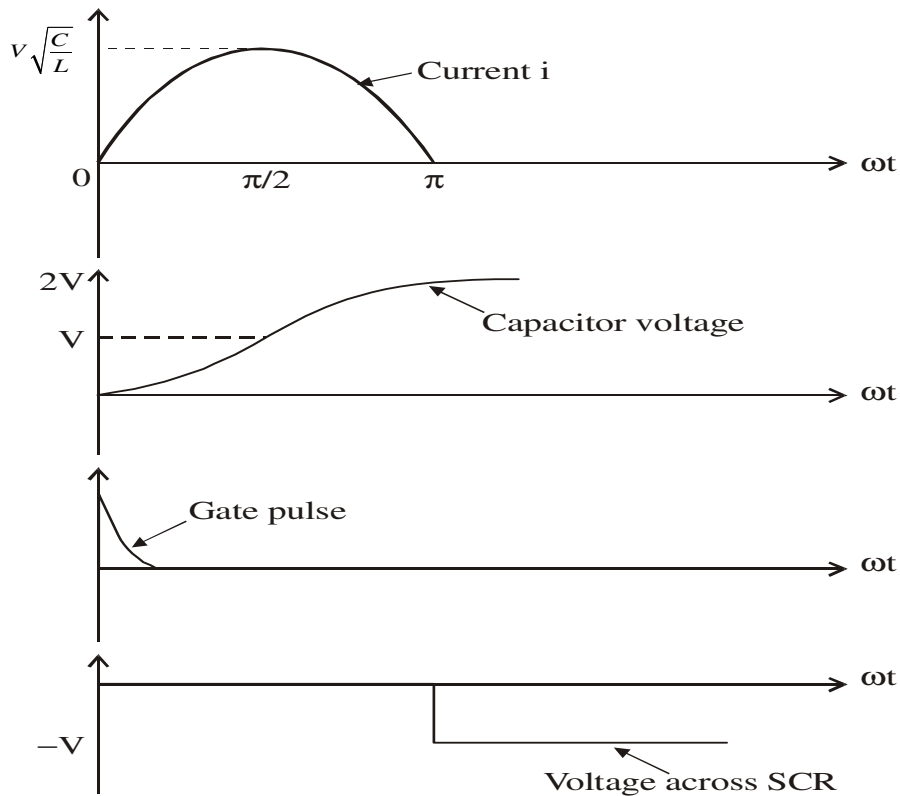

Fig. 5.5: Self Commutation – Wave forms of Current and Capacitors Voltage

Problem 5.1 : Calculate the conduction time of SCR and the peak SCR current that flows in the circuit employing series resonant commutation (self commutation or class A commutation), if the supply voltage is 300 V, $C = 1\mu\text{F}$, $L = 5\text{ mH}$ and $R_L = 100\ \Omega$. Assume that the circuit is initially relaxed.

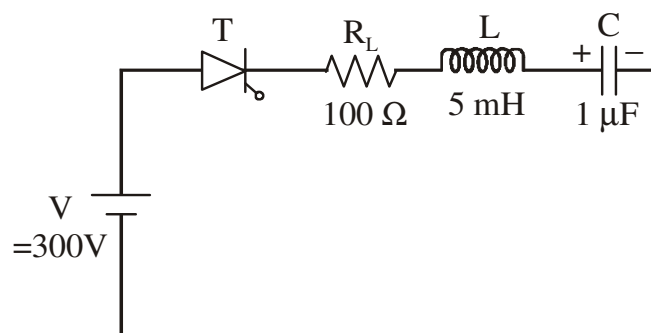

Fig. 5.6

Solution:

$$\omega = \sqrt{\frac{1}{LC} - \left(\frac{R_L}{2L}\right)^2}$$

$$\omega = \sqrt{\frac{1}{5 \times 10^{-3} \times 1 \times 10^{-6}} - \left(\frac{100}{2 \times 5 \times 10^{-3}}\right)^2}$$

$$\omega = 10,000 \text{ rad/sec}$$

Since the circuit is initially relaxed, initial voltage across capacitor is zero as also the initial current through L and the expression for current i is

$$i = \frac{V}{\omega L} e^{-\delta t} \sin \omega t, \text{ where } \delta = \frac{R}{2L},$$

Therefore peak value of $i = \frac{V}{\omega L}$

$$i = \frac{300}{10000 \times 5 \times 10^{-3}} = 6A$$

Conducting time of SCR $= \frac{\pi}{\omega} = \frac{\pi}{10000} = 0.314 \text{ msec}$

Problem 1.2: Figure 1.7 shows a self commutating circuit. The inductance carries an initial current of 200 A and the initial voltage across the capacitor is V , the supply voltage. Determine the conduction time of the SCR and the capacitor voltage at turn off.

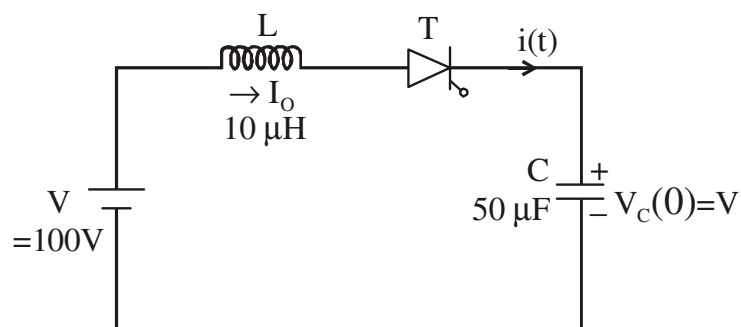

Fig. 5.7

Solution:

The transformed circuit of figure 5.7 is shown in figure 5.8.

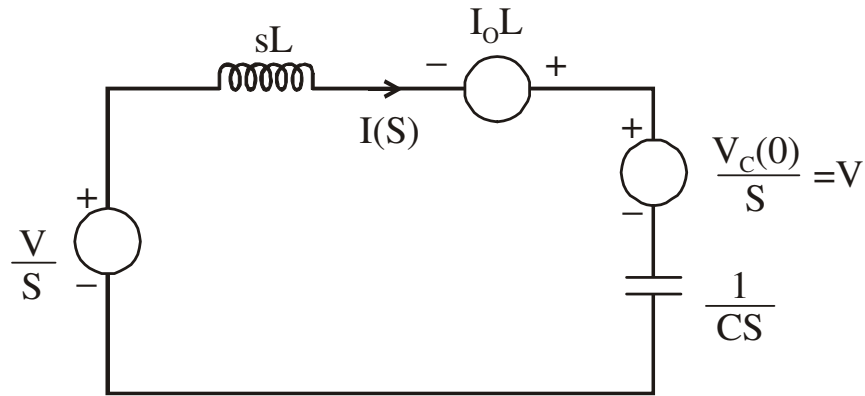

Fig.5.8: Transformed Circuit of Fig. 5.7

The governing equation is

$$\frac{V}{s} = I(S)sL - I_oL + \frac{V_c(0)}{s} + I(S)\frac{1}{Cs}$$

Therefore

$$I(S) = \frac{\frac{V}{s} - \frac{V_c(0)}{s} + I_oL}{sL + \frac{1}{Cs}}$$

$$I(S) = \frac{\left[\frac{V}{s} - \frac{V_c(0)}{s} \right] Cs}{s^2LC + 1} + \frac{I_oLCs}{s^2LC + 1}$$

$$I(S) = \frac{[V - V_c(0)]C}{LC \left[s^2 + \frac{1}{LC} \right]} + \frac{I_oLCs}{LC \left[s^2 + \frac{1}{LC} \right]}$$

$$I(S) = \frac{V - V_c(0)}{L[s^2 + \omega^2]} + \frac{sI_o}{s^2 + \omega^2}$$

$$I(S) = \frac{[V - V_c(0)]\omega}{\omega L[s^2 + \omega^2]} + \frac{sI_o}{s^2 + \omega^2} \quad \text{Where } \omega = \frac{1}{\sqrt{LC}}$$

Taking inverse LT

$$i(t) = [V - V_c(0)] \sqrt{\frac{C}{L}} \sin \omega t + I_o \cos \omega t$$

The capacitor voltage is given by

$$v_c(t) = \frac{1}{C} \int_0^t i(t) dt + V_c(0)$$

$$v_c(t) = \frac{1}{C} \int_0^t \left[[V - V_c(0)] \sqrt{\frac{C}{L}} \sin \omega t + I_o \cos \omega t \right] dt + V_c(0)$$

$$v_c(t) = \frac{1}{C} \left[\frac{(V - V_c(0))}{\omega} \sqrt{\frac{C}{L}} (-\cos \omega t)_o^t + \frac{I_o}{\omega} (\sin \omega t)_o^t + V_c(0) \right]$$

$$v_c(t) = \frac{1}{C} \left[\frac{(V - V_c(0))}{\omega} \sqrt{\frac{C}{L}} (1 - \cos \omega t) + \frac{I_o}{\omega} (\sin \omega t) + V_c(0) \right]$$

$$v_c(t) = \frac{I_o}{C} \times \sqrt{LC} \sin \omega t + \frac{1}{C} (V - V_c(0)) \sqrt{LC} \sqrt{\frac{C}{L}} (1 - \cos \omega t) + V_c(0)$$

$$v_c(t) = I_o \sqrt{\frac{L}{C}} \sin \omega t + V - V \cos \omega t - V_c(0) + V_c(0) \cos \omega t + V_c(0)$$

$$v_c(t) = I_o \sqrt{\frac{L}{C}} \sin \omega t - (V - V_c(0)) \cos \omega t + V$$

In this problem $V_c(0) = V$

Therefore we get, $i(t) = I_o \cos \omega t$ and

$$v_c(t) = I_o \sqrt{\frac{L}{C}} \sin \omega t + V$$

the waveforms are as shown in figure 1.9

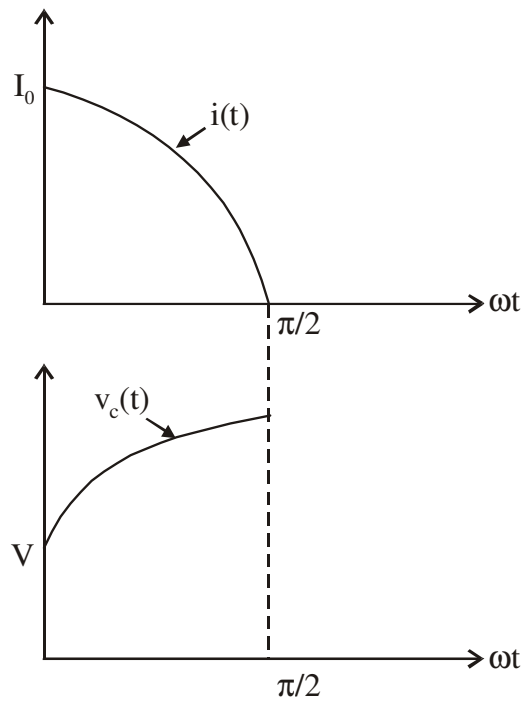

Fig.: 1.9

Turn off occurs at a time t_o so that $\omega t_o = \frac{\pi}{2}$

Therefore
$$t_o = \frac{0.5\pi}{\omega} = 0.5\pi\sqrt{LC}$$

$$t_o = 0.5 \times \pi \sqrt{10 \times 10^{-6} \times 50 \times 10^{-6}}$$

$$t_o = 0.5 \times \pi \times 10^{-6} \sqrt{500} = 35.1 \mu\text{seconds}$$

and the capacitor voltage at turn off is given by

$$v_c(t_o) = I_o \sqrt{\frac{L}{C}} \sin \omega t_o + V$$

$$v_c(t_o) = 200 \sqrt{\frac{10 \times 10^{-6}}{50 \times 10^{-6}}} \sin 90^\circ + 100$$

$$v_c(t_o) = 200 \times 0.447 \times \sin\left(\frac{35.12}{22.36}\right) + 100$$

$$v_c(t_o) = 89.4 + 100 = 189.4 \text{ V}$$

Problem 5.3: In the circuit shown in figure 1.10. $V = 600$ volts, initial capacitor voltage is zero, $L = 20 \mu\text{H}$, $C = 50\mu\text{F}$ and the current through the inductance at the time of SCR triggering is $I_0 = 350$ A. Determine (a) the peak values of capacitor voltage and current (b) the conduction time of T_1 .

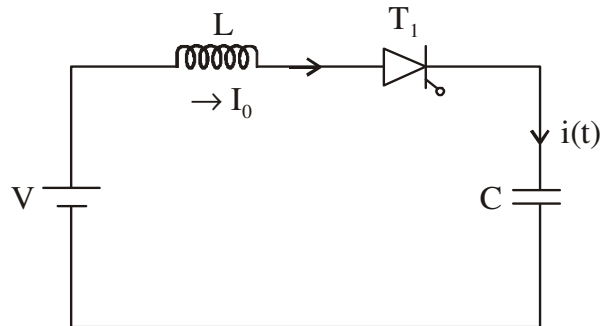

Fig. 5.10

Solution:

(Refer to problem 5.2).

The expression for $i(t)$ is given by

$$i(t) = [V - V_c(0)] \sqrt{\frac{C}{L}} \sin \omega t + I_0 \cos \omega t$$

It is given that the initial voltage across the capacitor $V_c(0)$ is zero.

Therefore
$$i(t) = V \sqrt{\frac{C}{L}} \sin \omega t + I_0 \cos \omega t$$

$i(t)$ can be written as

$$i(t) = \sqrt{I_0^2 + V^2 \frac{C}{L}} \sin(\omega t + \alpha)$$

where
$$\alpha = \tan^{-1} \frac{I_0 \sqrt{\frac{L}{C}}}{V}$$

and
$$\omega = \frac{1}{\sqrt{LC}}$$

The peak capacitor current is

$$\sqrt{I_0^2 + V^2 \frac{C}{L}}$$

Substituting the values, the peak capacitor current

$$= \sqrt{350^2 + 600^2 \times \frac{50 \times 10^{-6}}{20 \times 10^{-6}}} = 1011.19 \text{ A}$$

The expression for capacitor voltage is

$$v_c(t) = I_o \sqrt{\frac{L}{C}} \sin \omega t - (V - V_c(0)) \cos \omega t + V$$

with $V_c(0) = 0$, $v_c(t) = I_o \sqrt{\frac{L}{C}} \sin \omega t - V \cos \omega t + V$

This can be rewritten as

$$v_c(t) = \sqrt{V^2 + I_o^2 \frac{L}{C}} \sin(\omega t - \beta) + V$$

Where $\beta = \tan^{-1} \frac{V \sqrt{\frac{C}{L}}}{I_o}$

The peak value of capacitor voltage is

$$= \sqrt{V^2 + I_o^2 \frac{L}{C}} + V$$

Substituting the values, the peak value of capacitor voltage

$$= \sqrt{600^2 + 350^2 \times \frac{20 \times 10^{-6}}{50 \times 10^{-6}}} + 600$$

$$= 639.5 + 600 = 1239.5V$$

To calculate conduction time of T_1

The waveform of capacitor current is shown in figure 5.11. When the capacitor current becomes zero the SCR turns off.

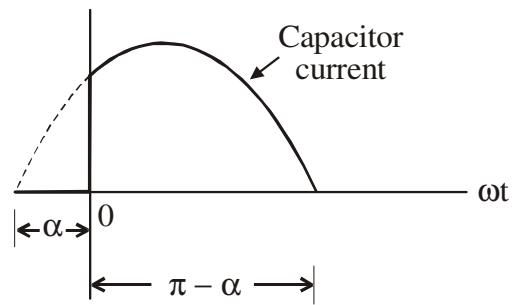

Fig. 5.11

Therefore conduction time of SCR = $\frac{\pi - \alpha}{\omega}$

$$= \frac{\pi - \tan^{-1} \left(\frac{I_o \sqrt{\frac{L}{C}}}{V} \right)}{\frac{1}{\sqrt{LC}}}$$

Substituting the values

$$\alpha = \tan^{-1} \left(\frac{I_o \sqrt{\frac{L}{C}}}{V} \right)$$

$$\alpha = \tan^{-1} \frac{350}{600} \sqrt{\frac{20 \times 10^{-6}}{50 \times 10^{-6}}}$$

$$\alpha = 20.25^\circ \text{ i.e., } 0.3534 \text{ radians}$$

$$\omega = \frac{1}{\sqrt{LC}} = \frac{1}{\sqrt{20 \times 10^{-6} \times 50 \times 10^{-6}}} = 31622.8 \text{ rad/sec}$$

Therefore conduction time of SCR

$$= \frac{\pi - 0.3534}{31622.8} = 88.17 \mu \text{ sec}$$

5.3 Resonant Pulse Commutation (Class B Commutation)

The circuit for resonant pulse commutation is shown in figure 5.12.

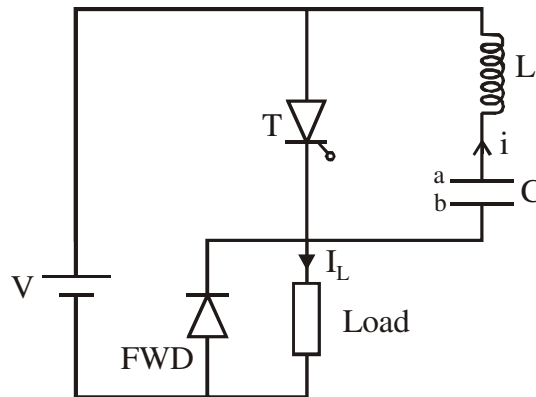

Fig. 5.12: Circuit for Resonant Pulse Commutation

This is a type of commutation in which a LC series circuit is connected across the SCR. Since the commutation circuit has negligible resistance it is always under-damped i.e., the current in LC circuit tends to oscillate whenever the SCR is on.

Initially the SCR is off and the capacitor is charged to V volts with plate 'a' being positive. Referring to figure 5.13 at $t = t_1$ the SCR is turned ON by giving a gate pulse. A current I_L flows through the load and this is assumed to be constant. At the same time SCR short circuits the LC combination which starts oscillating. A current 'i' starts flowing in the direction shown in figure. As 'i' reaches its maximum value, the capacitor voltage reduces to zero and then the polarity of the capacitor voltage reverses ('b' becomes positive). When 'i' falls to zero this reverse voltage becomes maximum, and then direction of 'i' reverses i.e., through SCR the load current I_L and 'i' flow in opposite direction. When the instantaneous value of 'i' becomes equal to I_L , the SCR current becomes zero and the SCR turns off. Now the capacitor starts charging and its voltage reaches the supply voltage with plate a being positive. The related waveforms are shown in figure 5.13.

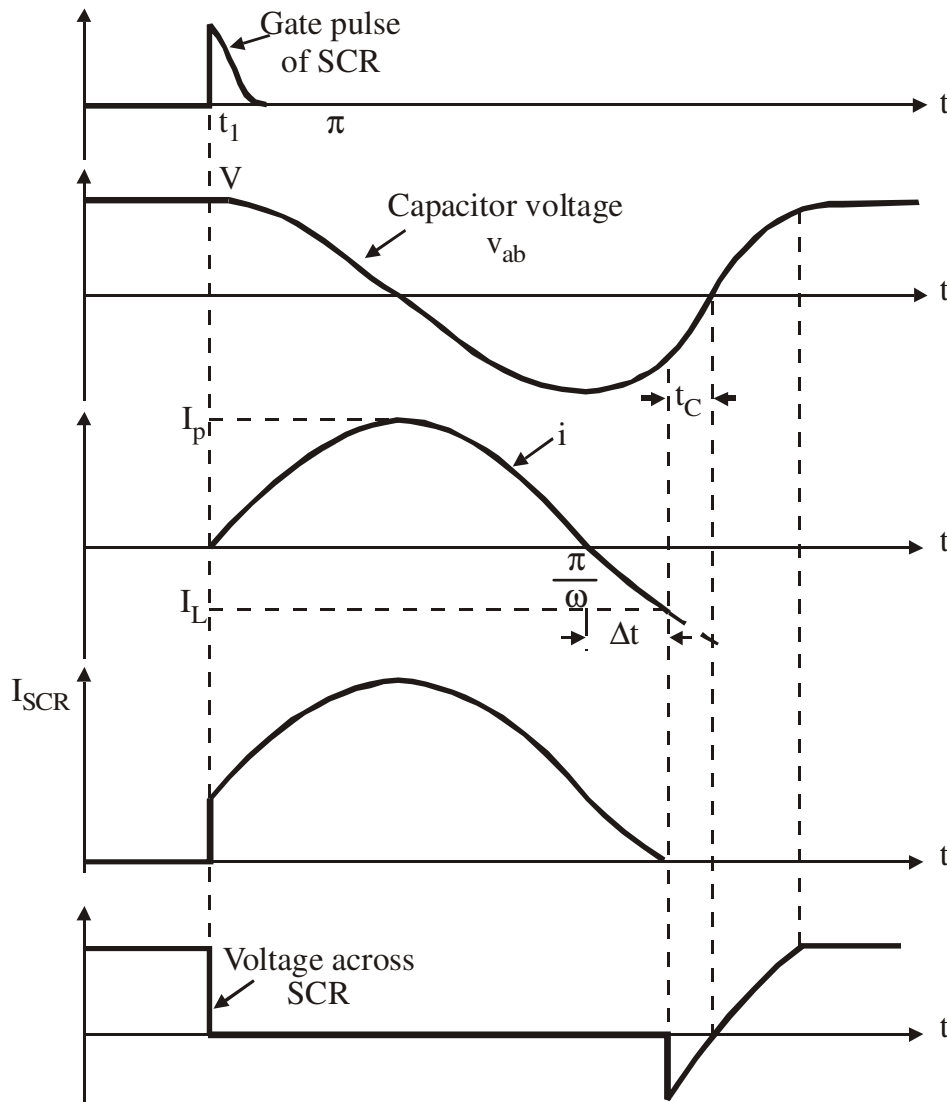

Fig. 1.13: Resonant Pulse Commutation – Various Waveforms

(i) Expression For t_c , The Circuit Turn Off Time

Assume that at the time of turn off of the SCR the capacitor voltage $v_{ab} \approx -V$ and load current I_L is constant. t_c is the time taken for the capacitor voltage to reach 0 volts from $-V$ volts and is derived as follows.

$$V = \frac{1}{C} \int_0^{t_c} I_L dt$$

$$V = \frac{I_L t_c}{C}$$

$$t_c = \frac{VC}{I_L} \text{ seconds}$$

For proper commutation t_c should be greater than t_q , the turn off time of T. Also, the magnitude of I_p , the peak value of i should be greater than the load current I_L and the expression for i is derived as follows

The LC circuit during the commutation period is shown in figure 5.14.

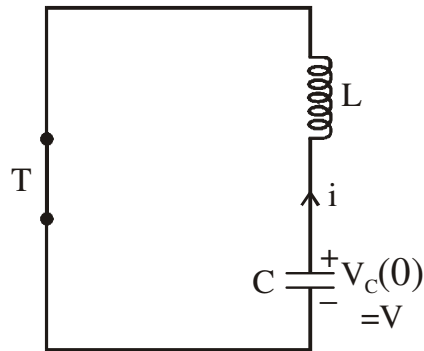

Fig. 5.14

The transformed circuit is shown in figure 5.15.

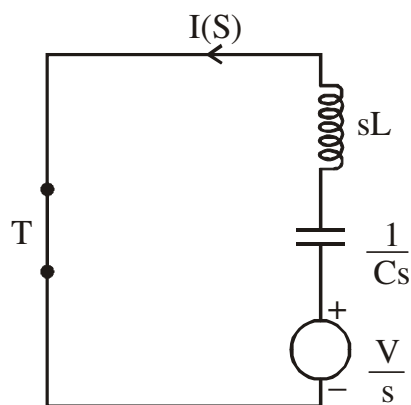

Fig. 5.15

$$I(S) = \frac{\frac{V}{s}}{sL + \frac{1}{Cs}}$$

$$I(S) = \frac{\left(\frac{V}{s}\right)Cs}{s^2LC + 1}$$

$$I(S) = \frac{VC}{LC\left(s^2 + \frac{1}{LC}\right)}$$

$$I(S) = \frac{V}{L} \times \frac{1}{s^2 + \frac{1}{LC}}$$

$$I(S) = \frac{V}{L} \times \frac{\left(\frac{1}{\sqrt{LC}}\right)}{s^2 + \frac{1}{LC}} \times \frac{1}{\left(\frac{1}{\sqrt{LC}}\right)}$$

$$I(S) = V \sqrt{\frac{C}{L}} \times \frac{\left(\frac{1}{\sqrt{LC}}\right)}{s^2 + \frac{1}{LC}}$$

Taking inverse LT

$$i(t) = V \sqrt{\frac{C}{L}} \sin \omega t$$

Where $\omega = \frac{1}{\sqrt{LC}}$

Or $i(t) = \frac{V}{\omega L} \sin \omega t = I_p \sin \omega t$

Therefore $I_p = V \sqrt{\frac{C}{L}}$ amps.

(ii) Expression for Conduction Time of SCR

For figure 5.13 (waveform of i), the conduction time of SCR

$$\begin{aligned} &= \frac{\pi}{\omega} + \Delta t \\ &= \frac{\pi}{\omega} + \frac{\sin^{-1}\left(\frac{I_L}{I_p}\right)}{\omega} \end{aligned}$$

Alternate Circuit for Resonant Pulse Commutation

The working of the circuit can be explained as follows. The capacitor C is assumed to be charged to $V_c(0)$ with polarity as shown, T_1 is conducting and the load current I_L is a constant. To turn off T_1 , T_2 is triggered. L, C, T_1 and T_2 forms a resonant circuit. A resonant

current $i_c(t)$, flows in the direction shown, i.e., in a direction opposite to that of load current I_L .

$i_c(t) = I_p \sin \omega t$ (refer to the previous circuit description). Where $I_p = V_c(0) \sqrt{\frac{C}{L}}$ & and the capacitor voltage is given by

$$v_c(t) = \frac{1}{C} \int i_c(t) . dt$$

$$v_c(t) = \frac{1}{C} \int V_c(0) \sqrt{\frac{C}{L}} \sin \omega t . dt .$$

$$v_c(t) = -V_c(0) \cos \omega t$$

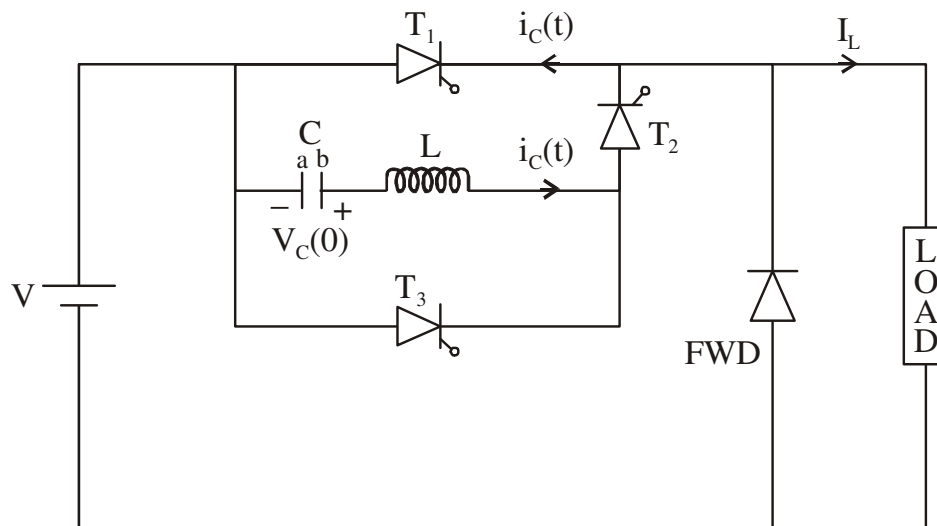

Fig. 5.16: Resonant Pulse Commutation – An Alternate Circuit

When $i_c(t)$ becomes equal to I_L (the load current), the current through T_1 becomes zero and T_1 turns off. This happens at time t_1 such that

$$I_L = I_p \sin \frac{t_1}{\sqrt{LC}}$$

$$I_p = V_c(0) \sqrt{\frac{C}{L}}$$

$$t_1 = \sqrt{LC} \sin^{-1} \left(\frac{I_L}{V_c(0) \sqrt{\frac{L}{C}}} \right)$$

and the corresponding capacitor voltage is

$$v_c(t_1) = -V_1 = -V_C(0) \cos \omega t_1$$

Once the thyristor T_1 turns off, the capacitor starts charging towards the supply voltage through T_2 and load. As the capacitor charges through the load capacitor current is same as load current I_L , which is constant. When the capacitor voltage reaches V , the supply voltage, the FWD starts conducting and the energy stored in L charges C to a still higher voltage. The triggering of T_3 reverses the polarity of the capacitor voltage and the circuit is ready for another triggering of T_1 . The waveforms are shown in figure 5.17.

Expression For t_c

Assuming a constant load current I_L which charges the capacitor

$$t_c = \frac{CV_1}{I_L} \text{ seconds}$$

Normally $V_1 \approx V_C(0)$

For reliable commutation t_c should be greater than t_q , the turn off time of SCRT₁. It is to be noted that t_c depends upon I_L and becomes smaller for higher values of load current.

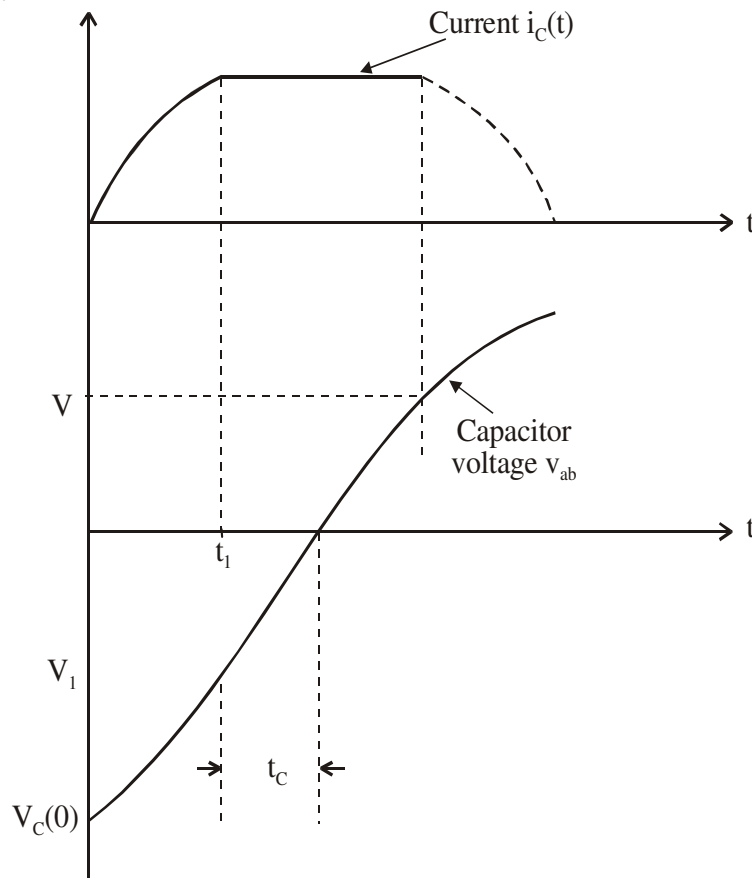

Fig. 5.17: Resonant Pulse Commutation – Alternate Circuit – Various Waveforms

Resonant Pulse Commutation with Accelerating Diode

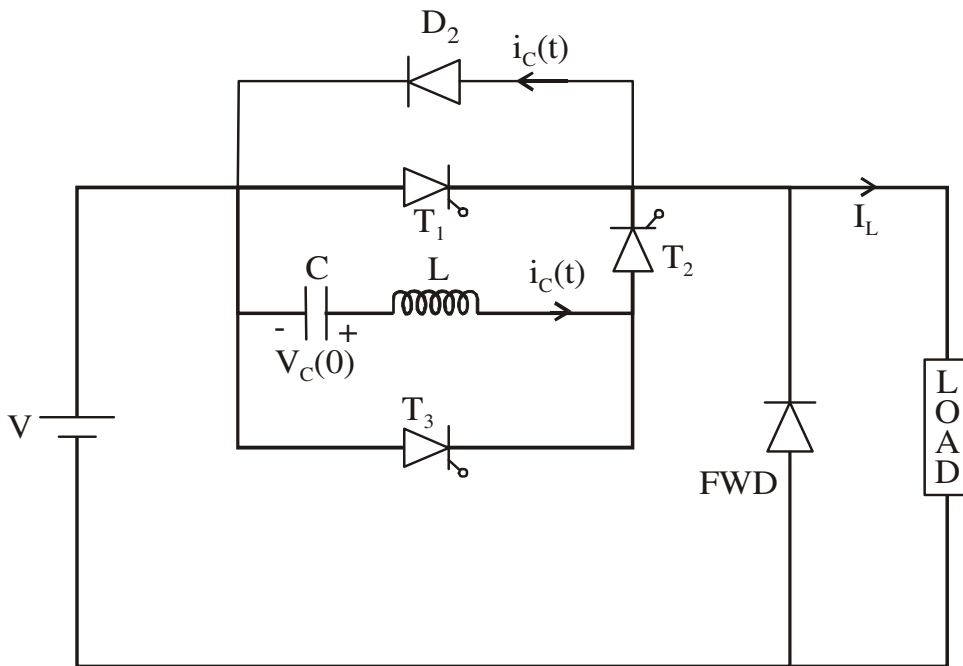

Fig. 5.17(a)

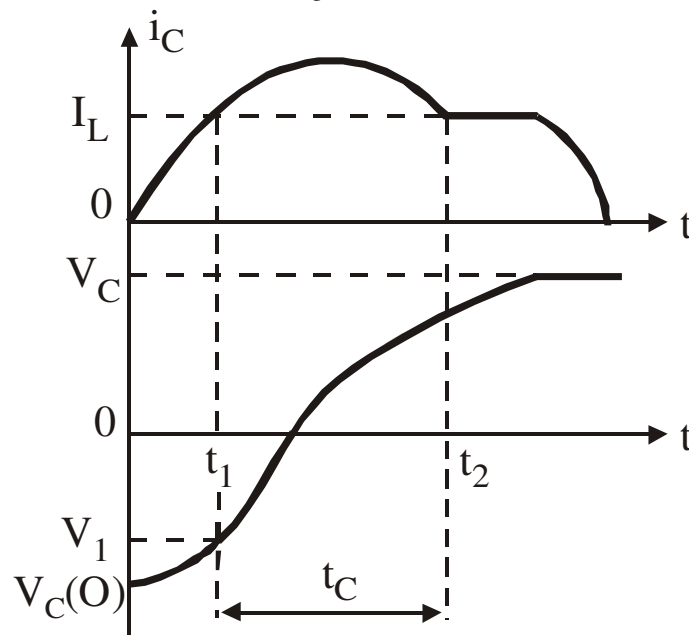

Fig. 5.17(b)

A diode D_2 is connected as shown in the figure 5.17(a) to accelerate the discharging of the capacitor 'C'. When thyristor T_2 is fired a resonant current $i_c(t)$ flows through the capacitor and thyristor T_1 . At time $t = t_1$, the capacitor current $i_c(t)$ equals the load current I_L and hence current through T_1 is reduced to zero resulting in turning off of T_1 . Now the capacitor current $i_c(t)$ continues to flow through the diode D_2 until it reduces to load current

level I_L at time t_2 . Thus the presence of D_2 has accelerated the discharge of capacitor 'C'. Now the capacitor gets charged through the load and the charging current is constant. Once capacitor is fully charged T_2 turns off by itself. But once current of thyristor T_1 reduces to zero the reverse voltage appearing across T_1 is the forward voltage drop of D_2 which is very small. This makes the thyristor recovery process very slow and it becomes necessary to provide longer reverse bias time.

From figure 5.17(b)

$$t_2 = \pi\sqrt{LC} - t_1$$

$$V_c(t_2) = -V_c(0)\cos\omega t_2$$

Circuit turn-off time $t_c = t_2 - t_1$

Problem 5.4: The circuit in figure 5.18 shows a resonant pulse commutation circuit. The initial capacitor voltage $V_{c(0)} = 200V$, $C = 30\mu F$ and $L = 3\mu H$. Determine the circuit turn off time t_c , if the load current I_L is (a) 200 A and (b) 50 A.

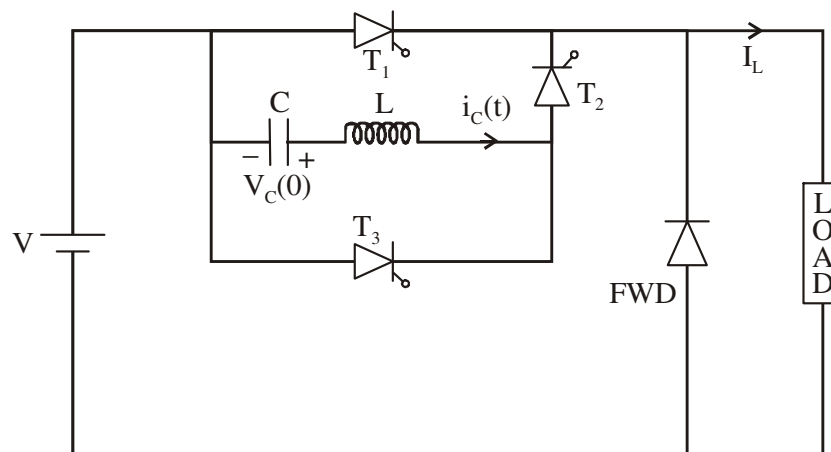

Fig. 5.18

Solution

(a) When $I_L = 200A$

Let T_2 be triggered at $t = 0$.

The capacitor current $i_c(t)$ reaches a value I_L at $t = t_1$, when T_1 turns off

$$t_1 = \sqrt{LC} \sin^{-1} \left(\frac{I_L}{V_c(0)} \sqrt{\frac{L}{C}} \right)$$

$$t_1 = \sqrt{3 \times 10^{-6} \times 30 \times 10^{-6}} \sin^{-1} \left(\frac{200}{200} \sqrt{\frac{3 \times 10^{-6}}{30 \times 10^{-6}}} \right)$$

$$t_1 = 3.05 \mu \text{ sec .}$$

$$\omega = \frac{1}{\sqrt{LC}} = \frac{1}{\sqrt{3 \times 10^{-6} \times 30 \times 10^{-6}}}$$

$$\omega = 0.105 \times 10^6 \text{ rad / sec .}$$

At $t = t_1$, the magnitude of capacitor voltage is $V_1 = V_c(0) \cos \omega t_1$

That is $V_1 = 200 \cos 0.105 \times 10^6 \times 3.05 \times 10^{-6}$

$$V_1 = 200 \times 0.9487$$

$$V_1 = 189.75 \text{ Volts}$$

and $t_c = \frac{CV_1}{I_L}$

$$t_c = \frac{30 \times 10^{-6} \times 189.75}{200} = 28.46 \mu \text{ sec .}$$

(b) When $I_L = 50 \text{ A}$

$$t_1 = \sqrt{3 \times 10^{-6} \times 30 \times 10^{-6}} \sin^{-1} \left(\frac{50}{200} \sqrt{\frac{3 \times 10^{-6}}{30 \times 10^{-6}}} \right)$$

$$t_1 = 0.749 \mu \text{ sec .}$$

$$V_1 = 200 \cos 0.105 \times 10^6 \times 0.749 \times 10^{-6}$$

$$V_1 = 200 \times 1 = 200 \text{ Volts .}$$

$$t_c = \frac{CV_1}{I_L}$$

$$t_c = \frac{30 \times 10^{-6} \times 200}{50} = 120 \mu \text{ sec .}$$

It is observed that as load current increases the value of t_c reduces.

Problem 5.4a: Repeat the above problem for $I_L = 200A$, if an antiparallel diode D_2 is connected across thyristor T_1 as shown in figure 5.18a.

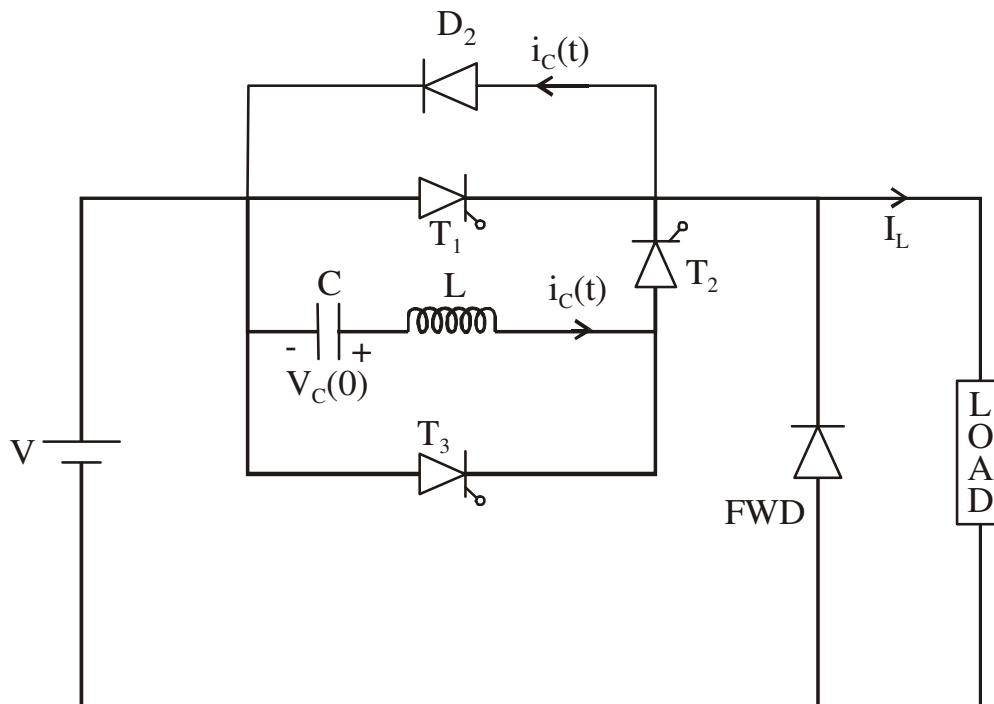

Fig. 5.18(a)

Solution

$$I_L = 200A$$

Let T_2 be triggered at $t = 0$.

Capacitor current $i_c(t)$ reaches the value I_L at $t = t_1$, when T_1 turns off

$$\text{Therefore } t_1 = \sqrt{LC} \sin^{-1} \left[\frac{I_L}{V_c(0)} \sqrt{\frac{L}{C}} \right]$$

$$t_1 = \sqrt{3 \times 10^{-6} \times 30 \times 10^{-6}} \sin^{-1} \left(\frac{200}{200} \sqrt{\frac{3 \times 10^{-6}}{30 \times 10^{-6}}} \right)$$

$$t_1 = 3.05 \mu \text{sec}.$$

$$\omega = \frac{1}{\sqrt{LC}} = \frac{1}{\sqrt{3 \times 10^{-6} \times 30 \times 10^{-6}}}$$

$$\omega = 0.105 \times 10^6 \text{ radians/sec}$$

At $t = t_1$

$$V_c(t_1) = V_1 = -V_c(O) \cos \omega t_1$$

$$V_c(t_1) = -200 \cos(0.105 \times 10^6 \times 3.05 \times 10^{-6})$$

$$V_c(t_1) = -189.75V$$

$i_c(t)$ flows through diode D_2 after T_1 turns off.

$i_c(t)$ current falls back to I_L at t_2

$$t_2 = \pi \sqrt{LC} - t_1$$

$$t_2 = \pi \sqrt{3 \times 10^{-6} \times 30 \times 10^{-6}} - 3.05 \times 10^{-6}$$

$$t_2 = 26.75 \mu \text{sec}.$$

$$\omega = \frac{1}{\sqrt{LC}} = \frac{1}{\sqrt{3 \times 10^{-6} \times 30 \times 10^{-6}}}$$

$$\omega = 0.105 \times 10^6 \text{ rad/sec.}$$

At $t = t_2$

$$V_c(t_2) = V_2 = -200 \cos 0.105 \times 10^6 \times 26.75 \times 10^{-6}$$

$$V_c(t_2) = V_2 = 189.02 V$$

Therefore $t_c = t_2 - t_1 = 26.75 \times 10^{-6} - 3.05 \times 10^{-6}$

$$t_c = 23.7 \mu \text{secs}$$

Problem 5.5: For the circuit shown in figure 5.19. Calculate the value of L for proper commutation of SCR. Also find the conduction time of SCR.

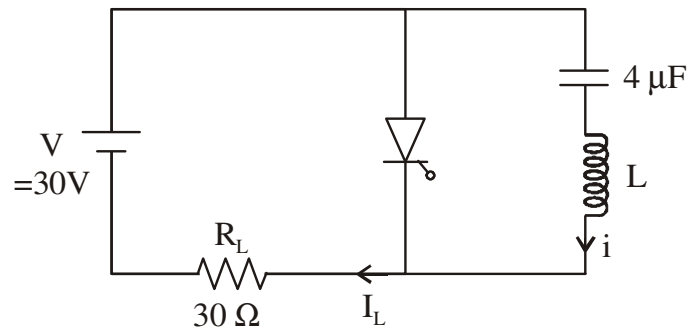

Fig. 5.19

Solution:

$$\text{The load current } I_L = \frac{V}{R_L} = \frac{30}{30} = 1 \text{ Amp}$$

For proper SCR commutation I_p , the peak value of resonant current i , should be greater than I_L ,

$$\text{Let } I_p = 2I_L, \quad \text{Therefore } I_p = 2 \text{ Amps.}$$

$$\text{Also } I_p = \frac{V}{\omega L} = \frac{V}{\frac{1}{\sqrt{LC}} \times L} = V \sqrt{\frac{C}{L}}$$

$$\text{Therefore } 2 = 30 \times \sqrt{\frac{4 \times 10^{-6}}{L}}$$

$$\text{Therefore } L = 0.9 \text{ mH.}$$

$$\omega = \frac{1}{\sqrt{LC}} = \frac{1}{\sqrt{0.9 \times 10^{-3} \times 4 \times 10^{-6}}} = 16666 \text{ rad/sec}$$

$$\text{Conduction time of SCR} = \frac{\pi}{\omega} + \frac{\sin^{-1}\left(\frac{I_L}{I_p}\right)}{\omega}$$

$$= \frac{\pi}{16666} + \frac{\sin^{-1}\left(\frac{1}{2}\right)}{16666}$$

$$= \frac{\pi + 0.523}{16666} \text{ radians}$$

$$= 0.00022 \text{ seconds}$$

$$= 0.22 \text{ msec}$$

Problem 5.6: For the circuit shown in figure 5.20 given that the load current to be commutated is 10 A, turn off time required is 40 μ sec and the supply voltage is 100 V. Obtain the proper values of commutating elements.

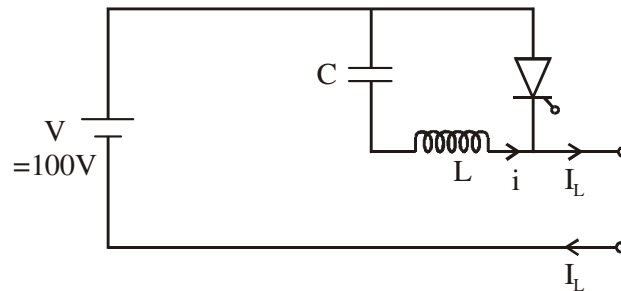

Fig. 5.20

Solution

I_p Peak value of $i = V\sqrt{\frac{C}{L}}$ and this should be greater than I_L . Let $I_p = 1.5I_L$.

$$\text{Therefore } 1.5 \times 10 = 100\sqrt{\frac{C}{L}} \quad \dots(a)$$

Also, assuming that at the time of turn off the capacitor voltage is approximately equal to V (and referring to waveform of capacitor voltage in figure 5.13) and the load current linearly charges the capacitor

$$t_c = \frac{CV}{I_L} \text{ seconds}$$

and this t_c is given to be 40 μ sec.

$$\text{Therefore } 40 \times 10^{-6} = C \times \frac{100}{10}$$

$$\text{Therefore } C = 4 \mu F$$

Substituting this in equation (a)

$$1.5 \times 10 = 100\sqrt{\frac{4 \times 10^{-6}}{L}}$$

$$1.5^2 \times 10^2 = \frac{10^4 \times 4 \times 10^{-6}}{L}$$

$$\text{Therefore } L = 1.777 \times 10^{-4} H$$

$$L = 0.177 mH .$$

Problem 5.7: In a resonant commutation circuit supply voltage is 200 V. Load current is 10 A and the device turn off time is 20 μ s. The ratio of peak resonant current to load current is 1.5. Determine the value of L and C of the commutation circuit.

Solution

Given $\frac{I_p}{I_L} = 1.5$

Therefore $I_p = 1.5I_L = 1.5 \times 10 = 15A$.

That is $I_p = V \sqrt{\frac{C}{L}} = 15A \quad \dots(a)$

It is given that the device turn off time is 20 μ sec. Therefore t_c , the circuit turn off time should be greater than this,

Let $t_c = 30\mu \text{ sec}.$

And $t_c = \frac{CV}{I_L}$

Therefore $30 \times 10^{-6} = \frac{200 \times C}{10}$

Therefore $C = 1.5\mu F.$

Substituting in (a)

$$15 = 200 \sqrt{\frac{1.5 \times 10^{-6}}{L}}$$

$$15^2 = 200^2 \times \frac{1.5 \times 10^{-6}}{L}$$

Therefore $L = 0.2666 \text{ mH}$

5.4 Complementary Commutation (Class C Commutation, Parallel Capacitor Commutation)

In complementary commutation the current can be transferred between two loads. Two SCRs are used and firing of one SCR turns off the other. The circuit is shown in figure 5.21.

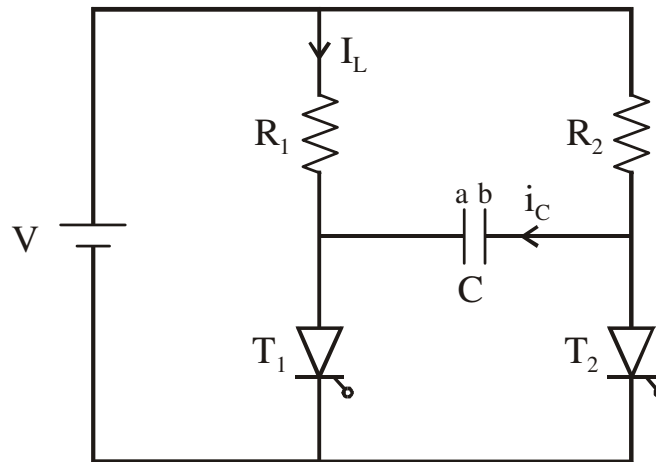

Fig. 5.21: Complementary Commutation

The working of the circuit can be explained as follows.

Initially both T_1 and T_2 are off; now, T_1 is fired. Load current I_L flows through R_1 . At the same time, the capacitor C gets charged to V volts through R_2 and T_1 ('b' becomes positive with respect to 'a'). When the capacitor gets fully charged, the capacitor current i_c becomes zero.

To turn off T_1 , T_2 is fired; the voltage across C comes across T_1 and reverse biases it, hence T_1 turns off. At the same time, the load current flows through R_2 and T_2 . The capacitor 'C' charges towards V through R_1 and T_2 and is finally charged to V volts with 'a' plate positive. When the capacitor is fully charged, the capacitor current becomes zero. To turn off T_2 , T_1 is triggered, the capacitor voltage (with 'a' positive) comes across T_2 and T_2 turns off. The related waveforms are shown in figure 5.22.

(i) Expression for Circuit Turn Off Time t_c

From the waveforms of the voltages across T_1 and capacitor, it is obvious that t_c is the time taken by the capacitor voltage to reach 0 volts from $-V$ volts, the time constant being RC and the final voltage reached by the capacitor being V volts. The equation for capacitor voltage $v_c(t)$ can be written as

$$v_c(t) = V_f + (V_i - V_f) e^{-t/\tau}$$

Where V_f is the final voltage, V_i is the initial voltage and τ is the time constant.

At $t = t_c$, $v_c(t) = 0$,

$$\tau = R_1 C, V_f = V, V_i = -V,$$

Therefore $0 = V + (-V - V)e^{\frac{-t_c}{R_1 C}}$

$$0 = V - 2Ve^{\frac{-t_c}{R_1 C}}$$

Therefore $V = 2Ve^{\frac{-t_c}{R_1 C}}$

$$0.5 = e^{\frac{-t_c}{R_1 C}}$$

Taking natural logarithms on both sides

$$\ln 0.5 = \frac{-t_c}{R_1 C}$$

$$t_c = 0.693R_1 C$$

This time should be greater than the turn off time t_q of T_1 .

Similarly when T_2 is commutated

$$t_c = 0.693R_2 C$$

And this time should be greater than t_q of T_2 .

Usually $R_1 = R_2 = R$

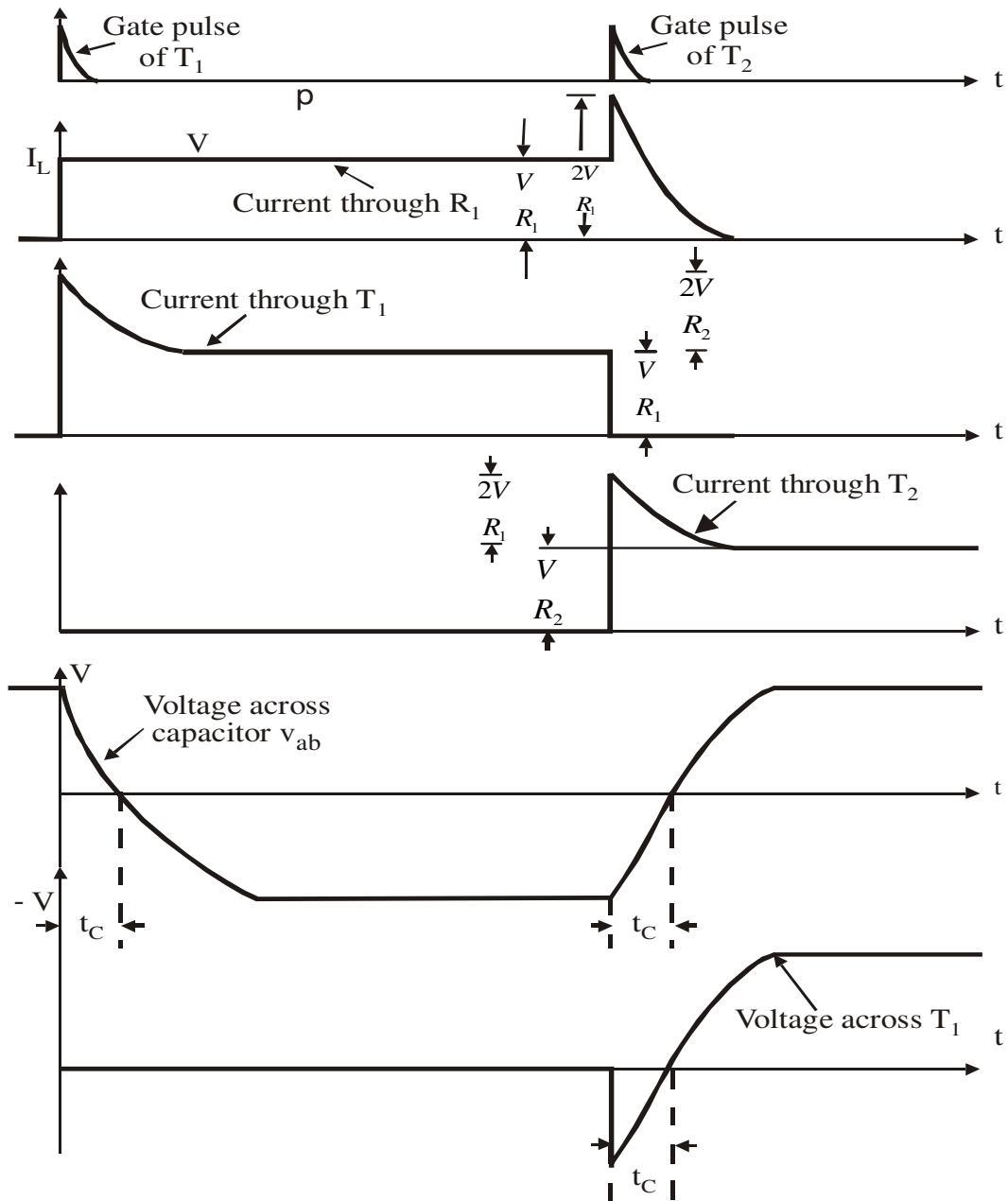

Fig. 5.22

Problem 5.8: In the circuit shown in figure 1.23 the load resistances $R_1 = R_2 = R = 5\Omega$ and the capacitance $C = 7.5 \mu\text{F}$, $V = 100$ volts. Determine the circuits turn off time t_c .

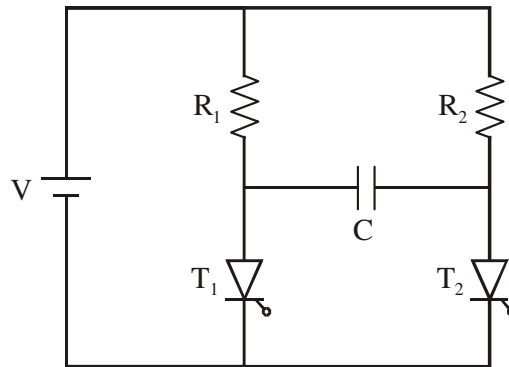

Fig. 5.23

Solution

The circuit turn-off time $t_c = 0.693 RC$ seconds

$$t_c = 0.693 \times 5 \times 7.5 \times 10^{-6}$$

$$t_c = 26 \mu\text{sec}.$$

Problem 5.9: Calculate the values of R_L and C to be used for commutating the main SCR in the circuit shown in figure 1.24. When it is conducting a full load current of 25 A flows. The minimum time for which the SCR has to be reverse biased for proper commutation is $40 \mu\text{sec}$. Also find R_1 , given that the auxiliary SCR will undergo natural commutation when its forward current falls below the holding current value of 2 mA.

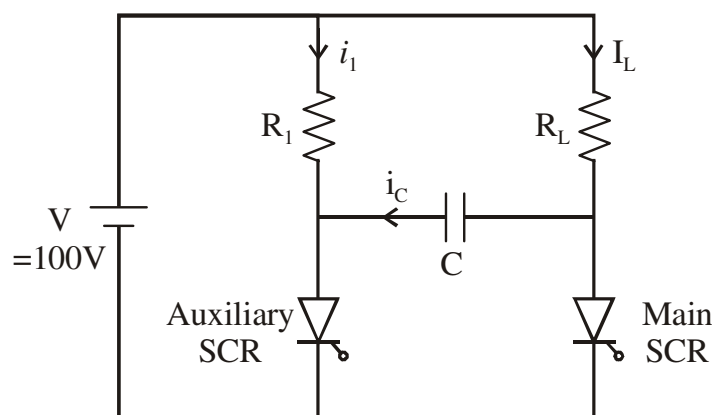

Fig. 5.24

Solution

In this circuit only the main SCR carries the load and the auxiliary SCR is used to turn off the main SCR. Once the main SCR turns off the current through the auxiliary SCR is the sum of the capacitor charging current i_c and the current i_1 through R_1 , i_c reduces to zero after

a time t_c and hence the auxiliary SCR turns off automatically after a time t_c , i_1 should be less than the holding current.

Given $I_L = 25A$

That is $25A = \frac{V}{R_L} = \frac{100}{R_L}$

Therefore $R_L = 4\Omega$

$$t_c = 40\mu\text{sec} = 0.693R_L C$$

That is $40 \times 10^{-6} = 0.693 \times 4 \times C$

Therefore $C = \frac{40 \times 10^{-6}}{4 \times 0.693}$

$$C = 14.43\mu F$$

$i_1 = \frac{V}{R_1}$ should be less than the holding current of auxiliary SCR.

Therefore $\frac{100}{R_1}$ should be $< 2\text{mA}$.

Therefore $R_1 > \frac{100}{2 \times 10^{-3}}$

That is $R_1 > 50K\Omega$

5.5 Impulse Commutation (CLASS D Commutation)

The circuit for impulse commutation is as shown in figure 5.25.

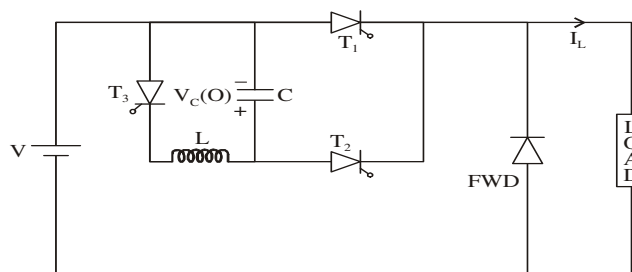

Fig. 5.25: Circuit for Impulse Commutation

The working of the circuit can be explained as follows. It is assumed that initially the capacitor C is charged to a voltage $V_c(O)$ with polarity as shown. Let the thyristor T_1 be

conducting and carry a load current I_L . If the thyristor T_1 is to be turned off, T_2 is fired. The capacitor voltage comes across T_1 , T_1 is reverse biased and it turns off. Now the capacitor starts charging through T_2 and the load. The capacitor voltage reaches V with top plate being positive. By this time the capacitor charging current (current through T_2) would have reduced to zero and T_2 automatically turns off. Now T_1 and T_2 are both off. Before firing T_1 again, the capacitor voltage should be reversed. This is done by turning on T_3 , C discharges through T_3 and L and the capacitor voltage reverses. The waveforms are shown in figure 5.26.

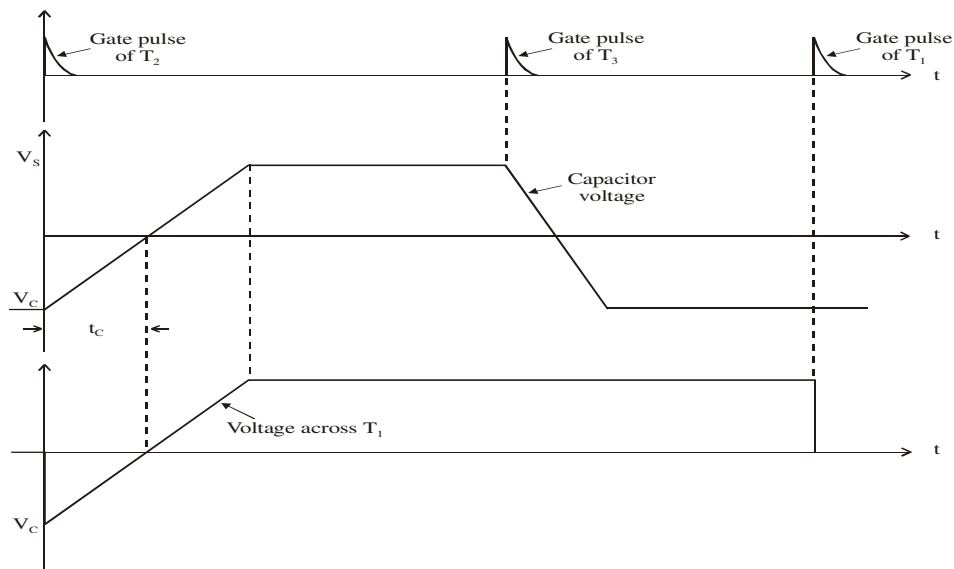

Fig. 5.26: Impulse Commutation – Waveforms of Capacitor Voltage, Voltage across T_1 .

(i) Expression for Circuit Turn Off Time (Available Turn Off Time) t_c

t_c depends on the load current I_L and is given by the expression

$$V_C = \frac{1}{C} \int_0^{t_c} I_L dt$$

(assuming the load current to be constant)

$$V_C = \frac{I_L t_c}{C}$$

$$t_c = \frac{V_C C}{I_L} \text{ seconds}$$

For proper commutation t_c should be $> t_q$, turn off time of T_1 .

Note:

- T_1 is turned off by applying a negative voltage across its terminals. Hence this is voltage commutation.
- t_c depends on load current. For higher load currents t_c is small. This is a disadvantage of this circuit.
- When T_2 is fired, voltage across the load is $V + V_c$; hence the current through load shoots up and then decays as the capacitor starts charging.

An Alternative Circuit for Impulse Commutation

Is shown in figure 5.27.

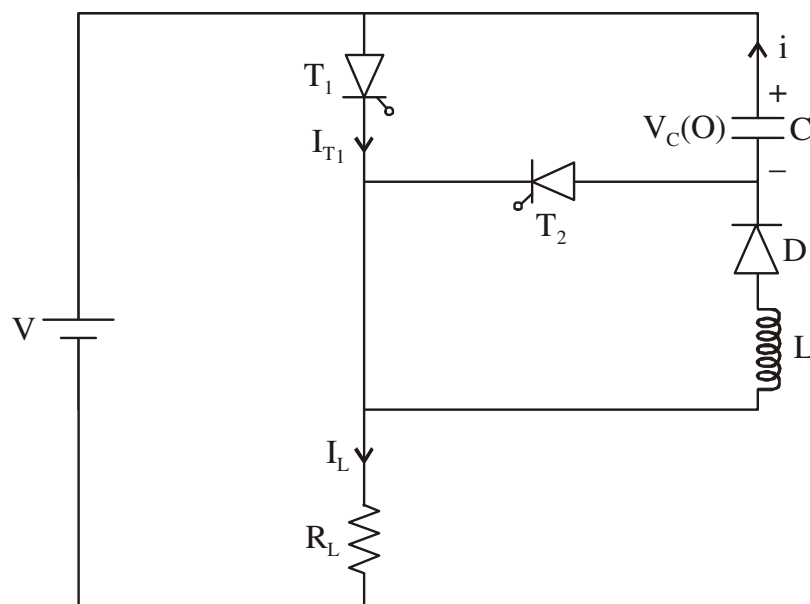

Fig. 5.27: Impulse Commutation – An Alternate Circuit

The working of the circuit can be explained as follows:

Initially let the voltage across the capacitor be $V_c(O)$ with the top plate positive. Now T_1 is triggered. Load current flows through T_1 and load. At the same time, C discharges through T_1 , L and D (the current is 'i') and the voltage across C reverses i.e., the bottom plate becomes positive. The diode D ensures that the bottom plate of the capacitor remains positive.

To turn off T_1 , T_2 is triggered; the voltage across the capacitor comes across T_1 . T_1 is reverse biased and it turns off (voltage commutation). The capacitor now starts charging through T_2 and load. When it charges to V volts (with the top plate positive), the current through T_2 becomes zero and T_2 automatically turns off.

The related waveforms are shown in figure 5.28.

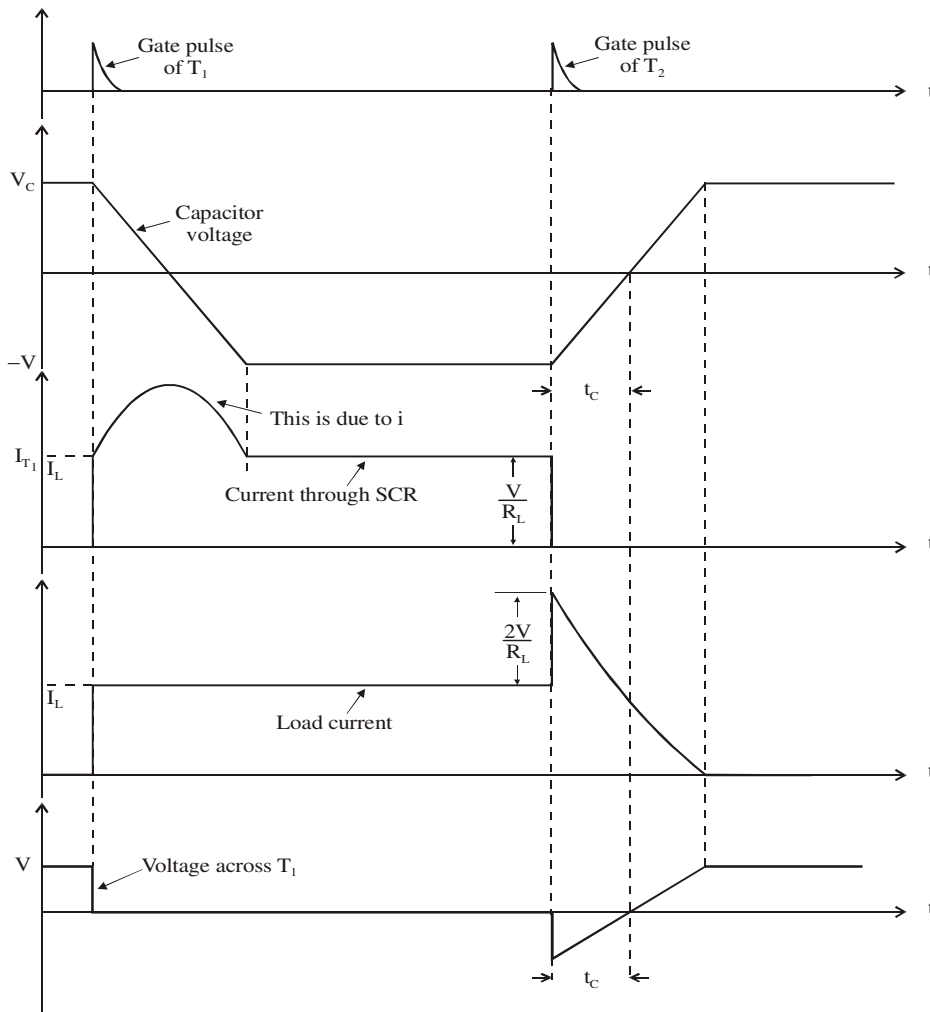

Fig. 5.28: Impulse Commutation – (Alternate Circuit) – Various Waveforms

Problem 5.10: An impulse commutated thyristor circuit is shown in figure 5.29. Determine the available turn off time of the circuit if $V = 100 \text{ V}$, $R = 10 \text{ } \Omega$ and $C = 10 \text{ } \mu\text{F}$. Voltage across capacitor before T_2 is fired is V volts with polarity as shown.

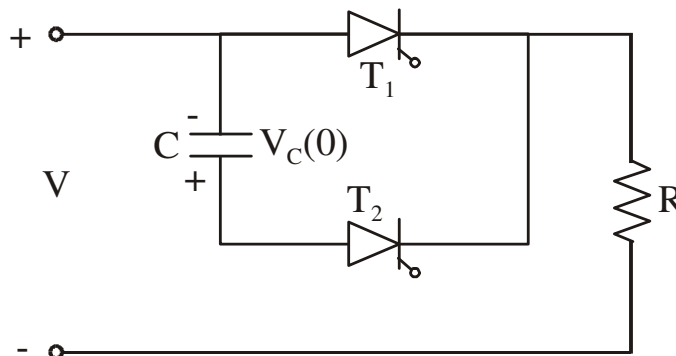

Fig. 5.29

Solution

When T_2 is triggered the circuit is as shown in figure 5.30.

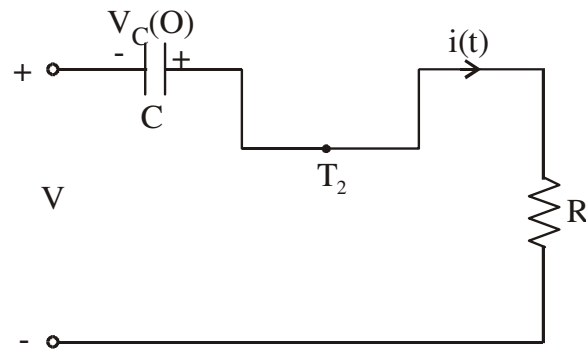

Fig. 5.30

Writing the transform circuit, we obtain

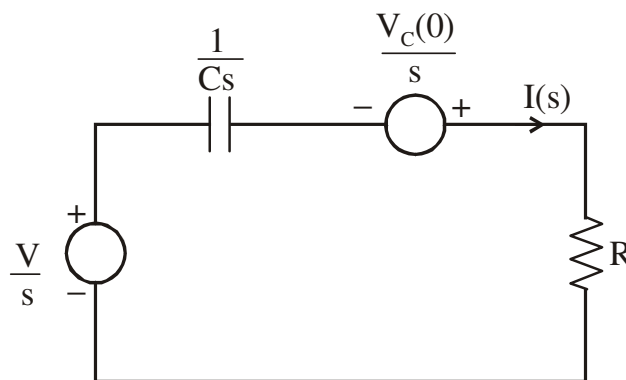

Fig. 5.31

We have to obtain an expression for capacitor voltage. It is done as follows:

$$I(S) = \frac{\frac{1}{Cs}(V + V_c(0))}{R + \frac{1}{Cs}}$$

$$I(S) = \frac{C(V + V_c(0))}{1 + RCs}$$

$$I(S) = \frac{(V + V_c(0))}{R \left(s + \frac{1}{RC} \right)}$$

Voltage across capacitor $V_c(s) = I(s) \frac{1}{Cs} - \frac{V_c(0)}{s}$

$$V_c(s) = \frac{1}{RCs} \frac{V + V_c(0)}{\left(s + \frac{1}{RC}\right)} - \frac{V_c(0)}{s}$$

$$V_c(s) = \frac{V + V_c(0)}{s} - \frac{V + V_c(0)}{\left(s + \frac{1}{RC}\right)} - \frac{V_c(0)}{s}$$

$$V_c(s) = \frac{V}{s} - \frac{V}{s + \frac{1}{RC}} - \frac{V_c(0)}{s + \frac{1}{RC}}$$

$$v_c(t) = V\left(1 - e^{-t/RC}\right) - V_c(0)e^{-t/RC}$$

In the given problem $V_c(0) = V$

Therefore $v_c(t) = V\left(1 - 2e^{-t/RC}\right)$

The waveform of $v_c(t)$ is shown in figure 5.32.

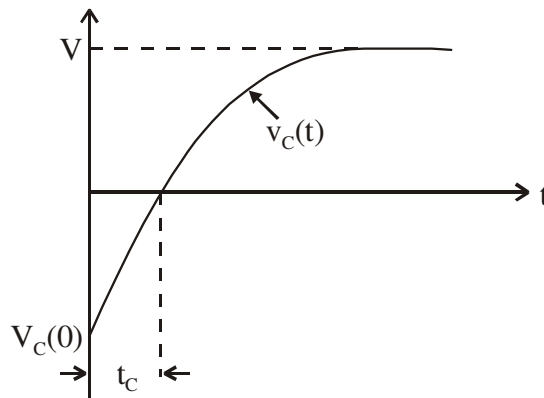

Fig. 5.32

At $t = t_c$, $v_c(t) = 0$

Therefore $0 = V\left(1 - 2e^{-t_c/RC}\right)$

$$1 = 2e^{-t_c/RC}$$

$$\frac{1}{2} = e^{-t_c/RC}$$

Taking natural logarithms

$$\log_e \left(\frac{1}{2} \right) = \frac{-t_c}{RC}$$

$$t_c = RC \ln(2)$$

$$t_c = 10 \times 10 \times 10^{-6} \ln(2)$$

$$t_c = 69.3 \mu \text{sec}.$$

Problem 5.11: In the commutation circuit shown in figure 5.33. $C = 20 \mu\text{F}$, the input voltage V varies between 180 and 220 V and the load current varies between 50 and 200 A. Determine the minimum and maximum values of available turn off time t_c .

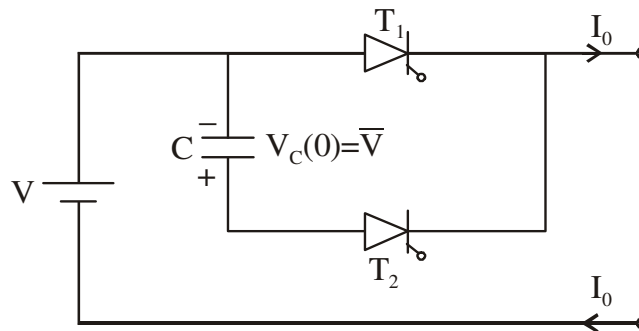

Fig. 5.33

Solution

It is given that V varies between 180 and 220 V and I_o varies between 50 and 200 A. The expression for available turn off time t_c is given by

$$t_c = \frac{CV}{I_o}$$

t_c is maximum when V is maximum and I_o is minimum.

Therefore
$$t_{c \max} = \frac{CV_{\max}}{I_{o \min}}$$

$$t_{c \max} = 20 \times 10^{-6} \times \frac{220}{50} = 88 \mu \text{sec}$$

and
$$t_{c\min} = \frac{CV_{\min}}{I_{O\max}}$$

$$t_{c\min} = 20 \times 10^{-6} \times \frac{180}{200} = 18 \mu \text{sec}$$

5.6 External Pulse Commutation (Class E Commutation)

Fig. 5.34: External Pulse Commutation

In this type of commutation an additional source is required to turn-off the conducting thyristor. Figure 5.34 shows a circuit for external pulse commutation. V_s is the main voltage source and V_{AUX} is the auxiliary supply. Assume thyristor T_1 is conducting and load R_L is connected across supply V_s . When thyristor T_3 is turned ON at $t = 0$, V_{AUX} , T_3 , L and C form an oscillatory circuit. Assuming capacitor is initially uncharged, capacitor C is now charged to a voltage $2V_{AUX}$ with upper plate positive at $t = \pi\sqrt{LC}$. When current through T_3 falls to zero, T_3 gets commutated. To turn-off the main thyristor T_1 , thyristor T_2 is turned ON. Then T_1 is subjected to a reverse voltage equal to $V_s - 2V_{AUX}$. This results in thyristor T_1 being turned-off. Once T_1 is off capacitor 'C' discharges through the load R_L .

Load Side Commutation

In load side commutation the discharging and recharging of capacitor takes place through the load. Hence to test the commutation circuit the load has to be connected. Examples of load side commutation are Resonant Pulse Commutation and Impulse Commutation.

Line Side Commutation

In this type of commutation the discharging and recharging of capacitor takes place through the supply.

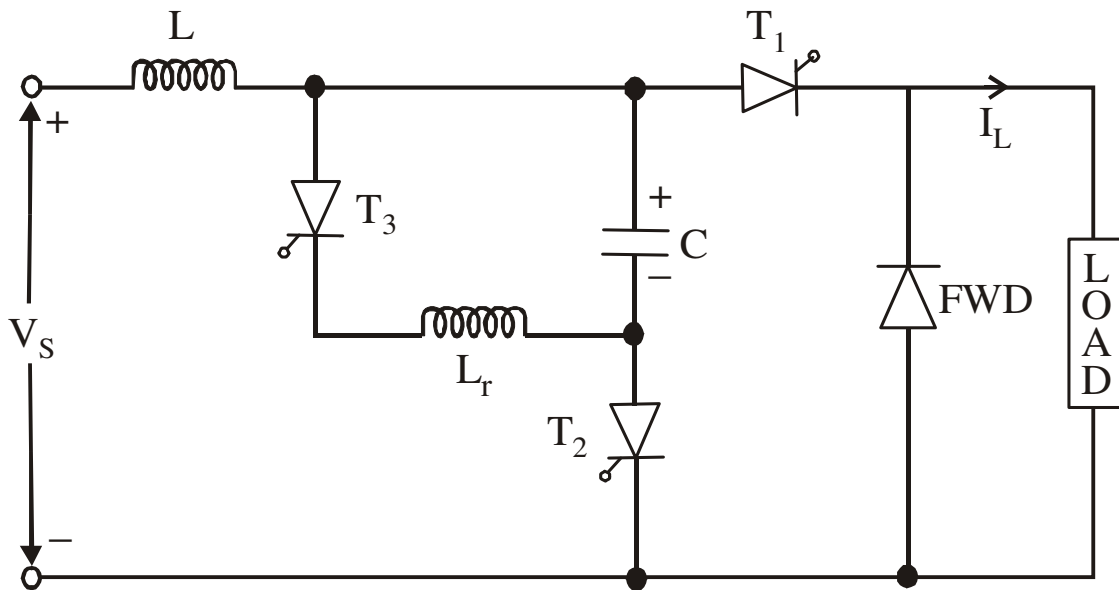

Fig.: 5.35 Line Side Commutation Circuit

Figure 5.35 shows line side commutation circuit. Thyristor T_2 is fired to charge the capacitor 'C'. When 'C' charges to a voltage of $2V$, T_2 is self commutated. To reverse the voltage of capacitor to $-2V$, thyristor T_3 is fired and T_3 commutates by itself. Assuming that T_1 is conducting and carries a load current I_L thyristor T_2 is fired to turn off T_1 . The turning ON of T_2 will result in forward biasing the diode (FWD) and applying a reverse voltage of $2V$ across T_1 . This turns off T_1 , thus the discharging and recharging of capacitor is done through the supply and the commutation circuit can be tested without load.

Recommended questions:

1. What are the two general types of commutation?
2. What is forced commutation and what are the types of forced commutation?
3. Explain in detail the difference between self and natural commutation.
4. What are the conditions to be satisfied for successful commutation of a thyristor
5. Explain the dynamic turn off characteristics of a thyristor clearly explaining the components of the turn off time.
6. What is the principle of self commutation?
7. What is the principle of impulse commutation?
8. What is the principle of resonant pulse commutation?
9. What is the principle of external pulse commutation?
10. What are the differences between voltage and current commutation?
11. What are the purposes of a commutation circuit?
12. Why should the available reverse bias time be greater than the turn off time of the Thyristor

What is the purpose of connecting an anti-parallel diode across the main thyristor with or

UNIT-4

Controlled Rectifiers

4.1 Line Commutated AC to DC converters

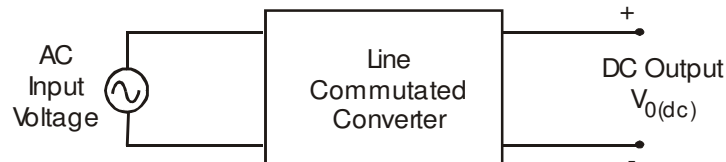

- Type of input: Fixed voltage, fixed frequency ac power supply.
- Type of output: Variable dc output voltage
- Type of commutation: Natural / AC line commutation

4.1.1 Different types of Line Commutated Converters

- AC to DC Converters (Phase controlled rectifiers)
- AC to AC converters (AC voltage controllers)
- AC to AC converters (Cyclo converters) at low output frequency

4.1.2 Differences Between Diode Rectifiers & Phase Controlled Rectifiers

- The diode rectifiers are referred to as uncontrolled rectifiers .
- The diode rectifiers give a fixed dc output voltage .
- Each diode conducts for one half cycle.
- Diode conduction angle = 180^0 or π radians.
- We cannot control the dc output voltage or the average dc load current in a diode rectifier circuit

Single phase half wave diode rectifier gives an

$$\text{Average dc output voltage } V_{O(dc)} = \frac{V_m}{\pi}$$

Single phase full wave diode rectifier gives an

$$\text{Average dc output voltage } V_{O(dc)} = \frac{2V_m}{\pi}$$

4.2 Applications of Phase Controlled Rectifiers

- DC motor control in steel mills, paper and textile mills employing dc motor drives.
- AC fed traction system using dc traction motor.
- Electro-chemical and electro-metallurgical processes.
- Magnet power supplies.

- Portable hand tool drives

4.3 Classification of Phase Controlled Rectifiers

- Single Phase Controlled Rectifiers.
- Three Phase Controlled Rectifiers

4.3.1 Different types of Single Phase Controlled Rectifiers.

- Half wave controlled rectifiers.
- Full wave controlled rectifiers.
- Using a center tapped transformer.
- Full wave bridge circuit.
- Semi converter.
- Full converter.

4.3.2 Different Types of Three Phase Controlled Rectifiers

- Half wave controlled rectifiers.
- Full wave controlled rectifiers.
- Semi converter (half controlled bridge converter).
- Full converter (fully controlled bridge converter).

4.4 Principle of Phase Controlled Rectifier Operation

Single Phase Half-Wave Thyristor Converter with a Resistive Load

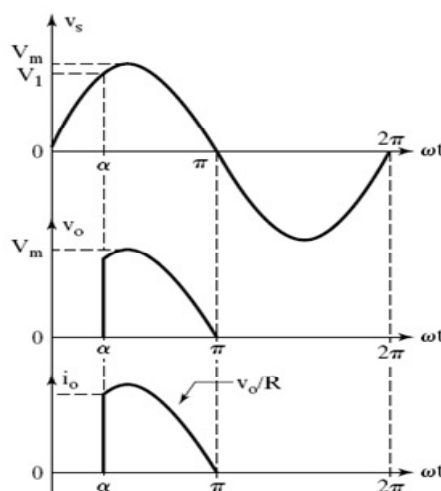
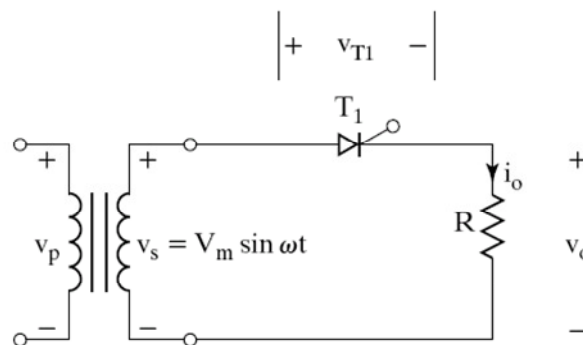

Equations:

$$v_s = V_m \sin \omega t = \text{i/p ac supply voltage}$$

$$V_m = \text{max. value of i/p ac supply voltage}$$

$$V_s = \frac{V_m}{\sqrt{2}} = \text{RMS value of i/p ac supply voltage}$$

$$v_o = v_L = \text{output voltage across the load}$$

When the thyristor is triggered at $\omega t = \alpha$

$$v_o = v_L = V_m \sin \omega t; \omega t = \alpha \text{ to } \pi$$

$$i_o = i_L = \frac{v_o}{R} = \text{Load current; } \omega t = \alpha \text{ to } \pi$$

$$i_o = i_L = \frac{V_m \sin \omega t}{R} = I_m \sin \omega t; \omega t = \alpha \text{ to } \pi$$

$$\text{Where } I_m = \frac{V_m}{R} = \text{max. value of load current}$$

4.4.1 To Derive an Expression for the Average (DC) Output Voltage across the Load

$$V_{O(dc)} = V_{dc} = \frac{1}{2\pi} \int_0^{2\pi} v_o \cdot d(\omega t);$$

$$v_o = V_m \sin \omega t \text{ for } \omega t = \alpha \text{ to } \pi$$

$$V_{O(dc)} = V_{dc} = \frac{1}{2\pi} \int_{\alpha}^{\pi} V_m \sin \omega t \cdot d(\omega t)$$

$$V_{O(dc)} = \frac{1}{2\pi} \int_{\alpha}^{\pi} V_m \sin \omega t \cdot d(\omega t)$$

$$V_{O(dc)} = \frac{V_m}{2\pi} \int_{\alpha}^{\pi} \sin \omega t \cdot d(\omega t)$$

$$V_{O(dc)} = \frac{V_m}{2\pi} \left[-\cos \omega t \Big|_{\alpha}^{\pi} \right]$$

$$V_{O(dc)} = \frac{V_m}{2\pi} [-\cos \pi + \cos \alpha]; \cos \pi = -1$$

$$V_{O(dc)} = \frac{V_m}{2\pi} [1 + \cos \alpha]; V_m = \sqrt{2}V_s$$

Maximum average (dc) o/p
voltage is obtained when $\alpha = 0$
and the maximum dc output voltage

$$V_{dc(\max)} = V_{dm} = \frac{V_m}{2\pi} (1 + \cos 0); \cos(0) = 1$$

$$\therefore V_{dc(\max)} = V_{dm} = \frac{V_m}{\pi}$$

$$V_{O(dc)} = \frac{V_m}{2\pi} [1 + \cos \alpha]; V_m = \sqrt{2}V_s$$

The average dc output voltage can be varied
by varying the trigger angle α from 0 to a
maximum of 180° (π radians)

We can plot the control characteristic

($V_{O(dc)}$ vs α) by using the equation for $V_{O(dc)}$

4.5 Control Characteristic of Single Phase Half Wave Phase Controlled Rectifier with Resistive Load

The average dc output voltage is given by the
expression

$$V_{O(dc)} = \frac{V_m}{2\pi} [1 + \cos \alpha]$$

We can obtain the control characteristic by
plotting the expression for the dc output
voltage as a function of trigger angle α

Trigger angle α in degrees	$V_{O(dc)}$	%
0	$V_{dm} = \frac{V_m}{\pi}$	100% V_{dm}
30°	$0.933 V_{dm}$	93.3 % V_{dm}
60°	$0.75 V_{dm}$	75 % V_{dm}
90°	$0.5 V_{dm}$	50 % V_{dm}
120°	$0.25 V_{dm}$	25 % V_{dm}
150°	$0.06698 V_{dm}$	6.69 % V_{dm}
180°	0	0

$$V_{dm} = \frac{V_m}{\pi} = V_{dc(\max)}$$

4.5.1 Control Characteristic

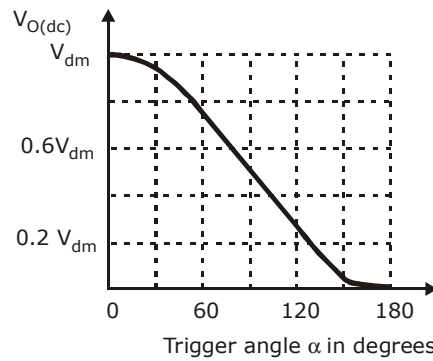

Normalizing the dc output voltage with respect to V_{dm} , the Normalized output voltage

$$V_n = \frac{V_{dc}}{V_{dm}} = \frac{\frac{V_m}{2\pi}(1 + \cos \alpha)}{\frac{V_m}{\pi}}$$

$$V_n = \frac{V_{dc}}{V_{dm}} = \frac{1}{2}(1 + \cos \alpha) = V_{dcn}$$

4.5.2 To Derive an Expression for the RMS Value of Output Voltage of a Single Phase Half Wave Controlled Rectifier with Resistive Load

The RMS output voltage is given by

$$V_{O(RMS)} = \left[\frac{1}{2\pi} \int_0^{2\pi} v_o^2 d(\omega t) \right]$$

Output voltage $v_o = V_m \sin \omega t$; for $\omega t = \alpha$ to π

$$V_{O(RMS)} = \left[\frac{1}{2\pi} \int_{\alpha}^{\pi} V_m^2 \sin^2 \omega t d(\omega t) \right]^{\frac{1}{2}}$$

By substituting $\sin^2 \omega t = \frac{1 - \cos 2\omega t}{2}$, we get

$$V_{O(RMS)} = \left[\frac{1}{2\pi} \int_{\alpha}^{\pi} V_m^2 \frac{(1 - \cos 2\omega t)}{2} d(\omega t) \right]^{\frac{1}{2}}$$

$$V_{O(RMS)} = \left[\frac{V_m^2}{4\pi} \int_{\alpha}^{\pi} (1 - \cos 2\omega t) d(\omega t) \right]^{\frac{1}{2}}$$

$$V_{O(RMS)} = \left[\frac{V_m^2}{4\pi} \left\{ \int_{\alpha}^{\pi} d(\omega t) - \int_{\alpha}^{\pi} \cos 2\omega t d(\omega t) \right\} \right]^{\frac{1}{2}}$$

$$V_{O(RMS)} = \frac{V_m}{2} \left[\frac{1}{\pi} \left\{ \left(\frac{\pi - \alpha}{1} \right) - \left(\frac{\sin 2\omega t}{2} \right) \right\} \right]^{\frac{1}{2}}$$

$$V_{O(RMS)} = \frac{V_m}{2} \left[\frac{1}{\pi} \left((\pi - \alpha) - \frac{(\sin 2\pi - \sin 2\alpha)}{2} \right) \right]^{\frac{1}{2}} ; \sin 2\pi = 0$$

4.5.3 Performance Parameters of Phase Controlled Rectifiers

Output dc power (avg. or dc o/p
power delivered to the load)

$$P_{O(dc)} = V_{O(dc)} \times I_{O(dc)} ; \text{ i.e., } P_{dc} = V_{dc} \times I_{dc}$$

Where

$$V_{O(dc)} = V_{dc} = \text{avg./dc value of o/p voltage.}$$

$$I_{O(dc)} = I_{dc} = \text{avg./dc value of o/p current}$$

Output ac power

$$P_{O(ac)} = V_{O(RMS)} \times I_{O(RMS)}$$

Efficiency of Rectification (Rectification Ratio)

$$\text{Efficiency } \eta = \frac{P_{O(dc)}}{P_{O(ac)}} ; \% \text{ Efficiency } \eta = \frac{P_{O(dc)}}{P_{O(ac)}} \times 100$$

The o/p voltage consists of two components

The dc component $V_{O(dc)}$

The ac /ripple component $V_{ac} = V_{r(rms)}$

Output ac power

$$P_{O(ac)} = V_{O(RMS)} \times I_{O(RMS)}$$

Efficiency of Rectification (Rectification Ratio)

$$\text{Efficiency } \eta = \frac{P_{O(dc)}}{P_{O(ac)}} ; \% \text{ Efficiency } \eta = \frac{P_{O(dc)}}{P_{O(ac)}} \times 100$$

The o/p voltage consists of two components

The dc component $V_{O(dc)}$

The ac /ripple component $V_{ac} = V_{r(rms)}$

4.5.4 The Ripple Factor (RF) w.r.t output voltage waveform

$$r_v = RF = \frac{V_{r(rms)}}{V_{O(dc)}} = \frac{V_{ac}}{V_{dc}}$$

$$r_v = \frac{\sqrt{V_{O(RMS)}^2 - V_{O(dc)}^2}}{V_{O(dc)}} = \sqrt{\left[\frac{V_{O(RMS)}}{V_{O(dc)}}\right]^2 - 1}$$

$$r_v = \sqrt{FF^2 - 1}$$

$$\text{Current Ripple Factor } r_i = \frac{I_{r(rms)}}{I_{O(dc)}} = \frac{I_{ac}}{I_{dc}}$$

$$\text{Where } I_{r(rms)} = I_{ac} = \sqrt{I_{O(RMS)}^2 - I_{O(dc)}^2}$$

$V_{r(pp)}$ = peak to peak ac ripple output voltage

$$V_{r(pp)} = V_{O(max)} - V_{O(min)}$$

$I_{r(pp)}$ = peak to peak ac ripple load current

$$I_{r(pp)} = I_{O(max)} - I_{O(min)}$$

Transformer Utilization Factor (TUF)

$$TUF = \frac{P_{O(dc)}}{V_s \times I_s}$$

Where

V_s = RMS supply (secondary) voltage

I_s = RMS supply (secondary) current

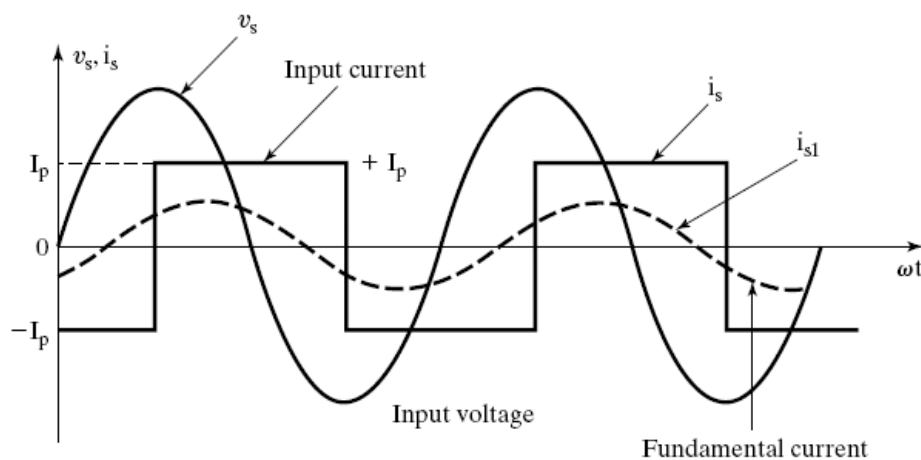

Where

v_s = Supply voltage at the transformer secondary side

i_s = i/p supply current

(transformer secondary winding current)

i_{s1} = Fundamental component of the i/p supply current

ϕ = Displacement angle (phase angle)

For an RL load

ϕ = Displacement angle = Load impedance angle

$$\therefore \phi = \tan^{-1} \left(\frac{\omega L}{R} \right) \text{ for an RL load}$$

Displacement Factor (DF) or

Fundamental Power Factor

$$DF = \cos \phi$$

Harmonic Factor (HF) or

Total Harmonic Distortion Factor ; THD

$$HF = \left[\frac{I_S^2 - I_{S1}^2}{I_{S1}^2} \right]^{\frac{1}{2}} = \left[\left(\frac{I_S}{I_{S1}} \right)^2 - 1 \right]^{\frac{1}{2}}$$

Where

I_S = RMS value of input supply current.

I_{S1} = RMS value of fundamental component of the i/p supply current.

Input Power Factor (PF)

$$PF = \frac{V_S I_{S1}}{V_S I_S} \cos \phi = \frac{I_{S1}}{I_S} \cos \phi$$

The Crest Factor (CF)

$$CF = \frac{I_{S(\text{peak})}}{I_S} = \frac{\text{Peak input supply current}}{\text{RMS input supply current}}$$

For an Ideal Controlled Rectifier

$$FF = 1; \eta = 100\% ; V_{ac} = V_{r(\text{rms})} = 0 ; TUF = 1;$$

$$RF = r_v = 0 ; HF = THD = 0; PF = DPF = 1$$

4.5.5 Single Phase Half Wave Controlled Rectifier with an RL Load

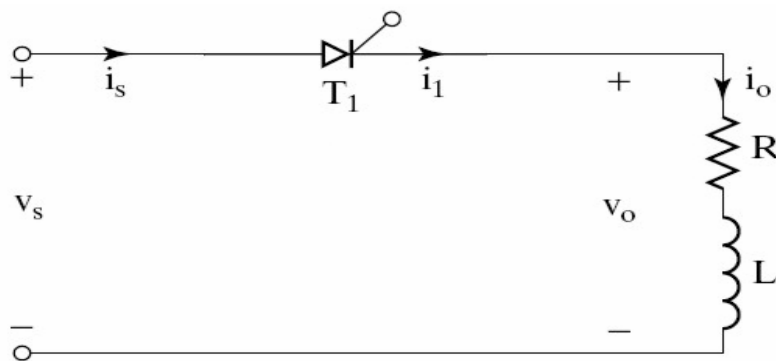

Input Supply Voltage (V_s) & Thyristor (Output) Current Waveforms

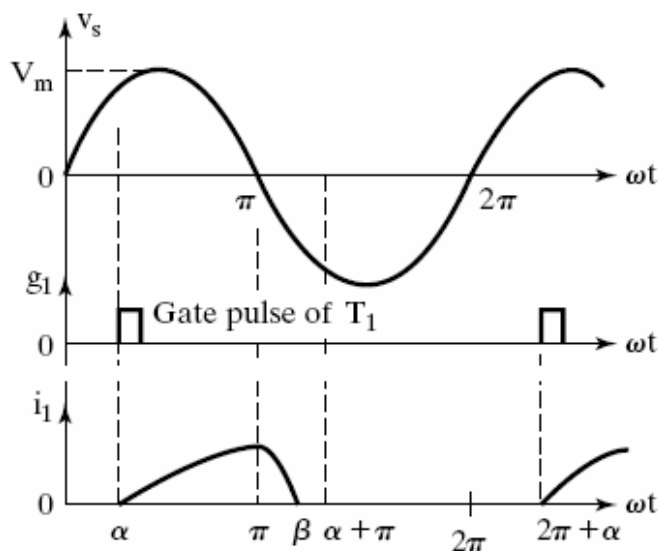

Output (Load) Voltage Waveform

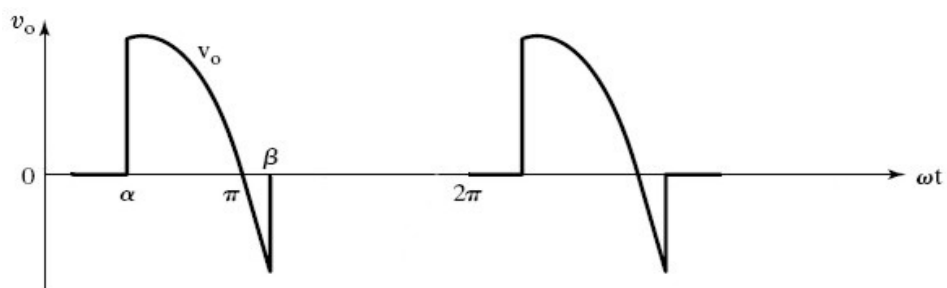

4.5.6 To derive an expression for the output (Load) current, during $\omega t = \alpha$ to β when

thyristor T_1 conducts

Assuming T_1 is triggered $\omega t = \alpha$,
we can write the equation,

$$L \left(\frac{di_o}{dt} \right) + Ri_o = V_m \sin \omega t ; \alpha \leq \omega t \leq \beta$$

General expression for the output current,

$$i_o = \frac{V_m}{Z} \sin(\omega t - \phi) + A_1 e^{\frac{-t}{\tau}}$$

$V_m = \sqrt{2}V_s =$ maximum supply voltage.

$Z = \sqrt{R^2 + (\omega L)^2} =$ Load impedance.

$\phi = \tan^{-1} \left(\frac{\omega L}{R} \right) =$ Load impedance angle.

$\tau = \frac{L}{R} =$ Load circuit time constant.

\therefore general expression for the output load current

$$i_o = \frac{V_m}{Z} \sin(\omega t - \phi) + A_1 e^{\frac{-R}{L}t}$$

Constant A_1 is calculated from

initial condition $i_o = 0$ at $\omega t = \alpha$; $t = \left(\frac{\alpha}{\omega} \right)$

$$i_o = 0 = \frac{V_m}{Z} \sin(\alpha - \phi) + A_1 e^{\frac{-R}{L}t}$$

$$\therefore A_1 e^{\frac{-R}{L}t} = \frac{-V_m}{Z} \sin(\alpha - \phi)$$

We get the value of constant A_1 as

$$A_1 = e^{\frac{R(\alpha)}{\omega L}} \left[\frac{-V_m}{Z} \sin(\alpha - \phi) \right]$$

Substituting the value of constant A_1 in the general expression for i_o

$$i_o = \frac{V_m}{Z} \sin(\omega t - \phi) + e^{\frac{-R}{\omega L}(\omega t - \alpha)} \left[\frac{-V_m}{Z} \sin(\alpha - \phi) \right]$$

\therefore we obtain the final expression for the inductive load current

$$i_o = \frac{V_m}{Z} \left[\sin(\omega t - \phi) - \sin(\alpha - \phi) e^{\frac{-R}{\omega L}(\omega t - \alpha)} \right];$$

Where $\alpha \leq \omega t \leq \beta$

Extinction angle β can be calculated by using the condition that $i_o = 0$ at $\omega t = \beta$

$$i_o = \frac{V_m}{Z} \left[\sin(\omega t - \phi) - \sin(\alpha - \phi) e^{\frac{-R}{\omega L}(\omega t - \alpha)} \right] = 0$$

$$\therefore \sin(\beta - \phi) = e^{\frac{-R}{\omega L}(\beta - \alpha)} \times \sin(\alpha - \phi)$$

β can be calculated by solving the above eqn.

4.5.7 To Derive an Expression for Average (DC) Load Voltage of a Single Half Wave Controlled Rectifier with RL Load

$$V_{O(dc)} = V_L = \frac{1}{2\pi} \int_0^{2\pi} v_o \cdot d(\omega t)$$

$$V_{O(dc)} = V_L = \frac{1}{2\pi} \left[\int_0^{\alpha} v_o \cdot d(\omega t) + \int_{\alpha}^{\beta} v_o \cdot d(\omega t) + \int_{\beta}^{2\pi} v_o \cdot d(\omega t) \right]$$

$v_o = 0$ for $\omega t = 0$ to α & for $\omega t = \beta$ to 2π

$$\therefore V_{O(dc)} = V_L = \frac{1}{2\pi} \left[\int_{\alpha}^{\beta} v_o \cdot d(\omega t) \right];$$

$v_o = V_m \sin \omega t$ for $\omega t = \alpha$ to β

$$V_{O(dc)} = V_L = \frac{1}{2\pi} \left[\int_{\alpha}^{\beta} V_m \sin \omega t \cdot d(\omega t) \right]$$

$$V_{O(dc)} = V_L = \frac{V_m}{2\pi} \left[-\cos \omega t \right]_{\alpha}^{\beta}$$

$$V_{O(dc)} = V_L = \frac{V_m}{2\pi} (\cos \alpha - \cos \beta)$$

$$\therefore V_{O(dc)} = V_L = \frac{V_m}{2\pi} (\cos \alpha - \cos \beta)$$

Effect of Load Inductance on the Output

During the period $\omega t = \pi$ to β the instantaneous output voltage is negative and this reduces the average or the dc output voltage when compared to a purely resistive load.

4.5.8 Average DC Load Current

$$I_{O(dc)} = I_{L(Avg)} = \frac{V_{O(dc)}}{R_L} = \frac{V_m}{2\pi R_L} (\cos \alpha - \cos \beta)$$

4.5.9 Single Phase Half Wave Controlled Rectifier with RL Load & Free Wheeling Diode

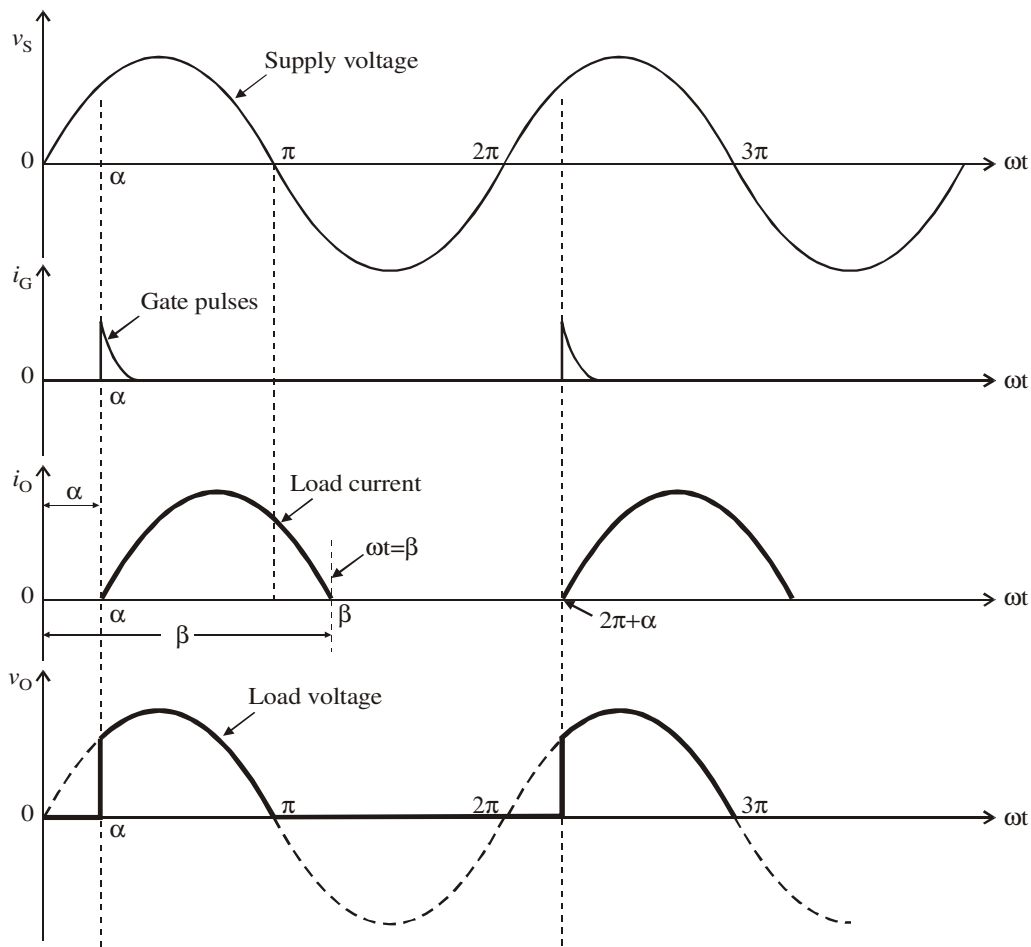
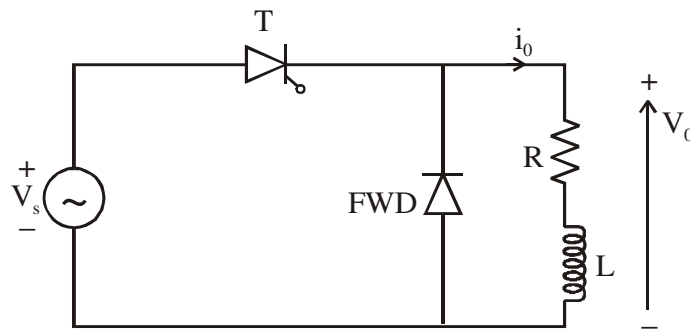

The average output voltage

$$V_{dc} = \frac{V_m}{2\pi} [1 + \cos \alpha]$$

which is the same as that of a purely resistive load.

The following points are to be noted

For low value of inductance, the load current tends to become discontinuous.

During the period α to π

the load current is carried by the SCR.

During the period π to β load current is carried by the free wheeling diode.

The value of β depends on the value of R and L and the forward resistance of the FWD.

For Large Load Inductance the load current does not reach zero, & we obtain continuous load current.

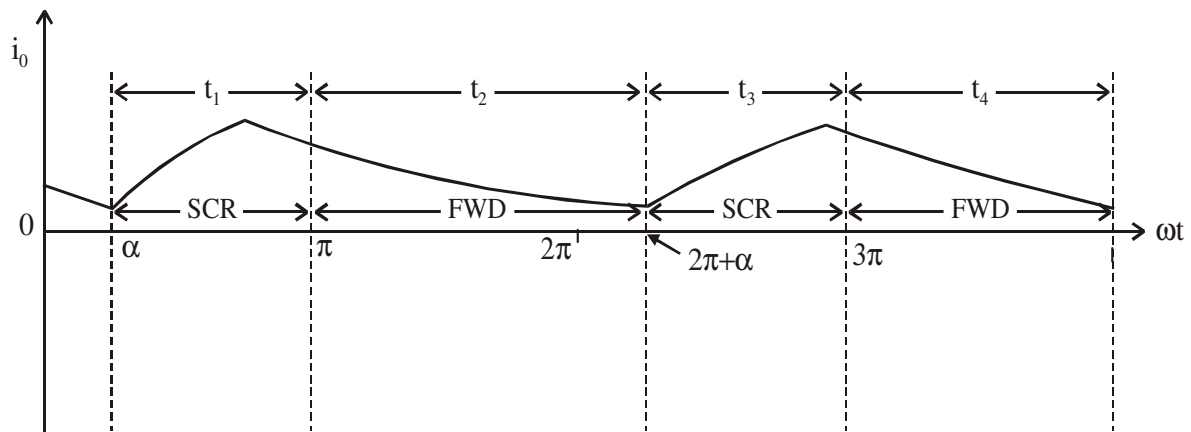

4.6 Single Phase Full Wave Controlled Rectifier Using A Center Tapped Transformer

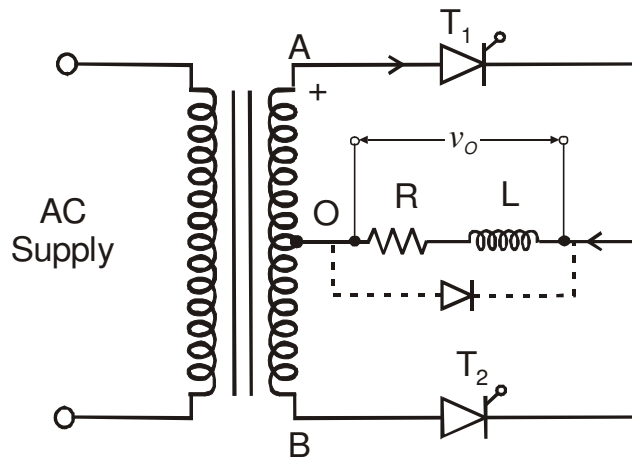

4.6.1 Discontinuous Load Current Operation without FWD for $\pi < \beta < (\pi + \alpha)$

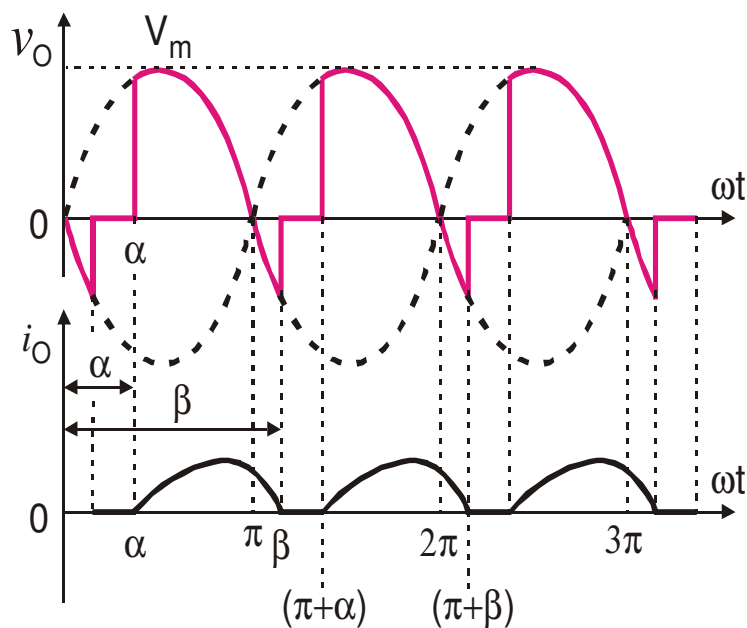

(i) To derive an expression for the output (load) current, during $\omega t = \alpha$ to β when thyristor T_1 conducts

Assuming T_1 is triggered $\omega t = \alpha$,
we can write the equation,

$$L \left(\frac{di_o}{dt} \right) + Ri_o = V_m \sin \omega t ; \alpha \leq \omega t \leq \beta$$

General expression for the output current,

$$i_o = \frac{V_m}{Z} \sin(\omega t - \phi) + A_1 e^{\frac{-t}{\tau}}$$

Constant A_1 is calculated from

initial condition $i_o = 0$ at $\omega t = \alpha$; $t = \left(\frac{\alpha}{\omega}\right)$

$$i_o = 0 = \frac{V_m}{Z} \sin(\alpha - \phi) + A_1 e^{\frac{-R}{L} t}$$

$$\therefore A_1 e^{\frac{-R}{L} t} = \frac{-V_m}{Z} \sin(\alpha - \phi)$$

We get the value of constant A_1 as

$$A_1 = e^{\frac{R(\alpha)}{\omega L}} \left[\frac{-V_m}{Z} \sin(\alpha - \phi) \right]$$

$V_m = \sqrt{2}V_s =$ maximum supply voltage.

$Z = \sqrt{R^2 + (\omega L)^2} =$ Load impedance.

$\phi = \tan^{-1}\left(\frac{\omega L}{R}\right) =$ Load impedance angle.

$\tau = \frac{L}{R} =$ Load circuit time constant.

\therefore general expression for the output load current

$$i_o = \frac{V_m}{Z} \sin(\omega t - \phi) + A_1 e^{\frac{-R}{L} t}$$

Substituting the value of constant A_1 in the general expression for i_o

$$i_o = \frac{V_m}{Z} \sin(\omega t - \phi) + e^{\frac{-R}{\omega L}(\omega t - \alpha)} \left[\frac{-V_m}{Z} \sin(\alpha - \phi) \right]$$

\therefore we obtain the final expression for the inductive load current

$$i_o = \frac{V_m}{Z} \left[\sin(\omega t - \phi) - \sin(\alpha - \phi) e^{\frac{-R}{\omega L}(\omega t - \alpha)} \right];$$

Where $\alpha \leq \omega t \leq \beta$

Extinction angle β can be calculated by using the condition that $i_o = 0$ at $\omega t = \beta$

$$i_o = \frac{V_m}{Z} \left[\sin(\omega t - \phi) - \sin(\alpha - \phi) e^{\frac{-R}{\omega L}(\omega t - \alpha)} \right] = 0$$

$$\therefore \sin(\beta - \phi) = e^{\frac{-R}{\omega L}(\beta - \alpha)} \times \sin(\alpha - \phi)$$

β can be calculated by solving the above eqn.

(ii) To Derive an Expression for the DC Output Voltage of A Single Phase Full Wave Controlled Rectifier with RL Load (*Without FWD*)

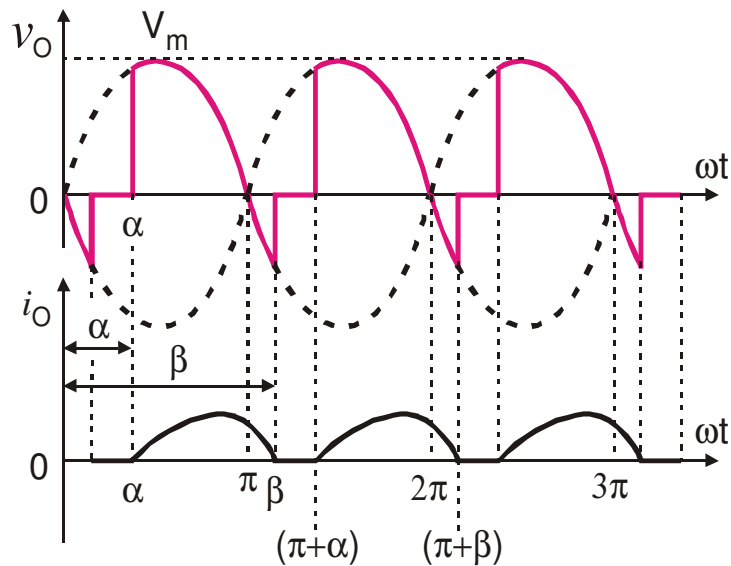

$$V_{O(dc)} = V_{dc} = \frac{1}{\pi} \int_{\omega t = \alpha}^{\beta} v_o \cdot d(\omega t)$$

$$V_{O(dc)} = V_{dc} = \frac{1}{\pi} \left[\int_{\alpha}^{\beta} V_m \sin \omega t \cdot d(\omega t) \right]$$

$$V_{O(dc)} = V_{dc} = \frac{V_m}{\pi} \left[-\cos \omega t \Big|_{\alpha}^{\beta} \right]$$

$$V_{O(dc)} = V_{dc} = \frac{V_m}{\pi} (\cos \alpha - \cos \beta)$$

When the load inductance is negligible (i.e., $L \approx 0$)

Extinction angle $\beta = \pi$ radians

Hence the average or dc output voltage for R load

$$V_{O(dc)} = \frac{V_m}{\pi} (\cos \alpha - \cos \pi)$$

$$V_{O(dc)} = \frac{V_m}{\pi} (\cos \alpha - (-1))$$

$$V_{O(dc)} = \frac{V_m}{\pi} (1 + \cos \alpha); \text{ for R load, when } \beta = \pi$$

(iii) To calculate the RMS output voltage we use the expression

$$V_{O(RMS)} = \sqrt{\frac{1}{\pi} \left[\int_{\alpha}^{\beta} V_m^2 \sin^2 \omega t \cdot d(\omega t) \right]}$$

(iv) Discontinuous Load Current Operation with FWD

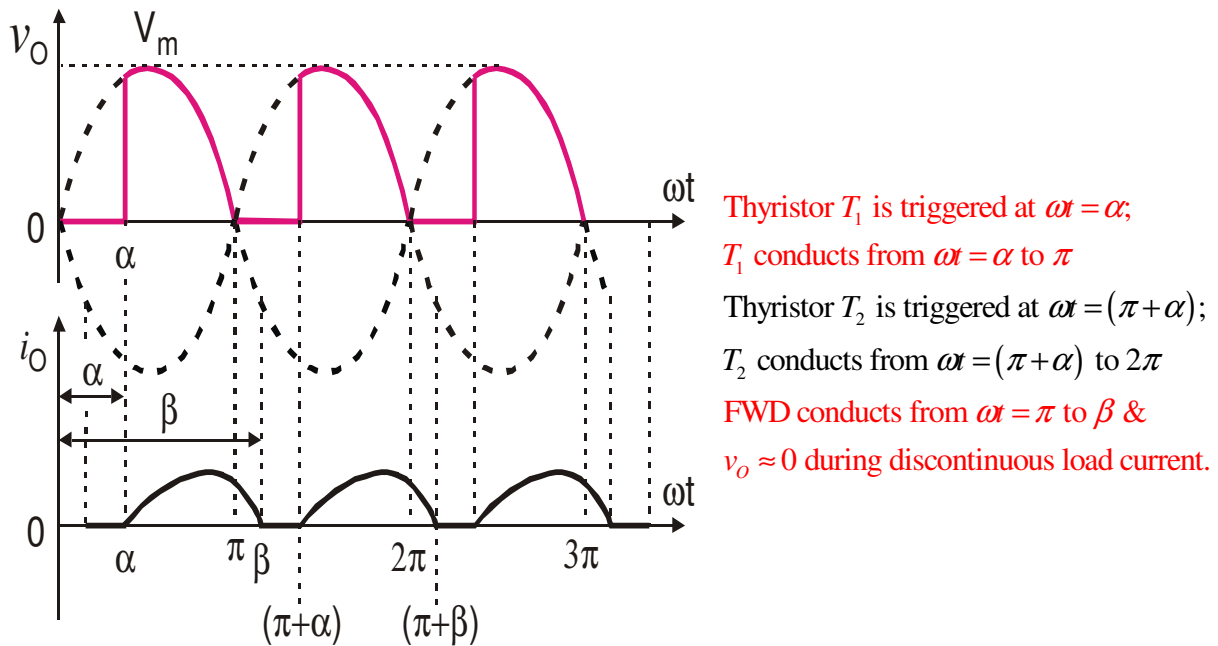

(v) To Derive an Expression for the DC Output Voltage for a Single Phase Full Wave Controlled Rectifier with RL Load & FWD

$$V_{O(dc)} = V_{dc} = \frac{1}{\pi} \int_{\omega t=0}^{\pi} v_o \cdot d(\omega t)$$

$$\therefore V_{O(dc)} = V_{dc} = \frac{1}{\pi} \int_{\alpha}^{\pi} V_m \sin \omega t \cdot d(\omega t)$$

$$V_{O(dc)} = V_{dc} = \frac{V_m}{\pi} \left[-\cos \omega t \right]_{\alpha}^{\pi}$$

$$V_{O(dc)} = V_{dc} = \frac{V_m}{\pi} [-\cos \pi + \cos \alpha] \quad ; \quad \cos \pi = -1$$

$$\therefore V_{O(dc)} = V_{dc} = \frac{V_m}{\pi} (1 + \cos \alpha)$$

- The load current is discontinuous for low values of load inductance and for large values of trigger angles.
- For large values of load inductance the load current flows continuously without falling to zero.
- Generally the load current is continuous for large load inductance and for low trigger angles.

4.6.2 Continuous Load Current Operation (Without FWD)

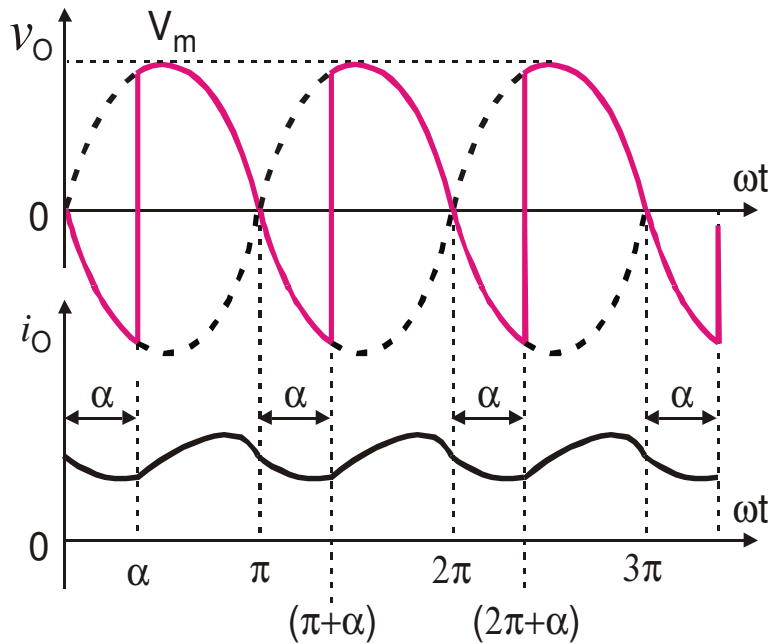

(i) To Derive an Expression for Average / DC Output Voltage of Single Phase Full Wave Controlled Rectifier for Continuous Current Operation without FWD

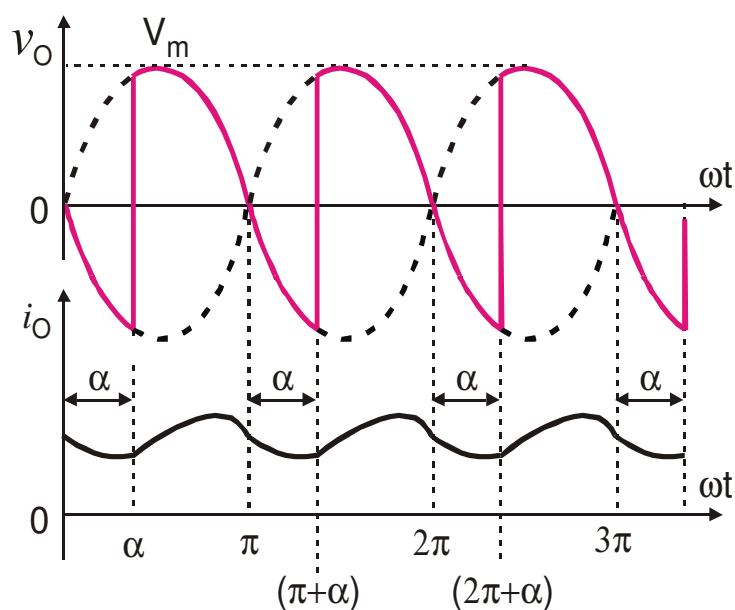

$$V_{O(dc)} = V_{dc} = \frac{1}{\pi} \int_{\omega t = \alpha}^{(\pi + \alpha)} v_o \cdot d(\omega t)$$

$$V_{O(dc)} = V_{dc} = \frac{1}{\pi} \left[\int_{\alpha}^{(\pi + \alpha)} V_m \sin \omega t \cdot d(\omega t) \right]$$

$$V_{O(dc)} = V_{dc} = \frac{V_m}{\pi} \left[-\cos \omega t \Big|_{\alpha}^{(\pi + \alpha)} \right]$$

$$V_{O(dc)} = V_{dc}$$

$$= \frac{V_m}{\pi} [\cos \alpha - \cos(\pi + \alpha)] ;$$

$$\cos(\pi + \alpha) = -\cos \alpha$$

$$V_{O(dc)} = V_{dc} = \frac{V_m}{\pi} [\cos \alpha + \cos \alpha]$$

$$\therefore V_{O(dc)} = V_{dc} = \frac{2V_m}{\pi} \cos \alpha$$

- By plotting $VO(dc)$ versus α , we obtain the control characteristic of a single phase full wave controlled rectifier with RL load for continuous load current operation without FWD

Trigger angle α in degrees	$V_{O(dc)}$	Remarks
0	$V_{dm} = \left(\frac{2V_m}{\pi} \right)$	Maximum dc output voltage $V_{dc(max)} = V_{dm} = \left(\frac{2V_m}{\pi} \right)$
30°	$0.866 V_{dm}$	$V_{dc} = V_{dm} \times \cos \alpha$
60°	$0.5 V_{dm}$	
90°	$0 V_{dm}$	
120°	$-0.5 V_{dm}$	
150°	$-0.866 V_{dm}$	
180°	$-V_{dm} = -\left(\frac{2V_m}{\pi} \right)$	

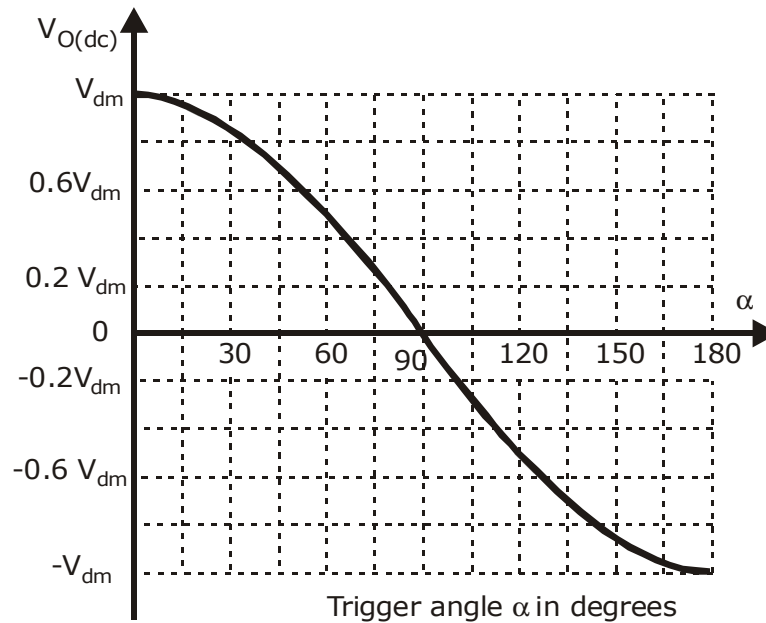

By varying the trigger angle we can vary the output dc voltage across the load. Hence we can control the dc output power flow to the load.

For trigger angle α , 0 to 90° (i.e., $0 \leq \alpha \leq 90^\circ$);

$\cos \alpha$ is positive and hence V_{dc} is positive

V_{dc} & I_{dc} are positive ; $P_{dc} = (V_{dc} \times I_{dc})$ is positive

Converter operates as a **Controlled Rectifier**.

Power flow is from the ac source to the load.

For trigger angle α , 90° to 180°

(i.e., $90^\circ \leq \alpha \leq 180^\circ$),

$\cos \alpha$ is negative and hence

V_{dc} is negative; I_{dc} is positive ;

$P_{dc} = (V_{dc} \times I_{dc})$ is negative.

In this case the converter operates

as a **Line Commutated Inverter**.

Power flows from the load ckt. to the i/p ac source.

The inductive load energy is fed back to the

i/p source.

Drawbacks of Full Wave Controlled Rectifier with Centre Tapped Transformer

- We require a centre tapped transformer which is quite heavier and bulky.
- Cost of the transformer is higher for the required dc output voltage & output power.
- Hence full wave bridge converters are preferred.

4.7 Single Phase Full Wave Bridge Controlled Rectifier

2 types of FW Bridge Controlled Rectifiers are

- Half Controlled Bridge Converter (Semi-Converter)
- Fully Controlled Bridge Converter (Full Converter)

The bridge full wave controlled rectifier does not require a centre tapped transformer

4.7.1 Single Phase Full Wave Half Controlled Bridge Converter (Single Phase Semi Converter)

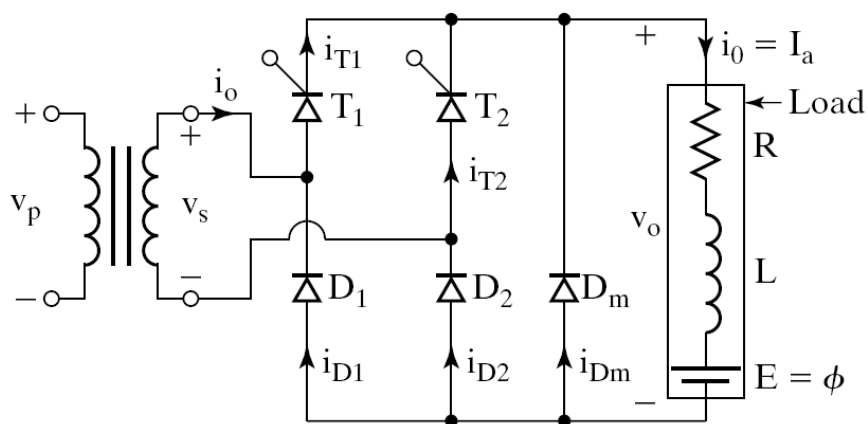

Trigger Pattern of Thyristors

Thyristor T_1 is triggered at

$$\omega t = \alpha, \text{ at } \omega t = (2\pi + \alpha), \dots$$

Thyristor T_2 is triggered at

$$\omega t = (\pi + \alpha), \text{ at } \omega t = (3\pi + \alpha), \dots$$

The time delay between the gating

signals of T_1 & $T_2 = \pi$ radians or 180°

Waveforms of single phase semi-converter with general load & FWD for $\alpha > 90^\circ$

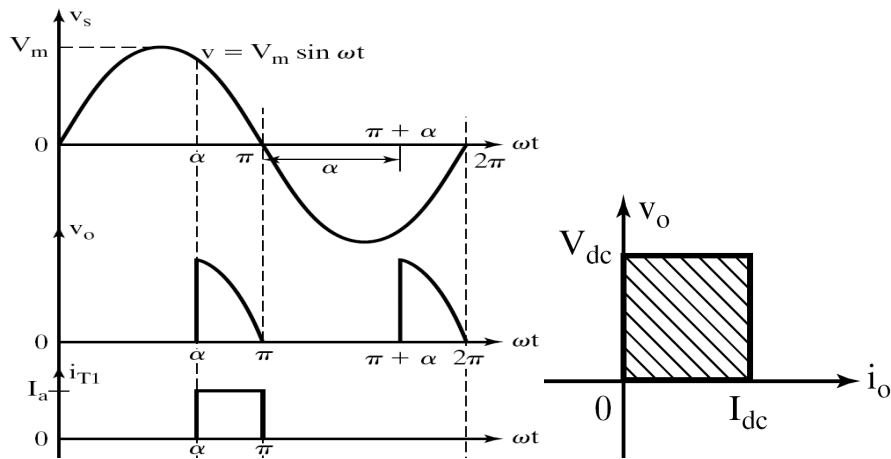

Single Quadrant Operation

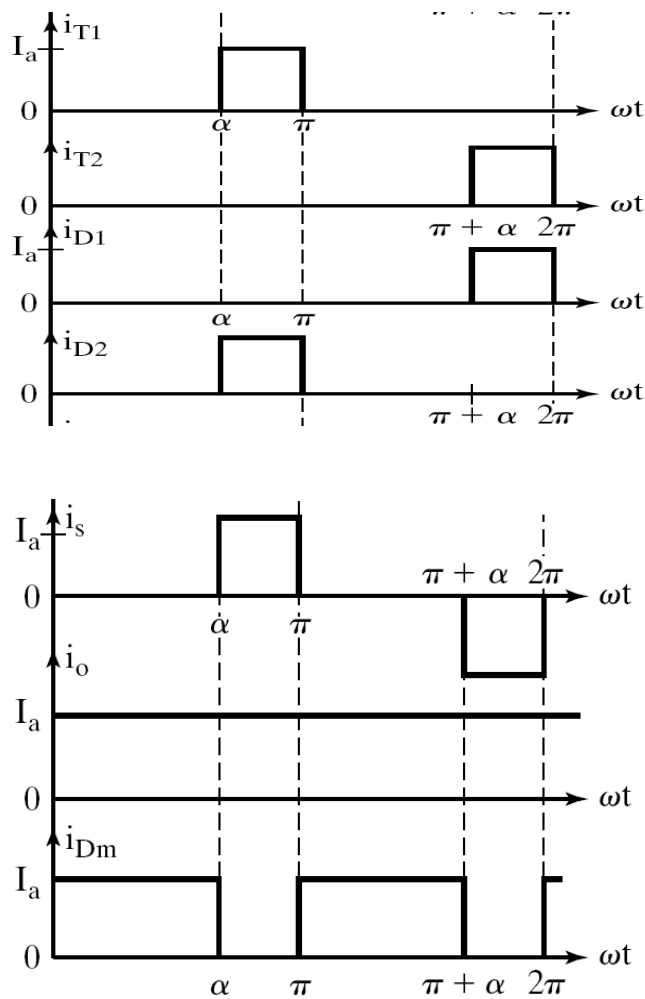

Thyristor T_1 and D_1 conduct from $\omega t = \alpha$ to π
 Thyristor T_2 and D_2 conduct from $\omega t = (\pi + \alpha)$ to 2π
 FWD conducts during $\omega t = 0$ to α , π to $(\pi + \alpha)$,

Load Voltage & Load Current Waveform of Single Phase Semi Converter for $\alpha < 90^\circ$ & Continuous load current operation

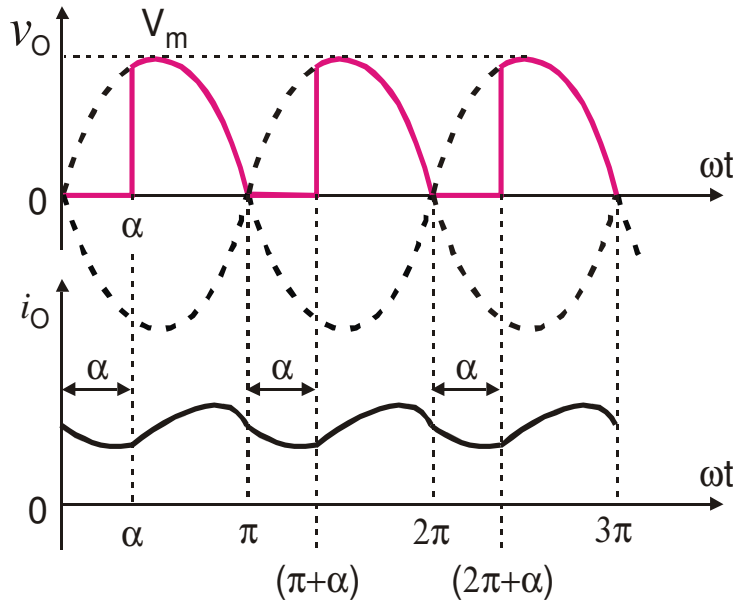

(i) To Derive an Expression for The DC Output Voltage of A Single Phase Semi Converter with R, L, & E Load & FWD For Continuous, Ripple Free Load Current Operation

$$V_{O(dc)} = V_{dc} = \frac{1}{\pi} \int_{\alpha}^{\pi} v_o \cdot d(\omega t)$$

$$\therefore V_{O(dc)} = V_{dc} = \frac{1}{\pi} \int_{\alpha}^{\pi} V_m \sin \omega t \cdot d(\omega t)$$

$$V_{O(dc)} = V_{dc} = \frac{V_m}{\pi} \left[-\cos \omega t \Big|_{\alpha}^{\pi} \right]$$

$$V_{O(dc)} = V_{dc} = \frac{V_m}{\pi} [-\cos \pi + \cos \alpha] \quad ; \quad \cos \pi = -1$$

$$\therefore V_{O(dc)} = V_{dc} = \frac{V_m}{\pi} (1 + \cos \alpha)$$

V_{dc} can be varied from a max.

value of $\frac{2V_m}{\pi}$ to 0 by varying α from 0 to π .

For $\alpha = 0$, The max. dc o/p voltage obtained is

$$V_{dc(\max)} = V_{dm} = \frac{2V_m}{\pi}$$

Normalized dc o/p voltage is

$$V_{dcn} = V_n = \frac{V_{dc}}{V_{dn}} = \frac{\frac{V_m}{\pi}(1 + \cos \alpha)}{\left(\frac{2V_m}{\pi}\right)} = \frac{1}{2}(1 + \cos \alpha)$$

(ii) RMS O/P Voltage $V_{O(RMS)}$

$$V_{O(RMS)} = \left[\frac{2}{2\pi} \int_{\alpha}^{\pi} V_m^2 \sin^2 \omega t \cdot d(\omega t) \right]^{\frac{1}{2}}$$

$$V_{O(RMS)} = \left[\frac{V_m^2}{2\pi} \int_{\alpha}^{\pi} (1 - \cos 2\omega t) \cdot d(\omega t) \right]^{\frac{1}{2}}$$

$$V_{O(RMS)} = \frac{V_m}{\sqrt{2}} \left[\frac{1}{\pi} \left(\pi - \alpha + \frac{\sin 2\alpha}{2} \right) \right]^{\frac{1}{2}}$$

4.7.2 Single Phase Full Wave Full Converter (Fully Controlled Bridge Converter) With R, L, & E Load

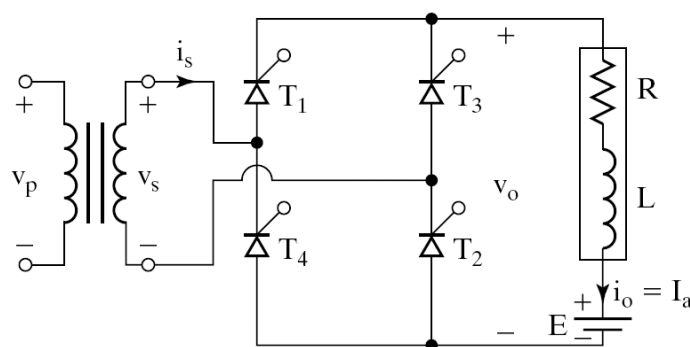

Waveforms of Single Phase Full Converter Assuming Continuous (Constant Load Current) & Ripple Free Load Current.

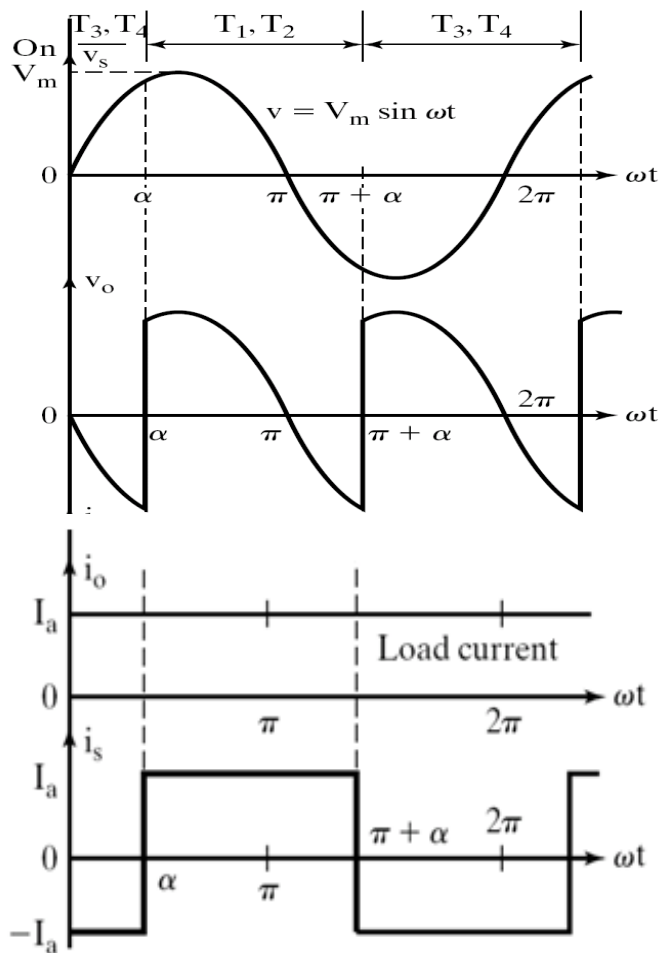

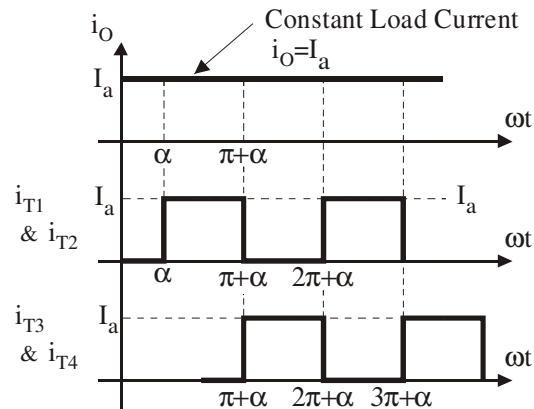

(i) To Derive An Expression For The Average DC Output Voltage of a Single Phase Full Converter assuming Continuous & Constant Load Current

The average dc output voltage can be determined by using the expression

$$V_{O(dc)} = V_{dc} = \frac{1}{2\pi} \left[\int_0^{2\pi} v_o \cdot d(\omega t) \right];$$

The o/p voltage waveform consists of two o/p pulses during the input supply time period of 0 to 2π radians. Hence the Average or dc o/p voltage can be calculated as

$$V_{O(dc)} = V_{dc} = \frac{2}{2\pi} \left[\int_{\alpha}^{\pi+\alpha} V_m \sin \omega t \cdot d(\omega t) \right]$$

$$V_{O(dc)} = V_{dc} = \frac{2V_m}{2\pi} [-\cos \omega t]_{\alpha}^{\pi+\alpha}$$

$$V_{O(dc)} = V_{dc} = \frac{2V_m}{\pi} \cos \alpha$$

Maximum average dc output voltage is calculated for a trigger angle $\alpha = 0^\circ$ and is obtained as

$$V_{dc(max)} = V_{dm} = \frac{2V_m}{\pi} \times \cos(0) = \frac{2V_m}{\pi}$$

$$\therefore V_{dc(max)} = V_{dm} = \frac{2V_m}{\pi}$$

The normalized average output voltage is given by

$$V_{dcn} = V_n = \frac{V_{O(dc)}}{V_{dc(max)}} = \frac{V_{dc}}{V_{dm}}$$

$$\therefore V_{dcn} = V_n = \frac{\frac{2V_m}{\pi} \cos \alpha}{\frac{2V_m}{\pi}} = \cos \alpha$$

By plotting $V_{O(dc)}$ versus α , we obtain the control characteristic of a single phase full wave fully controlled bridge converter (single phase full converter) for constant & continuous load current operation.

To plot the control characteristic of a Single Phase Full Converter for constant & continuous load current operation. We use the equation for the average/ dc output voltage

$$V_{O(dc)} = V_{dc} = \frac{2V_m}{\pi} \cos \alpha$$

Trigger angle α in degrees	$V_{O(dc)}$	Remarks
0	$V_{dm} = \left(\frac{2V_m}{\pi}\right)$	Maximum dc output voltage $V_{dc(max)} = V_{dm} = \left(\frac{2V_m}{\pi}\right)$
30°	0.866 V_{dm}	
60°	0.5 V_{dm}	
90°	0 V_{dm}	
120°	-0.5 V_{dm}	
150°	-0.866 V_{dm}	
180°	$-V_{dm} = -\left(\frac{2V_m}{\pi}\right)$	

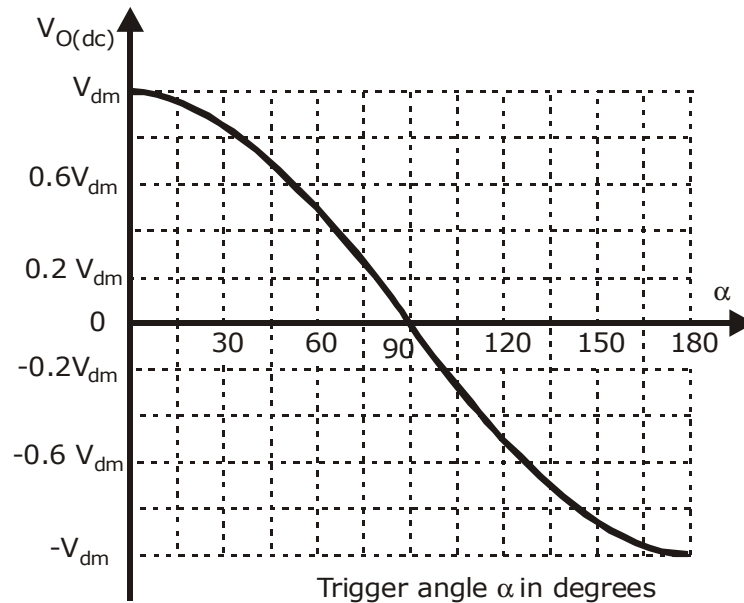

- During the period from $\omega t = \alpha$ to π the input voltage v_S and the input current i_S are both positive and the power flows from the supply to the load.
- The converter is said to be operated in the rectification mode Controlled Rectifier Operation for $0 < \alpha < 90^\circ$
- During the period from $\omega t = \pi$ to $(\pi + \alpha)$, the input voltage v_S is negative and the input current i_S is positive and the output power becomes negative and there will be reverse power flow from the load circuit to the supply.
- The converter is said to be operated in the inversion mode.

Line Commutated Inverter Operation for $90^\circ < \alpha < 180^\circ$

Two Quadrant Operation of a Single Phase Full Converter

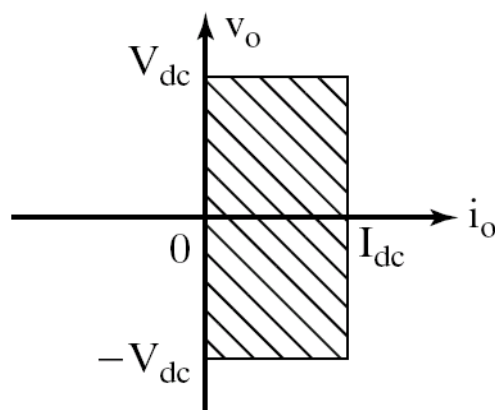

(ii) To Derive an Expression for the RMS Value of the Output Voltage

The rms value of the output voltage is calculated as

$$V_{O(RMS)} = \sqrt{\frac{1}{2\pi} \left[\int_0^{2\pi} v_o^2 \cdot d(\omega t) \right]}$$

The single phase full converter gives two output voltage pulses during the input supply time period and hence the single phase full converter is referred to as a two pulse converter. The rms output voltage can be calculated as

$$V_{O(RMS)} = \sqrt{\frac{2}{2\pi} \left[\int_{\alpha}^{\pi+\alpha} v_o^2 \cdot d(\omega t) \right]}$$

The single phase full converter gives two output voltage pulses during the input supply time period and hence the single phase full converter is referred to as a two pulse converter. The rms output voltage can be calculated as

$$V_{O(RMS)} = \sqrt{\frac{2}{2\pi} \left[\int_{\alpha}^{\pi+\alpha} v_o^2 \cdot d(\omega t) \right]}$$

$$V_{O(RMS)} = \sqrt{\frac{1}{\pi} \left[\int_{\alpha}^{\pi+\alpha} V_m^2 \sin^2 \omega t \cdot d(\omega t) \right]}$$

$$V_{O(RMS)} = \sqrt{\frac{V_m^2}{\pi} \left[\int_{\alpha}^{\pi+\alpha} \sin^2 \omega t \cdot d(\omega t) \right]}$$

$$V_{O(RMS)} = \sqrt{\frac{V_m^2}{\pi} \left[\int_{\alpha}^{\pi+\alpha} \frac{(1 - \cos 2\omega t)}{2} \cdot d(\omega t) \right]}$$

$$V_{O(RMS)} = \sqrt{\frac{V_m^2}{2\pi} \left[\int_{\alpha}^{\pi+\alpha} d(\omega t) - \int_{\alpha}^{\pi+\alpha} \cos 2\omega t \cdot d(\omega t) \right]}$$

$$V_{O(RMS)} = \sqrt{\frac{1}{\pi} \left[\int_{\alpha}^{\pi+\alpha} V_m^2 \sin^2 \omega t \cdot d(\omega t) \right]}$$

$$V_{O(RMS)} = \sqrt{\frac{V_m^2}{\pi} \left[\int_{\alpha}^{\pi+\alpha} \sin^2 \omega t \cdot d(\omega t) \right]}$$

$$V_{O(RMS)} = \sqrt{\frac{V_m^2}{\pi} \left[\int_{\alpha}^{\pi+\alpha} \frac{(1 - \cos 2\omega t)}{2} \cdot d(\omega t) \right]}$$

$$V_{O(RMS)} = \sqrt{\frac{V_m^2}{2\pi} \left[\int_{\alpha}^{\pi+\alpha} d(\omega t) - \int_{\alpha}^{\pi+\alpha} \cos 2\omega t \cdot d(\omega t) \right]}$$

$$V_{O(RMS)} = \sqrt{\frac{V_m^2}{2\pi} \left[\left(\omega t \right) \Big|_{\alpha}^{\pi+\alpha} - \left(\frac{\sin 2\omega t}{2} \right) \Big|_{\alpha}^{\pi+\alpha} \right]}$$

$$V_{O(RMS)} = \sqrt{\frac{V_m^2}{2\pi} \left[(\pi + \alpha - \alpha) - \left(\frac{\sin 2(\pi + \alpha) - \sin 2\alpha}{2} \right) \right]}$$

$$V_{O(RMS)} = \sqrt{\frac{V_m^2}{2\pi} \left[(\pi) - \left(\frac{\sin (2\pi + 2\alpha) - \sin 2\alpha}{2} \right) \right]};$$

$$\sin (2\pi + 2\alpha) = \sin 2\alpha$$

$$V_{O(RMS)} = \sqrt{\frac{V_m^2}{2\pi} \left[(\pi) - \left(\frac{\sin 2\alpha - \sin 2\alpha}{2} \right) \right]}$$

$$V_{O(RMS)} = \sqrt{\frac{V_m^2}{2\pi} (\pi) - 0} = \sqrt{\frac{V_m^2}{2}} = \frac{V_m}{\sqrt{2}}$$

$$\therefore V_{O(RMS)} = \frac{V_m}{\sqrt{2}} = V_s$$

Hence the rms output voltage is same as the rms input supply voltage

4.7.3 Thyristor Current Waveforms

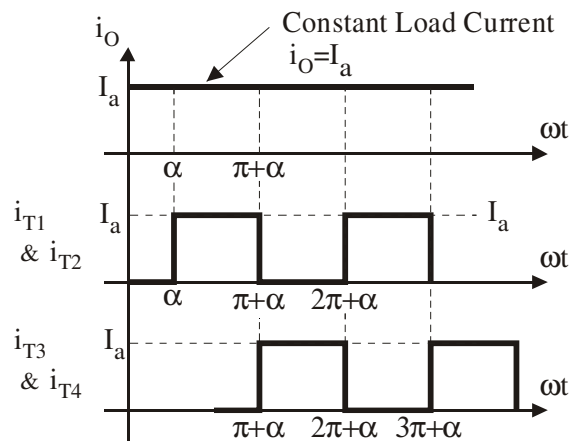

The rms thyristor current can be calculated as

$$I_{T(RMS)} = \frac{I_{O(RMS)}}{\sqrt{2}}$$

The average thyristor current can be calculated as

$$I_{T(Avg)} = \frac{I_{O(dc)}}{2}$$

4.8 Single Phase Dual Converter

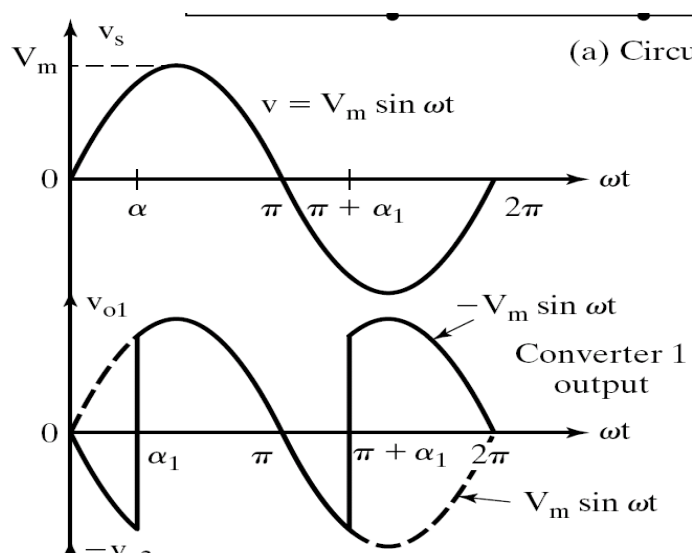
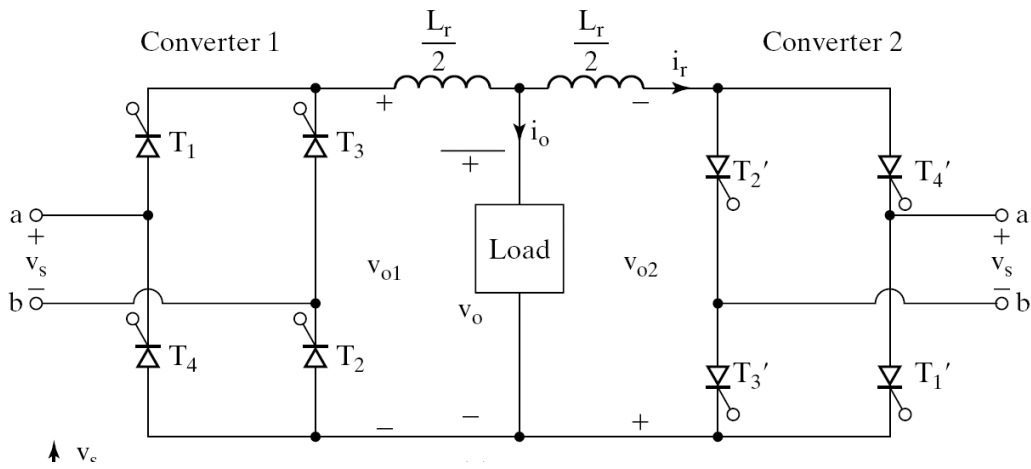

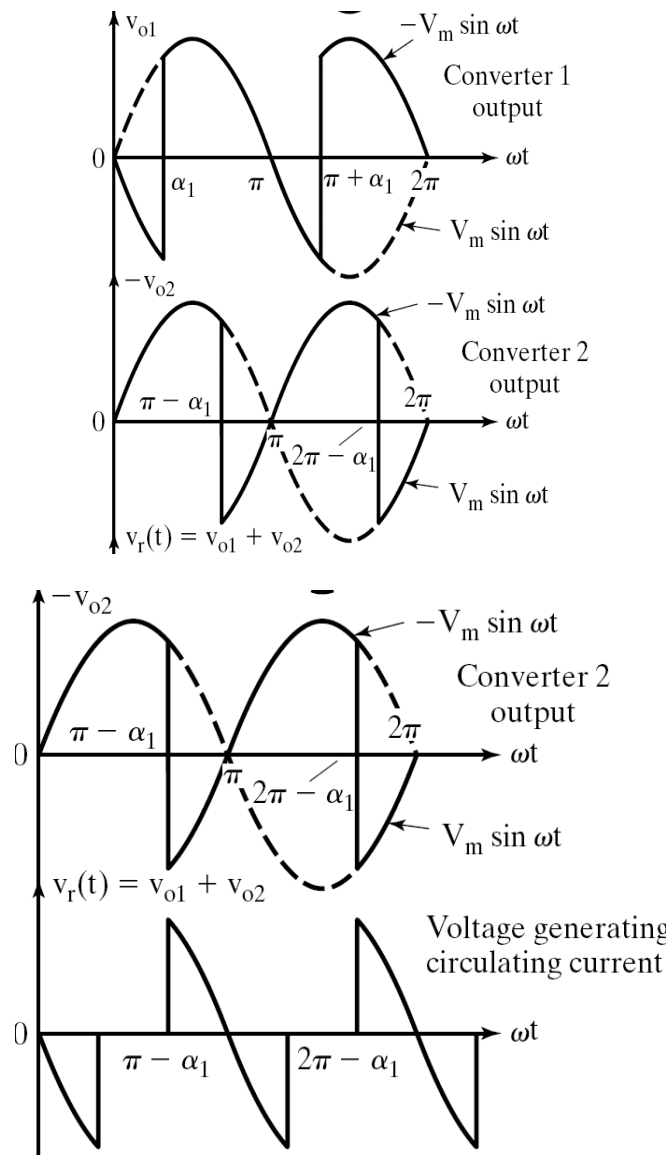

The average dc output voltage of converter 1 is

$$V_{dc1} = \frac{2V_m}{\pi} \cos \alpha_1$$

The average dc output voltage of converter 2 is

$$V_{dc2} = \frac{2V_m}{\pi} \cos \alpha_2$$

In the dual converter operation one converter is operated as a controlled rectifier with $\alpha < 90^\circ$ & the second converter is operated as a line commutated inverter in the inversion mode with $\alpha > 90^\circ$

$$\therefore V_{dc1} = -V_{dc2}$$

$$\frac{2V_m}{\pi} \cos \alpha_1 = \frac{-2V_m}{\pi} \cos \alpha_2 = \frac{2V_m}{\pi} (-\cos \alpha_2)$$

$$\therefore \cos \alpha_1 = -\cos \alpha_2$$

or

$$\cos \alpha_2 = -\cos \alpha_1 = \cos(\pi - \alpha_1)$$

$$\therefore \alpha_2 = (\pi - \alpha_1) \text{ or}$$

$$(\alpha_1 + \alpha_2) = \pi \text{ radians}$$

Which gives

$$\alpha_2 = (\pi - \alpha_1)$$

(i) To Obtain an Expression for the Instantaneous Circulating Current

- v_{O1} = Instantaneous o/p voltage of converter 1.
- v_{O2} = Instantaneous o/p voltage of converter 2.
- The circulating current i_r can be determined by integrating the instantaneous voltage difference (which is the voltage drop across the circulating current reactor L_r), starting from $\omega t = (2\pi - \alpha_1)$.
- As the two average output voltages during the interval $\omega t = (\pi + \alpha_1)$ to $(2\pi - \alpha_1)$ are equal and opposite their contribution to the instantaneous circulating current i_r is zero.

$$i_r = \frac{1}{\omega L_r} \left[\int_{(2\pi - \alpha_1)}^{\omega t} v_r \cdot d(\omega t) \right]; \quad v_r = (v_{O1} - v_{O2})$$

As the o/p voltage v_{O2} is negative

$$v_r = (v_{O1} + v_{O2})$$

$$\therefore i_r = \frac{1}{\omega L_r} \left[\int_{(2\pi - \alpha_1)}^{\omega t} (v_{O1} + v_{O2}) \cdot d(\omega t) \right];$$

$$v_{O1} = -V_m \sin \omega t \text{ for } (2\pi - \alpha_1) \text{ to } \omega t$$

$$i_r = \frac{V_m}{\omega L_r} \left[\int_{(2\pi - \alpha_1)}^{\omega t} -\sin \omega t \cdot d(\omega t) - \int_{(2\pi - \alpha_1)}^{\omega t} \sin \omega t \cdot d(\omega t) \right]$$

$$i_r = \frac{2V_m}{\omega L_r} (\cos \omega t - \cos \alpha_1)$$

The instantaneous value of the circulating current depends on the delay angle.

For trigger angle (delay angle) $\alpha_1 = 0$,

the magnitude of circulating current becomes min.

when $\omega t = n\pi$, $n = 0, 2, 4, \dots$ & magnitude becomes

If the peak load current is I_p , one of the

converters that controls the power flow

may carry a peak current of

where

$$I_p = I_{L(\max)} = \frac{V_m}{R_L},$$

&

$$i_{r(\max)} = \frac{4V_m}{\omega L_r} = \text{max. circulating current}$$

The Dual Converter Can Be Operated In Two Different Modes Of Operation

- Non-circulating current (circulating current free) mode of operation.
- Circulating current mode of operation

Non-Circulating Current Mode of Operation

- In this mode only one converter is operated at a time.
- When converter 1 is ON, $0 < \alpha_1 < 90^\circ$
- V_{dc} is positive and I_{dc} is positive.
- When converter 2 is ON, $0 < \alpha_2 < 90^\circ$
- V_{dc} is negative and I_{dc} is negative.

Circulating Current Mode Of Operation

- In this mode, both the converters are switched ON and operated at the same time.
- The trigger angles α_1 and α_2 are adjusted such that $(\alpha_1 + \alpha_2) = 180^\circ$; $\alpha_2 = (180^\circ - \alpha_1)$.
- When $0 < \alpha_1 < 90^\circ$, converter 1 operates as a controlled rectifier and converter 2 operates as an inverter with $90^\circ < \alpha_2 < 180^\circ$.
- In this case V_{dc} and I_{dc} , both are positive.
- When $90^\circ < \alpha_1 < 180^\circ$, converter 1 operates as an Inverter and converter 2 operated as a controlled rectifier by adjusting its trigger angle α_2 such that $0 < \alpha_2 < 90^\circ$.
- In this case V_{dc} and I_{dc} , both are negative.

4.8.1 Four Quadrant Operation

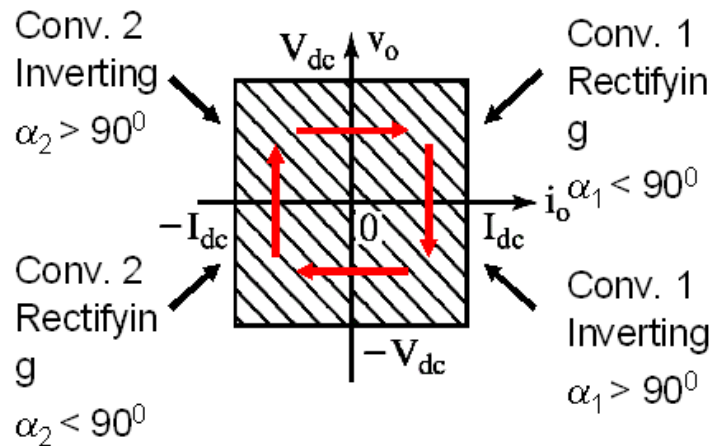

Advantages of Circulating Current Mode of Operation

- The circulating current maintains continuous conduction of both the converters over the complete control range, independent of the load.
- One converter always operates as a rectifier and the other converter operates as an inverter, the power flow in either direction at any time is possible.
- As both the converters are in continuous conduction we obtain faster dynamic response. i.e., the time response for changing from one quadrant operation to another is faster.

Disadvantages of Circulating Current Mode of Operation

- There is always a circulating current flowing between the converters.
- When the load current falls to zero, there will be a circulating current flowing between the converters so we need to connect circulating current reactors in order to limit the peak circulating current to safe level.
- The converter thyristors should be rated to carry a peak current much greater than the peak load current.

Recommended questions:

1. Give the classification of converters, based on: a) Quadrant operation b) Number of current pulse c) supply input. Give examples in each case.
2. With neat circuit diagram and wave forms, explain the working of 1 phase HWR using SCR for R-load. Derive the expressions for V_{dc} and I_{dc} .
3. With a neat circuit diagram and waveforms, explain the working of 1-phase HCB for R-load and R-L-load.
4. Determine the performance factors for 1-phase HCB circuit.

5. With a neat circuit diagram and waveforms, explain the working of 1-phase FCB for R and R-L-loads.
6. Determine the performance factors for 1-phase FCB circuit.
7. What is dual converter? Explain the working principle of 1-phase dual converter. What are the modes of operation of dual converters? Explain briefly.
8. With a neat circuit diagram and waveforms explain the working of 3 phase HHCB using SCRs. Obtain the expressions for V_{dc} and I_{dc} .
9. With a neat circuit diagram and waveforms, explain the working of 3-phase HWR using SCRs. Obtain the expressions for V_{dc} and I_{dc} .
10. With a neat circuit diagram and waveforms, explain the working of 3 phase FCB using SCRs. Obtain the expressions for V_{dc} and I_{dc} .
11. Draw the circuit diagram of 3 phase dual converter. Explain its working?
12. List the applications of converters. Explain the effect of battery in the R-L-E load in converters.
13. A single phase half wave converter is operated from a 120V, 60 Hz supply. If the load resistive load is $R=10\Omega$ and the delay angle is $\alpha=\pi/3$, determine a) the efficiency b) the form factor c) the transformer utilization factor and d) the peak inverse voltage (PIV) of thyristor T1
14. A single phase half wave converter is operated from a 120 V, 60 Hz supply and the load resistive load is $R=10\Omega$. If the average output voltage is 25% of the maximum possible average output voltage, calculate a) the delay angle b) the rms and average output current c) the average and rms thyristor current and d) the input power factor.
15. A single half wave converter is operated from a 120 V, 60Hz supply and freewheeling diodes is connected across the load. The load consists of series-connected resistance $R=10\Omega$, $L=5mH$, and battery voltage $E=20V$. a) Express the instantaneous output voltage in a Fourier series, and b) determine the rms value of the lowest order output harmonic current.
16. A single phase semi-converter is operated from 120V, 60 Hz supply. The load current with an average value of I_a is continuous with negligible ripple content. The turns ratio of the transformer is unity. If the delay angle is $\alpha= \pi/3$, calculate a) the harmonic factor of input current b) the displacement factor and c) the input power factor.
17. A single phase semi converter is operated from 120V, 60Hz supply. The load consists of series connected resistance $R=10\Omega$, $L=5mH$ and battery voltage $E=20V$. a) Express the instantaneous output voltage in a Fourier series, b) Determine the rms value of the lowest order output harmonic current.
18. The three phase half wave converter is operated from a three phase Y connected 220V, 60Hz supply and freewheeling diodes is connected across the load. The load consists of series connected resistance $R=10\Omega$, $L=5mH$ and battery voltage $E=120V$. a) Express the instantaneous output voltage in a Fourier series and b) Determine the rms value of the lowest order output harmonic current.

13. without a series inductor? What is the ratio of peak resonant to load current for resonant pulse commutation that would minimize the commutation losses?
14. Why does the commutation capacitor in a resonant pulse commutation get over charged?
15. How is the voltage of the commutation capacitor reversed in a commutation circuit?
16. What is the type of a capacitor used in high frequency switching circuits?

UNIT-6

DC Choppers

7.1 Introduction

- Chopper is a static device.
- A variable dc voltage is obtained from a constant dc voltage source.
- Also known as dc-to-dc converter.
- Widely used for motor control.
- Also used in regenerative braking.
- Thyristor converter offers greater efficiency, faster response, lower maintenance, smaller size and smooth control.

Choppers are of Two Types

- Step-down choppers.
- Step-up choppers.
 - In step down chopper output voltage is less than input voltage.
 - In step up chopper output voltage is more than input voltage.

7.2 Principle of Step-down Chopper

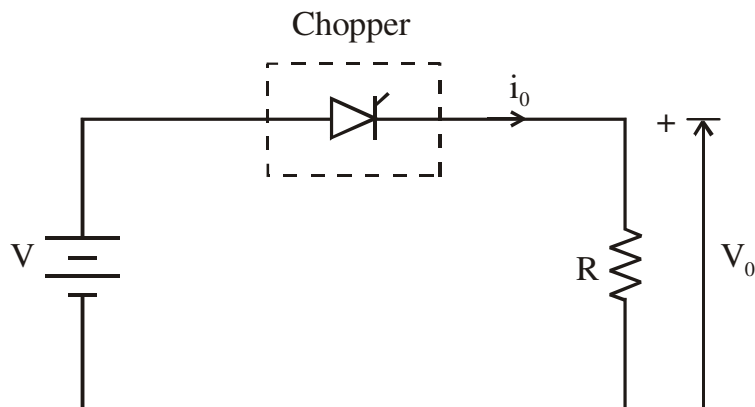

- A step-down chopper with resistive load.
- The thyristor in the circuit acts as a switch.
- When thyristor is ON, supply voltage appears across the load
- When thyristor is OFF, the voltage across the load will be zero.

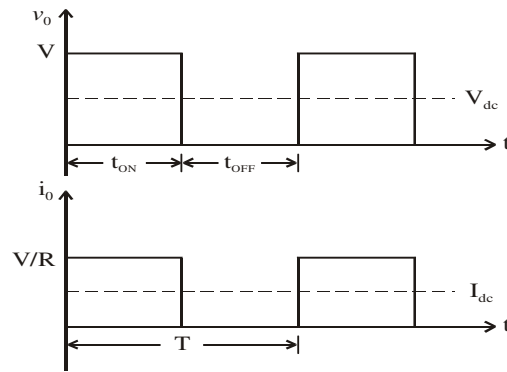

V_{dc} = Average value of output or load voltage.

I_{dc} = Average value of output or load current.

t_{ON} = Time interval for which SCR conducts.

t_{OFF} = Time interval for which SCR is OFF.

$T = t_{ON} + t_{OFF}$ = Period of switching or chopping period.

$f = \frac{1}{T}$ = Freq. of chopper switching or chopping freq.

Average Output Voltage

$$V_{dc} = V \left(\frac{t_{ON}}{t_{ON} + t_{OFF}} \right)$$

$$V_{dc} = V \left(\frac{t_{ON}}{T} \right) = V.d$$

$$\text{but } \left(\frac{t_{ON}}{T} \right) = d = \text{duty cycle}$$

Average Output Current

$$I_{dc} = \frac{V_{dc}}{R}$$

$$I_{dc} = \frac{V}{R} \left(\frac{t_{ON}}{T} \right) = \frac{V}{R} d$$

RMS value of output voltage

$$V_o = \sqrt{\frac{1}{T} \int_0^{t_{ON}} v_o^2 dt}$$

But during t_{ON} , $v_o = V$

Therefore RMS output voltage

$$V_o = \sqrt{\frac{1}{T} \int_0^{t_{ON}} V^2 dt}$$

$$V_o = \sqrt{\frac{V^2}{T} t_{ON}} = \sqrt{\frac{t_{ON}}{T}} \cdot V$$

$$V_o = \sqrt{d} \cdot V$$

Output power $P_o = V_o I_o$

But $I_o = \frac{V_o}{R}$

∴ Output power

$$P_o = \frac{V_o^2}{R}$$

$$P_o = \frac{dV^2}{R}$$

Effective input resistance of chopper

$$R_i = \frac{V}{I_{dc}}$$

$$R_i = \frac{R}{d}$$

The output voltage can be varied by varying the duty cycle.

Methods of Control

- The output dc voltage can be varied by the following methods.
 - Pulse width modulation control or constant frequency operation.
 - Variable frequency control.
 -

Pulse Width Modulation

- t_{ON} is varied keeping chopping frequency ' f ' & chopping period ' T ' constant.
- Output voltage is varied by varying the ON time t_{ON}

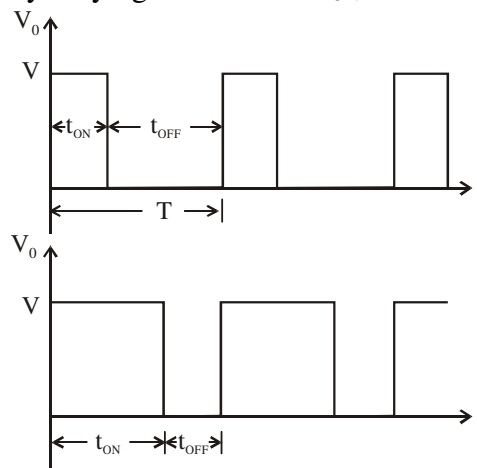

Variable Frequency Control

- Chopping frequency ' f ' is varied keeping either t_{ON} or t_{OFF} constant.
- To obtain full output voltage range, frequency has to be varied over a wide range.
- This method produces harmonics in the output and for large t_{OFF} load current may become discontinuous

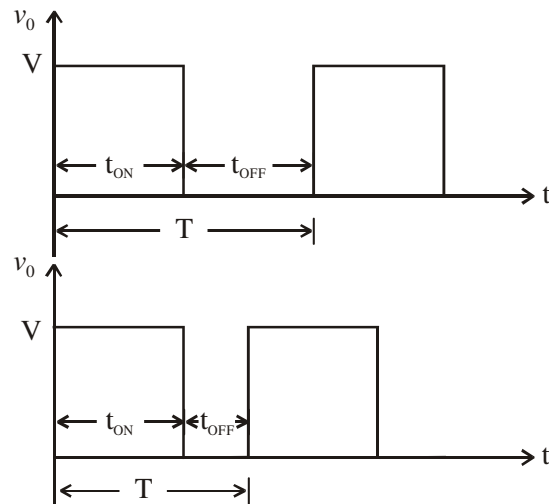

7.2.1 Step-down Chopper with R-L Load

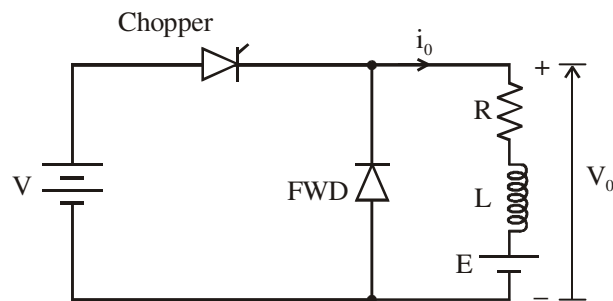

- When chopper is ON, supply is connected across load.
- Current flows from supply to load.
- When chopper is OFF, load current continues to flow in the same direction through FWD due to energy stored in inductor 'L'.
- Load current can be continuous or discontinuous depending on the values of 'L' and duty cycle 'd'
- For a continuous current operation, load current varies between two limits I_{max} and I_{min}
- When current becomes equal to I_{max} the chopper is turned-off and it is turned-on when current reduces to I_{min} .

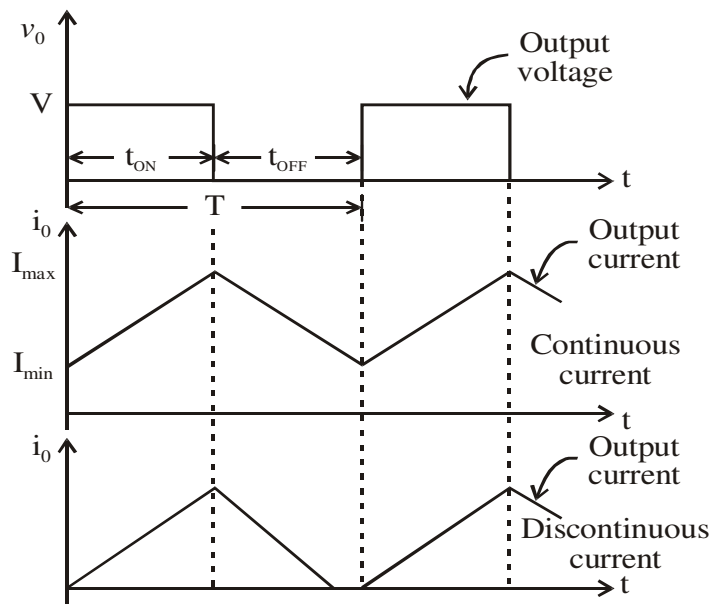

Expressions for Load Current I_o for Continuous Current Operation When Chopper is ON ($0 \leq T \leq T_{on}$)

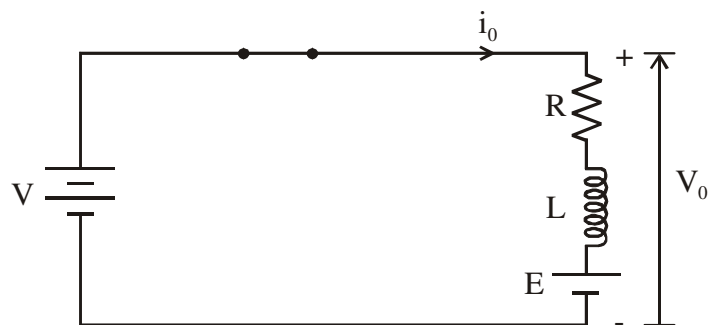

$$V = i_o R + L \frac{di_o}{dt} + E$$

Taking Laplace Transform

$$\frac{V}{S} = R I_o(S) + L [S I_o(S) - i_o(0^-)] + \frac{E}{S}$$

At $t = 0$, initial current $i_o(0^-) = I_{min}$

$$I_o(S) = \frac{V - E}{LS \left(S + \frac{R}{L} \right)} + \frac{I_{min}}{S + \frac{R}{L}}$$

Taking Inverse Laplace Transform

$$i_o(t) = \frac{V-E}{R} \left[1 - e^{-\left(\frac{R}{L}\right)t} \right] + I_{\min} e^{-\left(\frac{R}{L}\right)t}$$

This expression is valid for $0 \leq t \leq t_{ON}$,
i.e., during the period chopper is ON.

At the instant the chopper is turned off,
load current is $i_o(t_{ON}) = I_{\max}$

When Chopper is OFF

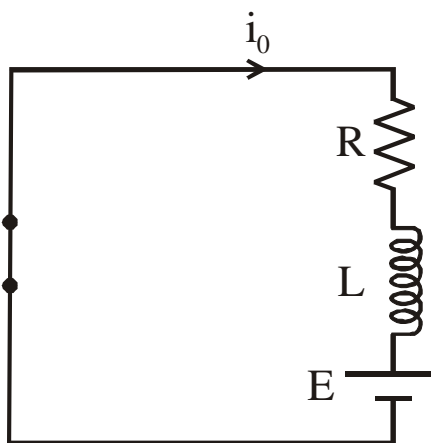

When Chopper is OFF ($0 \leq t \leq t_{OFF}$)

$$0 = Ri_o + L \frac{di_o}{dt} + E$$

Taking Laplace transform

$$0 = RI_o(S) + L \left[SI_o(S) - i_o(0^-) \right] + \frac{E}{S}$$

Redefining time origin we have at $t = 0$,

$$\text{initial current } i_o(0^-) = I_{\max}$$

$$\therefore I_o(S) = \frac{I_{\max}}{S + \frac{R}{L}} - \frac{E}{LS \left(S + \frac{R}{L} \right)}$$

Taking Inverse Laplace Transform

$$i_o(t) = I_{\max} e^{-\frac{R}{L}t} - \frac{E}{R} \left[1 - e^{-\frac{R}{L}t} \right]$$

The expression is valid for $0 \leq t \leq t_{OFF}$,
i.e., during the period chopper is OFF

At the instant the chopper is turned ON or at
the end of the off period, the load current is

$$i_o(t_{OFF}) = I_{\min}$$

To Find I_{\max} & I_{\min}

From equation

$$i_o(t) = \frac{V-E}{R} \left[1 - e^{-\left(\frac{R}{L}\right)t} \right] + I_{\min} e^{-\left(\frac{R}{L}\right)t}$$

At $t = t_{ON} = dT$, $i_o(t) = I_{\max}$

$$\therefore I_{\max} = \frac{V-E}{R} \left[1 - e^{-\frac{dRT}{L}} \right] + I_{\min} e^{-\frac{dRT}{L}}$$

From equation

$$i_o(t) = I_{\max} e^{-\frac{Rt}{L}} - \frac{E}{R} \left[1 - e^{-\frac{Rt}{L}} \right]$$

At $t = t_{OFF} = T - t_{ON}$, $i_o(t) = I_{\min}$

$$t = t_{OFF} = (1-d)T$$

$$\therefore I_{\min} = I_{\max} e^{-\frac{(1-d)RT}{L}} - \frac{E}{R} \left[1 - e^{-\frac{(1-d)RT}{L}} \right]$$

Substituting for I_{\min} in equation

$$I_{\max} = \frac{V-E}{R} \left[1 - e^{-\frac{dRT}{L}} \right] + I_{\min} e^{-\frac{dRT}{L}}$$

we get,

$$I_{\max} = \frac{V}{R} \left[\frac{1 - e^{-\frac{dRT}{L}}}{1 - e^{-\frac{RT}{L}}} \right] - \frac{E}{R}$$

Substituting for I_{\max} in equation

$$I_{\min} = I_{\max} e^{-\frac{(1-d)RT}{L}} - \frac{E}{R} \left[1 - e^{-\frac{(1-d)RT}{L}} \right]$$

we get,

$$I_{\min} = \frac{V}{R} \left[\frac{e^{-\frac{dRT}{L}} - 1}{e^{-\frac{RT}{L}} - 1} \right] - \frac{E}{R}$$

Dept. of ECE / SJBIT
($I_{\max} - I_{\min}$) is known as the steady state ripple.

Therefore peak-to-peak ripple current

$$\Delta I = I_{\max} - I_{\min}$$

Average output voltage

$$V_{dc} = d.V$$

Average output current

$$I_{dc(\text{approx})} = \frac{I_{\max} + I_{\min}}{2}$$

Assuming load current varies linearly

from I_{\min} to I_{\max} instantaneous

load current is given by

$$i_o = I_{\min} + \frac{(\Delta I).t}{dT} \text{ for } 0 \leq t \leq t_{ON} (dT)$$

$$i_o = I_{\min} + \left(\frac{I_{\max} - I_{\min}}{dT} \right) t$$

RMS value of load current

$$I_{O(RMS)} = \sqrt{\frac{1}{dT} \int_0^{dT} i_o^2 dt}$$

$$I_{O(RMS)} = \sqrt{\frac{1}{dT} \int_0^{dT} \left[I_{\min} + \frac{(I_{\max} - I_{\min})t}{dT} \right]^2 dt}$$

$$I_{O(RMS)} = \sqrt{\frac{1}{dT} \int_0^{dT} \left[I_{\min}^2 + \left(\frac{I_{\max} - I_{\min}}{dT} \right)^2 t^2 + \frac{2I_{\min} (I_{\max} - I_{\min})t}{dT} \right] dt}$$

$$I_{CH} = \sqrt{d} \left[I_{\min}^2 + \frac{(I_{\max} - I_{\min})^2}{3} + I_{\min} (I_{\max} - I_{\min}) \right]^{\frac{1}{2}}$$

$$I_{CH} = \sqrt{d} I_{O(RMS)}$$

Effective input resistance is

$$R_i = \frac{V}{I_s}$$

Where

$I_s =$ Average source current

$$I_s = dI_{dc}$$

$$\therefore R_i = \frac{V}{dI_{dc}}$$

7.3 Principle of Step-up Chopper

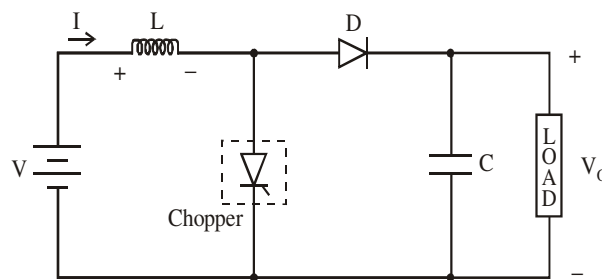

- Step-up chopper is used to obtain a load voltage higher than the input voltage V .
- The values of L and C are chosen depending upon the requirement of output voltage and current.
- When the chopper is *ON*, the inductor L is connected across the supply.
- The inductor current ' I ' rises and the inductor stores energy during the *ON* time of the chopper, t_{ON} .
- When the chopper is off, the inductor current I is forced to flow through the diode D and load for a period, t_{OFF} .
- The current tends to decrease resulting in reversing the polarity of induced EMF in L .
- Therefore voltage across load is given by

$$V_o = V + L \frac{dI}{dt} \quad \text{i.e., } V_o > V$$

- A large capacitor ' C ' connected across the load, will provide a continuous output voltage .
- Diode D prevents any current flow from capacitor to the source.
- Step up choppers are used for regenerative braking of dc motors.

(i) Expression For Output Voltage

Assume the average inductor current to be I during ON and OFF time of Chopper.

When Chopper is ON

Voltage across inductor $L = V$

Therefore energy stored in inductor

$$= V \cdot I \cdot t_{ON}$$

Where $t_{ON} = ON$ period of chopper.

When Chopper is OFF

(energy is supplied by inductor to load)

Voltage across $L = V_o - V$

Energy supplied by inductor $L = (V_o - V) I t_{OFF}$

where $t_{OFF} = OFF$ period of Chopper.

Neglecting losses, energy stored in inductor

$L =$ energy supplied by inductor L

$$\therefore V I t_{ON} = (V_o - V) I t_{OFF}$$

$$V_o = \frac{V [t_{ON} + t_{OFF}]}{t_{OFF}}$$

$$V_o = V \left(\frac{T}{T - t_{ON}} \right)$$

Where

$T =$ Chopping period or period of switching.

$$T = t_{ON} + t_{OFF}$$

$$V_o = V \left(\frac{1}{1 - \frac{t_{ON}}{T}} \right)$$

$$\therefore V_o = V \left(\frac{1}{1 - d} \right)$$

Where $d = \frac{t_{ON}}{T} =$ duty cycle

Performance Parameters

- The thyristor requires a certain minimum time to turn *ON* and turn *OFF*.
- Duty cycle d can be varied only between a min. & max. value, limiting the min. and max. value of the output voltage.
- Ripple in the load current depends inversely on the chopping frequency, f .
- To reduce the load ripple current, frequency should be as high as possible.

Problem

1. A Chopper circuit is operating on TRC at a frequency of 2 kHz on a 460 V supply. If the load voltage is 350 volts, calculate the conduction period of the thyristor in each cycle.

Solution:

$$V = 460 \text{ V}, V_{dc} = 350 \text{ V}, f = 2 \text{ kHz}$$

$$\text{Chopping period} \quad T = \frac{1}{f}$$

$$T = \frac{1}{2 \times 10^{-3}} = 0.5 \text{ msec}$$

$$\text{Output voltage} \quad V_{dc} = \left(\frac{t_{ON}}{T} \right) V$$

Conduction period of thyristor

$$t_{ON} = \frac{T \times V_{dc}}{V}$$

$$t_{ON} = \frac{0.5 \times 10^{-3} \times 350}{460}$$

$$t_{ON} = 0.38 \text{ msec}$$

Problem

2. Input to the step up chopper is 200 V. The output required is 600 V. If the conducting time of thyristor is 200 μ sec. Compute

- Chopping frequency,
- If the pulse width is halved for constant frequency of operation, find the new output voltage.

Solution:

$$V = 200 \text{ V}, t_{ON} = 200 \mu\text{s}, V_{dc} = 600 \text{ V}$$

$$V_{dc} = V \left(\frac{T}{T - t_{ON}} \right)$$

$$600 = 200 \left(\frac{T}{T - 200 \times 10^{-6}} \right)$$

Solving for T

$$T = 300 \mu\text{s}$$

Chopping frequency

$$f = \frac{1}{T}$$

$$f = \frac{1}{300 \times 10^{-6}} = 3.33 \text{ KHz}$$

Pulse width is halved

$$\therefore t_{ON} = \frac{200 \times 10^{-6}}{2} = 100 \mu s$$

Frequency is constant

$$\therefore f = 3.33 \text{ KHz}$$

$$T = \frac{1}{f} = 300 \mu s$$

$$\begin{aligned} \therefore \text{Output voltage} &= V \left(\frac{T}{T - t_{ON}} \right) \\ &= 200 \left(\frac{300 \times 10^{-6}}{(300 - 100) \times 10^{-6}} \right) = 300 \text{ Volts} \end{aligned}$$

Problem

3. A dc chopper has a resistive load of 20Ω and input voltage $V_S = 220V$. When chopper is ON, its voltage drop is 1.5 volts and chopping frequency is 10 kHz. If the duty cycle is 80%, determine the average output voltage and the chopper on time.

Solution:

$$V_S = 220V, R = 20\Omega, f = 10 \text{ kHz}$$

$$d = \frac{t_{ON}}{T} = 0.80$$

$$V_{ch} = \text{Voltage drop across chopper} = 1.5 \text{ volts}$$

Average output voltage

$$V_{dc} = \left(\frac{t_{ON}}{T} \right) (V_S - V_{ch})$$

$$V_{dc} = 0.80(220 - 1.5) = 174.8 \text{ Volts}$$

$$\text{Chopper ON time, } t_{ON} = dT$$

$$\text{Chopping period, } T = \frac{1}{f}$$

$$T = \frac{1}{10 \times 10^3} = 0.1 \times 10^{-3} \text{ secs} = 100 \mu\text{secs}$$

$$\text{Chopper ON time,}$$

$$t_{ON} = dT$$

$$t_{ON} = 0.80 \times 0.1 \times 10^{-3}$$

$$t_{ON} = 0.08 \times 10^{-3} = 80 \mu\text{secs}$$

Problem

4. In a dc chopper, the average load current is 30 Amps, chopping frequency is 250 Hz, supply voltage is 110 volts. Calculate the ON and OFF periods of the chopper if the load resistance is 2 ohms.

Solution:

$$I_{dc} = 30 \text{ Amps, } f = 250 \text{ Hz, } V = 110 \text{ V, } R = 2\Omega$$

$$\text{Chopping period, } T = \frac{1}{f} = \frac{1}{250} = 4 \times 10^{-3} = 4 \text{ msec}$$

$$I_{dc} = \frac{V_{dc}}{R} \text{ \& } V_{dc} = dV$$

$$\therefore I_{dc} = \frac{dV}{R}$$

$$d = \frac{I_{dc} R}{V} = \frac{30 \times 2}{110} = 0.545$$

$$\text{Chopper ON period,}$$

$$t_{ON} = dT = 0.545 \times 4 \times 10^{-3} = 2.18 \text{ msec}$$

$$\text{Chopper OFF period,}$$

$$t_{OFF} = T - t_{ON}$$

$$t_{OFF} = 4 \times 10^{-3} - 2.18 \times 10^{-3}$$

$$t_{OFF} = 1.82 \times 10^{-3} = 1.82 \text{ msec}$$

Problem

5. A dc chopper in figure has a resistive load of $R = 10\Omega$ and input voltage of $V = 200$ V. When chopper is ON, its voltage drop is 2 V and the chopping frequency is 1 kHz. If the duty cycle is 60%, determine

- Average output voltage

- RMS value of output voltage
- Effective input resistance of chopper
- Chopper efficiency.

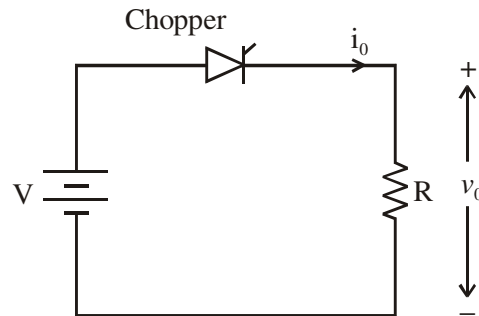
**Solution:**

$$V = 200 \text{ V}, R = 10\Omega, \text{ Chopper voltage drop } V_{ch} = 2\text{V}$$

$$d = 0.60, f = 1 \text{ kHz.}$$

Average output voltage

$$V_{dc} = d(V - V_{ch})$$

$$V_{dc} = 0.60[200 - 2] = 118.8 \text{ Volts}$$

RMS value of output voltage

$$V_o = \sqrt{d}(V - V_{ch})$$

$$V_o = \sqrt{0.6}(200 - 2) = 153.37 \text{ Volts}$$

Effective input resistance of chopper is

$$R_i = \frac{V}{I_s} = \frac{V}{I_{dc}}$$

$$I_{dc} = \frac{V_{dc}}{R} = \frac{118.8}{10} = 11.88 \text{ Amps}$$

$$R_i = \frac{V}{I_s} = \frac{V}{I_{dc}} = \frac{200}{11.88} = 16.83\Omega$$

Output power is

$$P_o = \frac{1}{T} \int_0^T \frac{v_o^2}{R} dt = \frac{1}{T} \int_0^T \frac{(V - V_{ch})^2}{R} dt$$

$$P_o = \frac{d(V - V_{ch})^2}{R}$$

$$P_o = \frac{0.6[200 - 2]^2}{10} = 2352.24 \text{ watts}$$

Input power,

$$P_i = \frac{1}{T} \int_0^T V i_o dt$$

$$P_i = \frac{1}{T} \int_0^T \frac{V(V - V_{ch})}{R} dt$$

7.4 Classification of Choppers

Choppers are classified as

- Class A Chopper
- Class B Chopper
- Class C Chopper
- Class D Chopper
- Class E Chopper

1. Class A Chopper

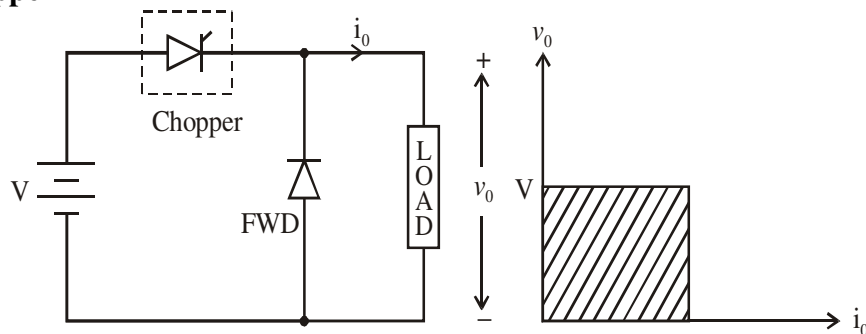

- When chopper is *ON*, supply voltage V is connected across the load.
- When chopper is *OFF*, $v_0 = 0$ and the load current continues to flow in the same direction through the FWD.
- The average values of output voltage and current are always positive.
- *Class A Chopper* is a first quadrant chopper .
- *Class A Chopper* is a step-down chopper in which power always flows form source to load.
- It is used to control the speed of dc motor.
- The output current equations obtained in step down chopper with $R-L$ load can be used to study the performance of *Class A Chopper*.

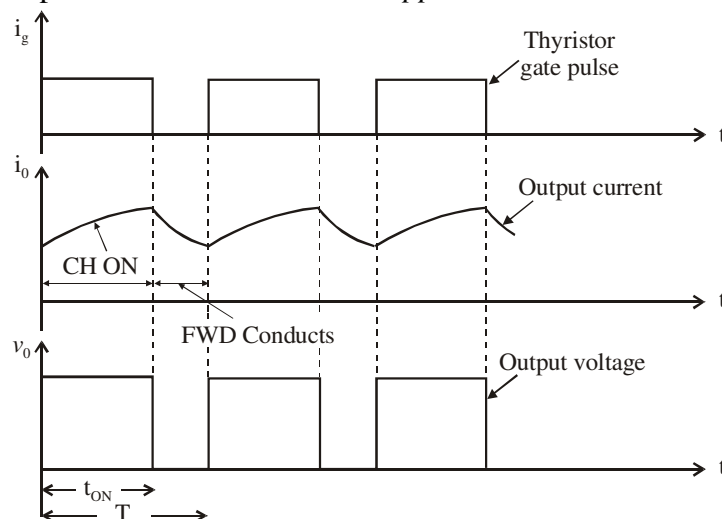

2. Class B Chopper

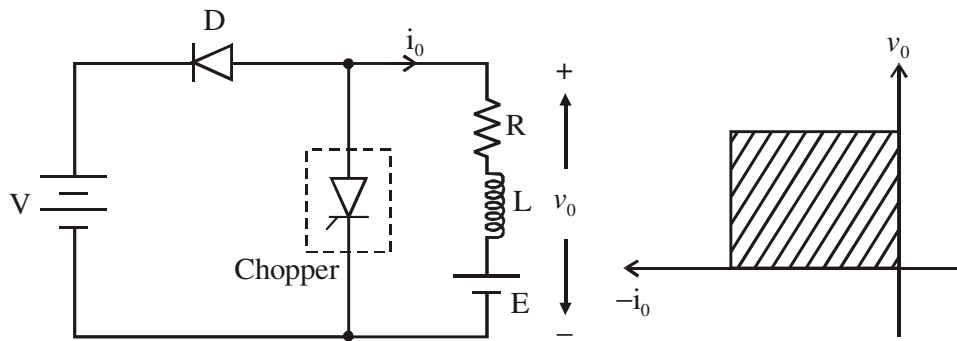

- When chopper is ON, E drives a current through L and R in a direction opposite to that shown in figure.
- During the ON period of the chopper, the inductance L stores energy.
- When Chopper is OFF, diode D conducts, and part of the energy stored in inductor L is returned to the supply.
- Average output voltage is positive.
- Average output current is negative.
- Therefore *Class B Chopper* operates in second quadrant.
- In this chopper, power flows from load to source.
- *Class B Chopper* is used for regenerative braking of dc motor.
- *Class B Chopper* is a step-up chopper.

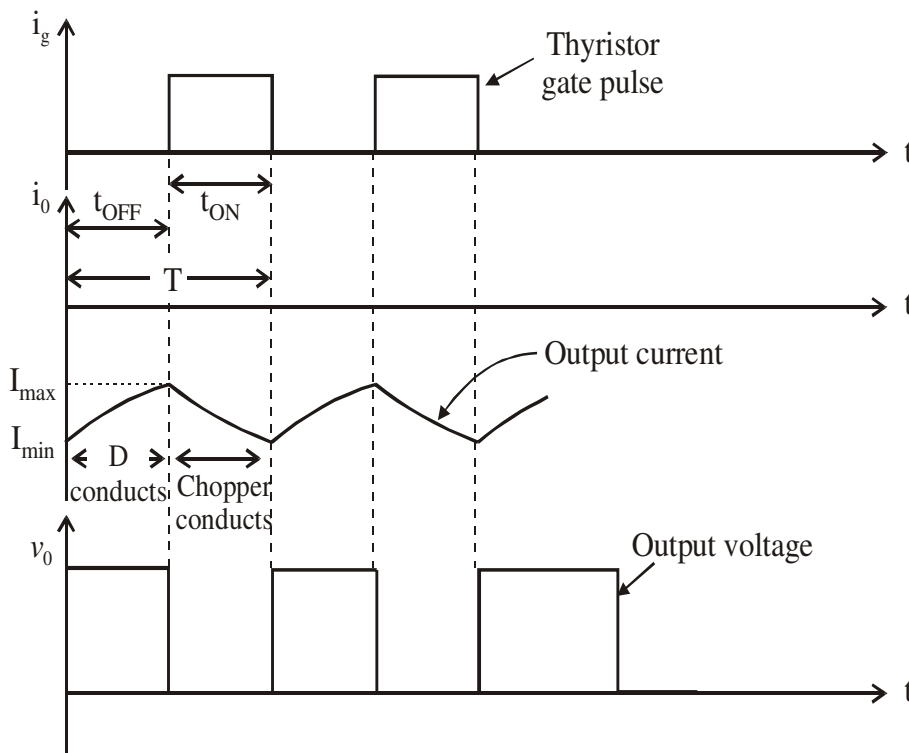

(i) Expression for Output Current

During the interval diode 'D' conducts
voltage equation is given by

$$V = \frac{L di_o}{dt} + Ri_o + E$$

For the initial condition i.e.,

$$i_o(t) = I_{\min} \text{ at } t = 0$$

The solution of the above equation is obtained along similar lines as in step-down chopper with R-L load

$$\therefore i_o(t) = \frac{V-E}{R} \left(1 - e^{-\frac{R}{L}t} \right) + I_{\min} e^{-\frac{R}{L}t} \quad 0 < t < t_{OFF}$$

$$\text{At } t = t_{OFF} \quad i_{(o)}(t) = I_{\max}$$

$$I_{\max} = \frac{V-E}{R} \left(1 - e^{-\frac{R}{L}t_{OFF}} \right) + I_{\min} e^{-\frac{R}{L}t_{OFF}}$$

During the interval chopper is ON voltage equation is given by

$$0 = \frac{L di_o}{dt} + Ri_o + E$$

Redefining the time origin, at $t = 0 \quad i_o(t) = I_{\max}$

The solution for the stated initial condition is

$$i_o(t) = I_{\max} e^{-\frac{R}{L}t} - \frac{E}{R} \left(1 - e^{-\frac{R}{L}t} \right) \quad 0 < t < t_{ON}$$

$$\text{At } t = t_{ON} \quad i_o(t) = I_{\min}$$

$$\therefore I_{\min} = I_{\max} e^{-\frac{R}{L}t_{ON}} - \frac{E}{R} \left(1 - e^{-\frac{R}{L}t_{ON}} \right)$$

3. Class C Chopper

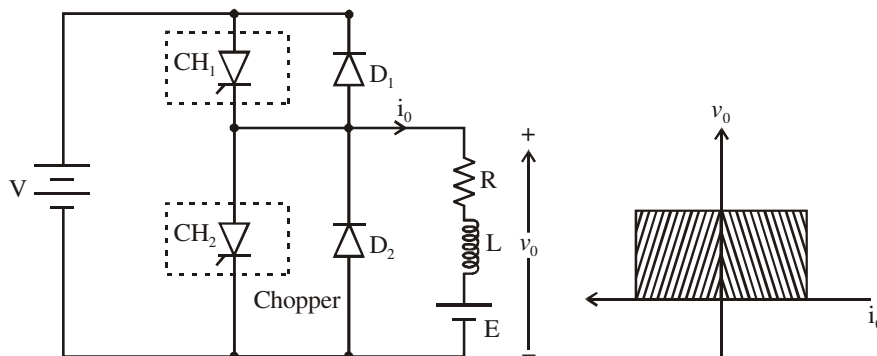

- *Class C Chopper* is a combination of *Class A* and *Class B Choppers*.
- For first quadrant operation, CH_1 is ON or D_2 conducts.
- For second quadrant operation, CH_2 is ON or D_1 conducts.
- When CH_1 is ON, the load current is positive.
- The output voltage is equal to ' V ' & the load receives power from the source.
- When CH_1 is turned OFF, energy stored in inductance L forces current to flow through the diode D_2 and the output voltage is zero.
- Current continues to flow in positive direction.
- When CH_2 is triggered, the voltage E forces current to flow in opposite direction through L and CH_2 .
- The output voltage is zero.
- On turning OFF CH_2 , the energy stored in the inductance drives current through diode D_1 and the supply.
- Output voltage is V , the input current becomes negative and power flows from load to source.
- Average output voltage is positive.
- Average output current can take both positive and negative values.
- Choppers CH_1 & CH_2 should not be turned ON simultaneously as it would result in short circuiting the supply.
- *Class C Chopper* can be used both for dc motor control and regenerative braking of dc motor.
- *Class C Chopper* can be used as a step-up or step-down chopper.

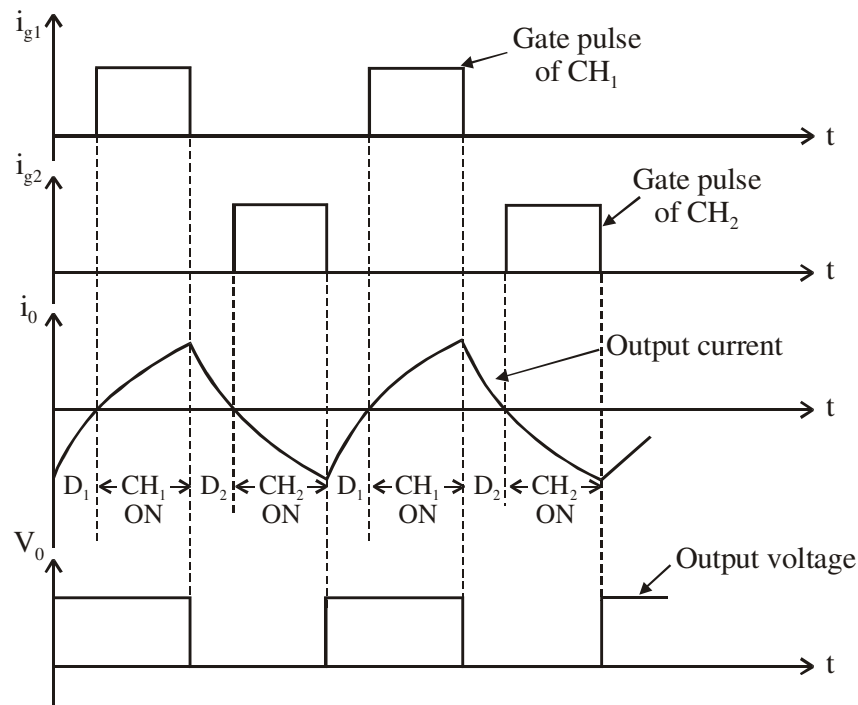

4. Class D Chopper

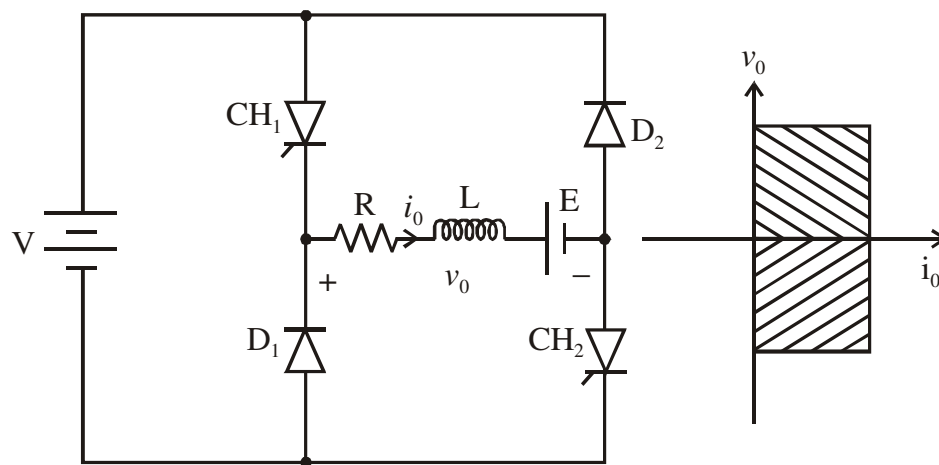

- Class D is a two quadrant chopper.
- When both CH_1 and CH_2 are triggered simultaneously, the output voltage $v_0 = V$ and output current flows through the load.
- When CH_1 and CH_2 are turned OFF, the load current continues to flow in the same direction through load, D_1 and D_2 , due to the energy stored in the inductor L .
- Output voltage $v_0 = -V$.
- Average load voltage is positive if chopper ON time is more than the OFF time
- Average output voltage becomes negative if $t_{ON} < t_{OFF}$.
- Hence the direction of load current is always positive but load voltage can be positive or negative.

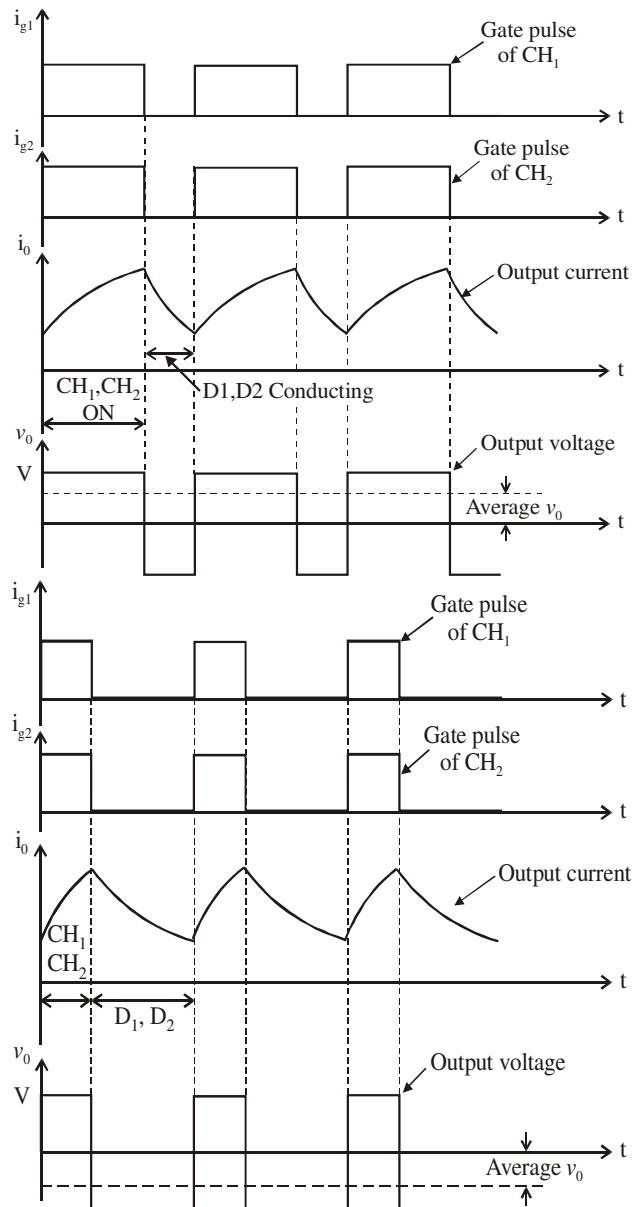

5. Class E Chopper

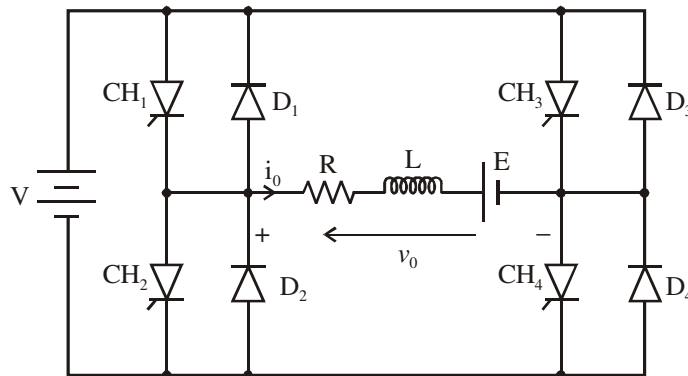

Four Quadrant Operation

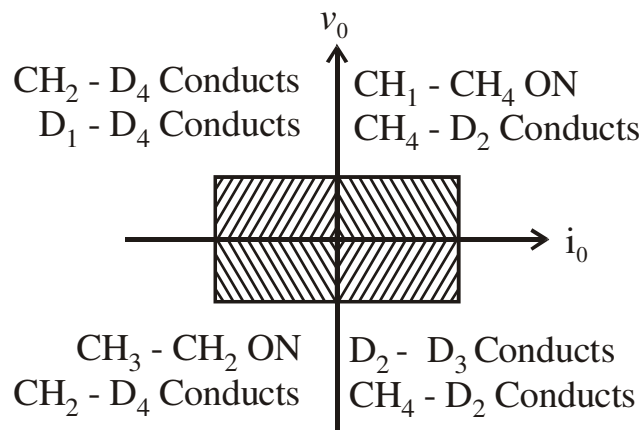

- Class E is a four quadrant chopper
- When $CH1$ and $CH4$ are triggered, output current i_o flows in positive direction through $CH1$ and $CH4$, and with output voltage $v_o = V$.
- This gives the first quadrant operation.
- When both $CH1$ and $CH4$ are OFF, the energy stored in the inductor L drives i_o through $D2$ and $D3$ in the same direction, but output voltage $v_o = -V$.
- Therefore the chopper operates in the fourth quadrant.
- When $CH2$ and $CH3$ are triggered, the load current i_o flows in opposite direction & output voltage $v_o = -V$.
- Since both i_o and v_o are negative, the chopper operates in third quadrant.
- When both $CH2$ and $CH3$ are OFF, the load current i_o continues to flow in the same direction $D1$ and $D4$ and the output voltage $v_o = V$.
- Therefore the chopper operates in second quadrant as v_o is positive but i_o is negative.

Effect Of Source & Load Inductance

- The source inductance should be as small as possible to limit the transient voltage.
- Also source inductance may cause commutation problem for the chopper.
- Usually an input filter is used to overcome the problem of source inductance.
- The load ripple current is inversely proportional to load inductance and chopping frequency.
- Peak load current depends on load inductance.
- To limit the load ripple current, a smoothing inductor is connected in series with the load.

7.5 Impulse Commutated Chopper

- Impulse commutated choppers are widely used in high power circuits where load fluctuation is not large.
- This chopper is also known as
 - Parallel capacitor turn-off chopper
 - Voltage commutated chopper

– Classical chopper.

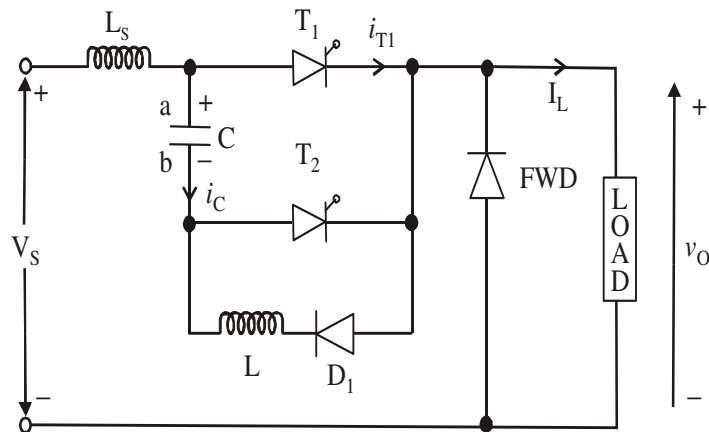

- To start the circuit, capacitor 'C' is initially charged with polarity (with plate 'a' positive) by triggering the thyristor T2.
- Capacitor 'C' gets charged through V_S , C, T2 and load.
- As the charging current decays to zero thyristor T2 will be turned-off.
- With capacitor charged with plate 'a' positive the circuit is ready for operation.
- Assume that the load current remains constant during the commutation process.
- For convenience the chopper operation is divided into five modes.
 - Mode-1
 - Mode-2
 - Mode-3
 - Mode-4
 - Mode-5

Mode-1 Operation

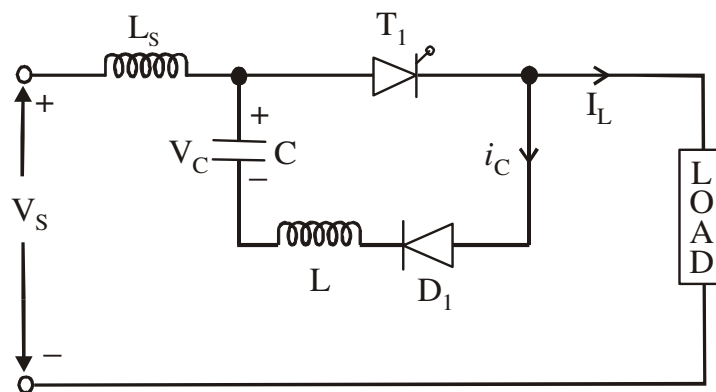

- Thyristor T1 is fired at $t = 0$.
- The supply voltage comes across the load.
- Load current I_L flows through T1 and load.
- At the same time capacitor discharges through T1, D1, L, & 'C' and the capacitor reverses its voltage.
- This reverse voltage on capacitor is held constant by diode D1.

Capacitor Discharge Current

$$i_c(t) = V \sqrt{\frac{C}{L}} \sin \omega t$$

Where $\omega = \frac{1}{\sqrt{LC}}$

& Capacitor Voltage

$$V_c(t) = V \cos \omega t$$

Mode-2 Operation

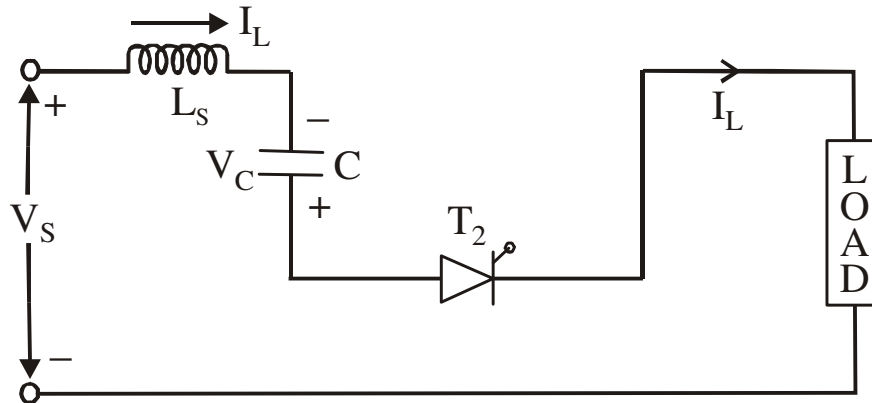

- Thyristor T_2 is now fired to commutate thyristor T_1 .
- When T_2 is ON capacitor voltage reverse biases T_1 and turns it off.
- The capacitor discharges through the load from $-V$ to 0 .
- Discharge time is known as circuit turn-off time
- Capacitor recharges back to the supply voltage (with plate 'a' positive).
- This time is called the recharging time and is given by

Circuit turn-off time is given by

$$t_c = \frac{V_c \times C}{I_L}$$

Where I_L is load current.

t_c depends on load current, it must be designed for the worst case condition which occurs at the maximum value of load current and minimum value of capacitor voltage.

- The total time required for the capacitor to discharge and recharge is called the commutation time and it is given by
- At the end of Mode-2 capacitor has recharged to V_S and the freewheeling diode starts conducting.

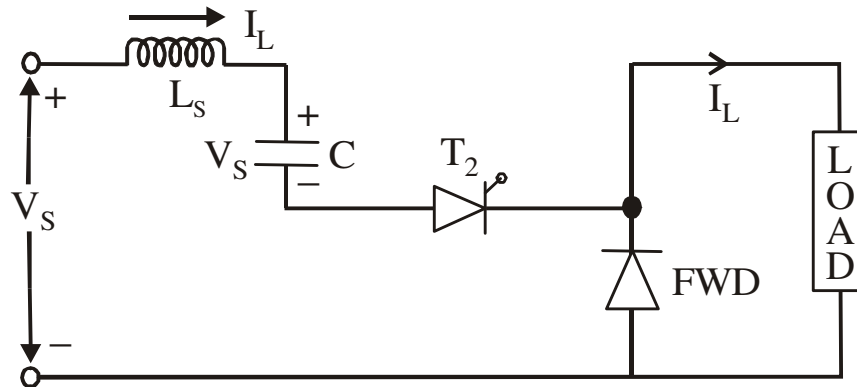
Mode-3 Operation

- *FWD* starts conducting and the load current decays.
- The energy stored in source inductance L_S is transferred to capacitor.
- Hence capacitor charges to a voltage higher than supply voltage, T_2 naturally turns off.

The instantaneous capacitor voltage is

$$V_C(t) = V_S + I_L \sqrt{\frac{L_S}{C}} \sin \omega_s t$$

Where

$$\omega_s = \frac{1}{\sqrt{L_S C}}$$

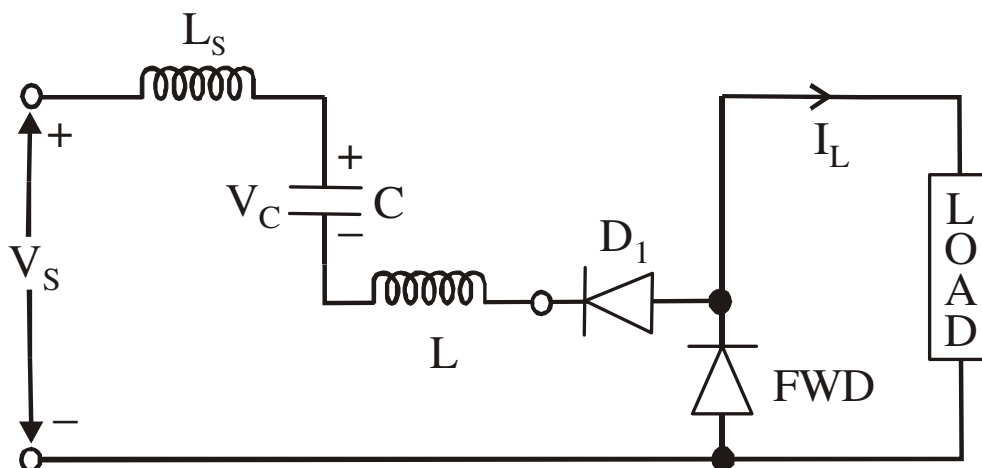
Mode-4 Operation

- Capacitor has been overcharged i.e. its voltage is above supply voltage.
- Capacitor starts discharging in reverse direction.
- Hence capacitor current becomes negative.
- The capacitor discharges through L_S , V_S , *FWD*, D_1 and L .

- When this current reduces to zero DI will stop conducting and the capacitor voltage will be same as the supply voltage.

Mode-5 Operation

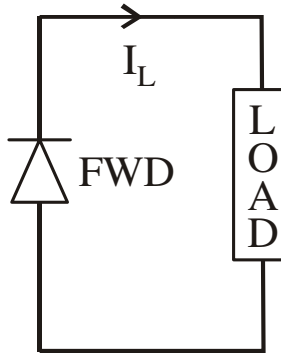

- Both thyristors are off and the load current flows through the FWD.
- This mode will end once thyristor $T1$ is fired.

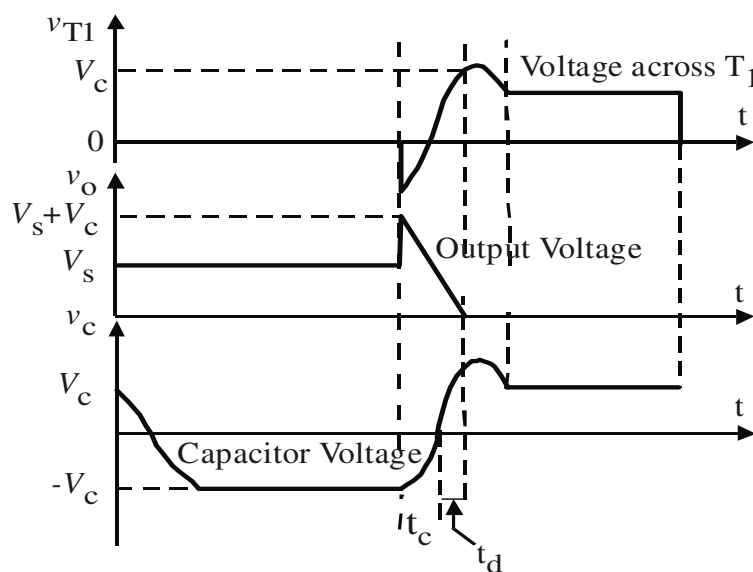
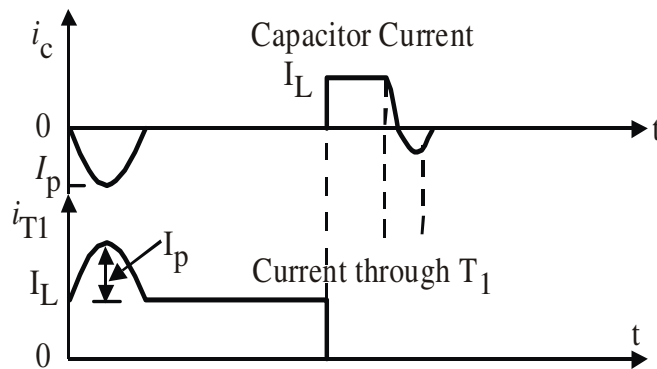

Disadvantages

- A starting circuit is required and the starting circuit should be such that it triggers thyristor $T2$ first.
- Load voltage jumps to almost twice the supply voltage when the commutation is initiated.
- The discharging and charging time of commutation capacitor are dependent on the load current and this limits high frequency operation, especially at low load current.
- Chopper cannot be tested without connecting load.

Thyristor $T1$ has to carry load current as well as resonant current resulting in increasing its peak current rating.

Recommended questions:

1. Explain the principle of operation of a chopper. Briefly explain time-ratio control and PWM as applied to chopper
2. Explain the working of step down chopper. Determine its performance factors, V_A , V_o rms, efficiency and R_i the effective input resistance
3. Explain the working of step down chopper for RLE load. Obtain the expressions for minimum load current $I_{1\text{min}}$, maximum load current I_2 , peak – peak load ripple current d_i avg value of load current I_a , the rms load current I_o and R_i .
4. Give the classification of step down converters. Explain with the help of circuit diagram one-quadrant and four quadrant converters.
5. The step down chopper has a resistive load of $R=10\Omega$ and the input voltage is $V_s=220V$. When the converter switch remains ON its voltage drop is $V_{ch}=2V$ and the chopping frequency is 1 KHz. If the duty cycle is 50% determine a) the avg output voltage V_A , b) the rms output voltage V_o c) the converter efficiency d) the effective input resistance R_i of the converter.
6. Explain the working of step-up chopper. Determine its performance factors.

UNIT-7

INVERTERS

The converters which convert the power into ac power popularly known as the inverters. The application areas for the inverters include the uninterruptible power supply (UPS), the ac motor speed controllers, etc.

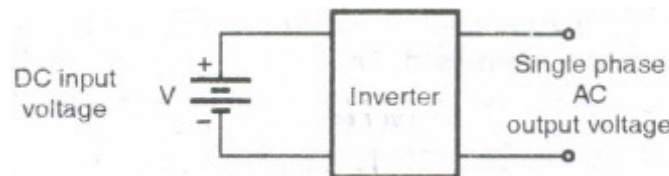

Fig.8.1 Block diagram of an inverter.

The inverters can be classified based on a number of factors like, the nature of output waveform (sine, square, quasi square, PWM etc), the power devices being used (thyristor transistor, MOSFETs IGBTs), the configuration being used, (series, parallel, half bridge, Full bridge), the type of commutation circuit that is being employed and Voltage source and current source inverters.

The thyristorised inverters use SCRs as power switches. Because the input source of power is pure dc in nature, forced commutation circuit is an essential part of thyristorised inverters. The commutation circuits must be carefully designed to ensure a successful commutation of SCRs. The addition of the commutation circuit makes the thyristorised inverters bulky and costly. The size and the cost of the circuit can be reduced to some extent if the operating frequency is increased but then the inverter grade thyristors which are special thyristors manufactured to operate at a higher frequency must be used, which are costly.

Typical applications

Un-interruptible power supply (UPS), Industrial (induction motor) drives, Traction, HVDC.

8.1 Classification of Inverters

There are different basis of classification of inverters. Inverters are broadly classified as current source inverter and voltage source inverters. Moreover it can be classified on the basis of devices used (SCR or gate commutation devices), circuit configuration (half bridge or full bridge), nature of output voltage (square, quasi square or sine wave), type of circuit (switched mode PWM or resonant converters) etc.

8.2 Principle of Operation:

1. The principle of single phase transistorised inverters can be explained with the help of Fig. 8.2. The configuration is known as the half bridge configuration.
2. The transistor Q_1 is turned on for a time $T_0/2$, which makes the instantaneous voltage across the load $V_o = V/2$.
3. If transistor Q_2 is turned on at the instant $T_0/2$ by turning Q_1 off then $-V/2$ appears across the load.

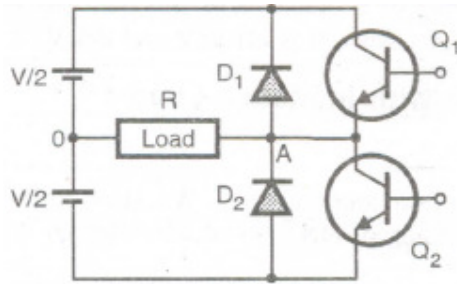

Fig.8.2 Half bridge inverter

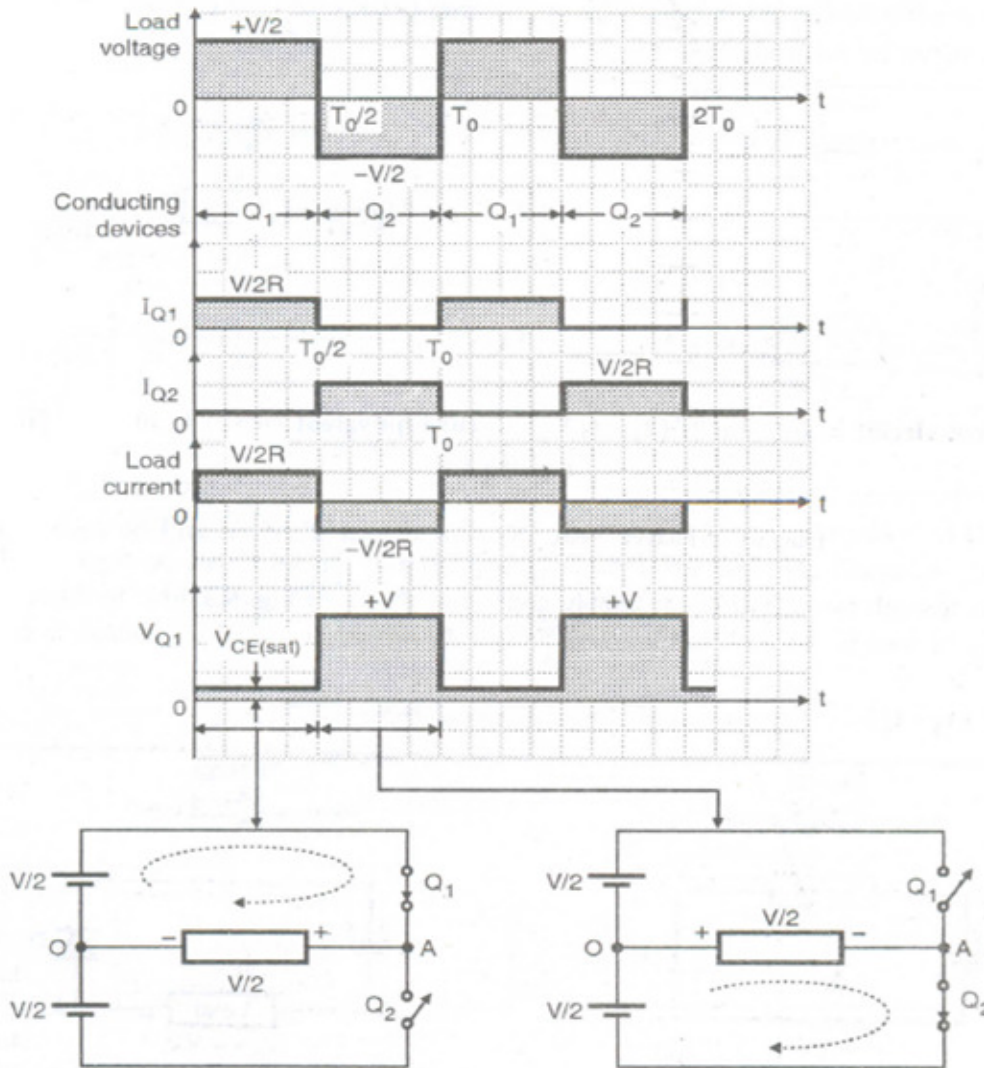

Fig. Load voltage and current waveforms with resistive load for half bridge inverter.

8.3 Half bridge inverter with Inductive load.

Operation with inductive load:

Let us divide the operation into four intervals. We start explanation from the second time interval II to t2 because at the beginning of this interval transistor Q1 will start conducting.

Interval II (t1 - t2): Q1 is turned on at instant t1, the load voltage is equal to + V/2 and the positive load current increases gradually. At instant t2 the load current reaches the peak

value. The transistor Q1 is turned off at this instant. Due to the same polarity of load voltage and load current the energy is stored by the load. Refer Fig. 8.3(a).

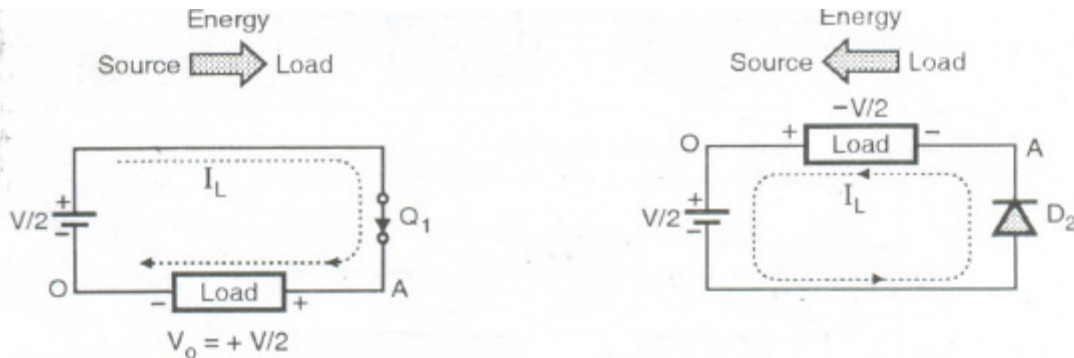

Fig.8.3 (a) circuit in interval II ($t_1 - t_2$) (b) Equivalent circuit in interval III ($t_2 - t_3$)

Interval III ($t_2 - t_3$): Due to inductive load, the load current direction will be maintained same even after Q1 is turned off. The self induced voltage across the load will be negative. The load current flows through lower half of the supply and D2 as shown in Fig. 8.3(b). In this interval the stored energy in load is fed back to the lower half of the source and the load voltage is clamped to $-V/2$.

Interval IV ($t_3 - t_4$):

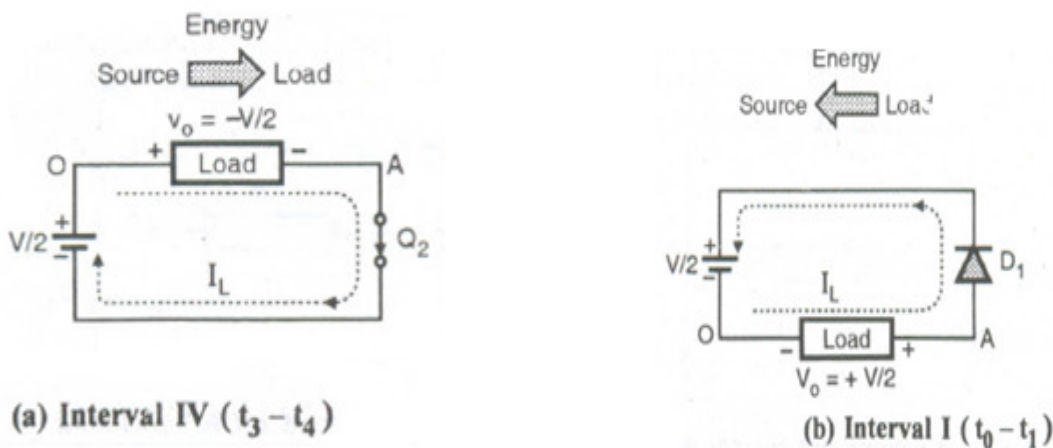

Fig.8.4

At the instant t_3 , the load current goes to zero, indicating that all the stored energy has been returned back to the lower half of supply. At instant t_3 ' Q2 'is turned on. This will produce a negative load voltage $v_0 = - V/2$ and a negative load current. Load current reaches a negative peak at the end of this interval. (See Fig. 8.4(a)).

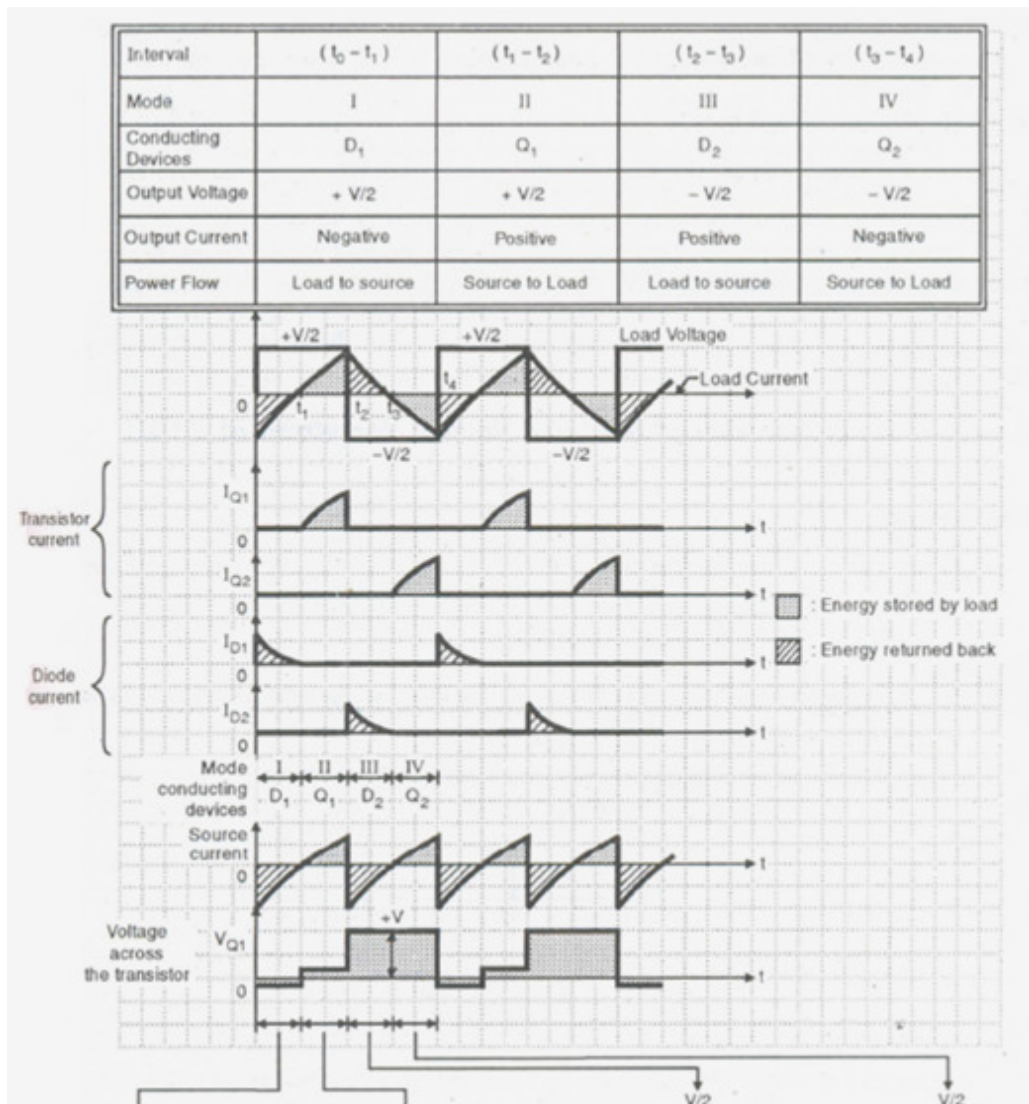

Fig.8.5: Current and voltage waveforms for half bridge inverter with RL load

Interval I (t_4 to t_5) or (t_0 to t_1)

Conduction period of the transistors depends upon the load power factor. For purely inductive load, a transistor conducts only for $T/2$ or 90° . Depending on the load power factor, that conduction period of the transistor will vary between 90 to 180° (180° for purely resistive load).

8.4 Fourier analysis of the Load Voltage Waveform of a Half Bridge Inverter

Assumptions:

- The load voltage waveform is a perfect square wave with a zero average value.
- The load voltage waveform does not depend on the type of load.
- a_n, b_n and c_n are the Fourier coefficients.
- θ_n is the displacement angle for the n th harmonic component of output voltage.
- Total dc input voltage to the inverter is V volts.

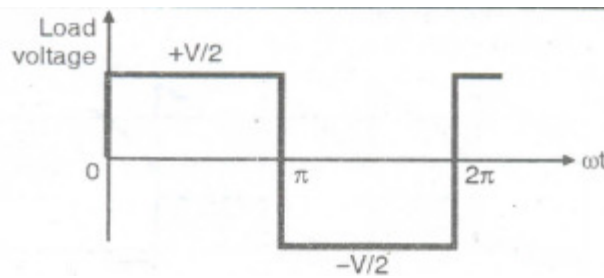

Fig.8.6

Refer to Fig. 8.6 . The instantaneous load voltage v_o can be expressed in the fourier series form as follows :

$$v_o = V_{o(av)} + \sum_{n=1}^{\infty} C_n \sin(n\omega t - \theta_n)$$

where $C_n = (a_n^2 + b_n^2)^{1/2}$ and $\theta_n = \tan^{-1} [a_n/b_n]$

The values of a_n and b_n can be found as follows :

Expression for a_n :

$$a_n = \frac{1}{\pi} \int_0^{2\pi} v_o(t) \cos n \omega t d \omega t$$

but $v_o(t) = +V/2,$ for $0 \leq \omega t \leq \pi$

and $v_o(t) = -V/2,$ for $\pi \leq \omega(t) \leq 2\pi$

$$\therefore a_n = \frac{1}{\pi} \left\{ \int_0^{\pi} (V/2) \cos n \omega t d \omega t - \int_{\pi}^{2\pi} (V/2) \cos n \omega t d \omega t \right\}$$

$$= \frac{V}{2\pi n} [\sin n \pi - \sin 0] - \frac{V}{2\pi n} [\sin 2\pi n - \sin \pi n]$$

$$\therefore a_n = 0 \text{ for all value of } n.$$

Expression for b_n :

$$\begin{aligned}
 b_n &= \frac{1}{\pi} \int_0^{2\pi} v_o(t) \sin n\omega t \, d\omega t \\
 b_n &= \frac{1}{\pi} \left\{ \int_0^{\pi} (V/2) \sin n\omega t \, d\omega t - \int_{\pi}^{2\pi} (V/2) \sin n\omega t \, d\omega t \right\} \\
 &= \frac{-V}{2\pi n} [\cos n\pi - \cos 0] + \frac{V}{2\pi n} [\cos 2\pi n - \cos \pi n] \\
 &= \frac{-V}{2\pi n} [\cos n\pi - 1] + \frac{V}{2\pi n} [1 - \cos n\pi] \\
 &= \frac{V}{2\pi n} [1 - \cos n\pi + 1 - \cos n\pi] \\
 \therefore b_n &= \frac{V}{\pi n} [1 - \cos n\pi]
 \end{aligned}$$

But $\cos n\pi = +1$ for $n = 2, 4, 6, \dots$ i.e. for n even.

$\therefore b_n = 0$ for even values of n

and $\cos n\pi = -1$ for $n = 1, 3, 5, \dots$ i.e. for n odd

$\therefore b_n = \frac{2V}{n\pi}$ for odd values of n

Expression for C_n :

$$c_n = b_n = \frac{2V}{n\pi}$$

This is the peak amplitude of n^{th} harmonic component of the output voltage and
 $\theta_n = \tan^{-1} 0 = 0$

and $V_o(\text{av}) = 0$

Therefore the instantaneous output voltage of a half bridge inverter can be expressed In Fourier series form as,

$$\begin{aligned}
 v_o(t) &= \sum_{n=1,3,5,\dots}^{\infty} \frac{2V}{n\pi} \sin n\omega t \\
 &= 0 \quad \text{for even values of } n.
 \end{aligned}$$

Equation indicates that the frequency spectrum of the output voltage waveform consists of only odd order harmonic components. i.e. 1,3,5,7etc. The even order harmonics are automatically cancelled out.

RMS output voltage

$$V_{o\text{ rms}} = \left\{ \frac{1}{\pi} \int_0^{\pi} (V/2)^2 d\omega t \right\}^{1/2}$$

$$= \left\{ \frac{V^2}{4\pi} \times \pi \right\}^{1/2}$$

$$V_{o\text{ rms}} = \frac{V}{2} \text{ volts}$$

RMS value of fundamental component of output voltage

In order to find the value of fundamental component of output voltage substitute $n = 1$ in the above equation

$$\text{we get } V_{o1(\text{peak})} = \frac{2V}{\pi}$$

As the fundamental component is a sinewave, its rms value is given by,

$$V_{o1\text{ rms}} = \frac{2V}{\sqrt{2}\pi} = \frac{\sqrt{2}V}{\pi} = 0.45V$$

8.5 Performance parameters of inverters

The output of practical inverters contains harmonics and the quality of an inverter is normally evaluated in terms of following performance parameters:

- Harmonic factor of n^{th} harmonic.
- Total harmonic distortion.
- Distortion factor.
- Lowest order harmonic.

Harmonic factor of n^{th} harmonics HF_n :

The harmonic factor is a measure of contribution of individual harmonics. It is defined as the ratio of the rms voltage of a particular harmonic component to the rms value of fundamental component.

$$HF_n = \frac{V_{on\text{ rms}}}{V_{o1\text{ rms}}}$$

Where $V_{on\text{ rms}}$ = Rms value of the n^{th} harmonic of output voltage.

and $V_{o1\text{ rms}}$ = Rms value of the fundamental component.

Total Harmonic Distortion

The total harmonic distortion is a measure of the total amplitude of the harmonics present in the output of inverter except the fundamental component. In other words it is the measure of closeness in shape between a waveform and its fundamental component.

The THD defined as,

$$\begin{aligned} \text{THD} &= \frac{1}{V_{o1 \text{ rms}}} \left(\sum_{n=2,3,\dots}^{\infty} V_{on \text{ rms}}^2 \right)^{1/2} \\ &= \frac{1}{V_{o1 \text{ rms}}} \left[V_2^2 + V_3^2 + V_4^2 + \dots \right]^{1/2} \end{aligned}$$

where V_2, V_3, \dots are the rms voltages at second, third harmonic frequencies. THD thus gives the total harmonic content.

Distortion Factor DF

THD gives the total harmonic content but it does not indicate the level of each harmonic component.

If a filter is used at the output of the inverter, the higher order harmonics would be attenuated more effectively. Therefore a knowledge of both the frequency and the magnitude of each harmonic is important.

The distortion factor indicates the amount of harmonic distortion that remains in a particular waveform after the harmonics of that waveform have been subjected to a second order attenuation. (i.e. divided by n^2).

Thus DF is a measure of effectiveness in reducing the unwanted harmonics without having to specify the values of a second order load filter. DF is defined as

$$\begin{aligned} \text{DF} &= \frac{1}{V_{o1 \text{ rms}}} \left[\sum_{n=2,3,\dots}^{\infty} \left(V_{on \text{ rms}} / n^2 \right)^2 \right]^{1/2} \\ \therefore \text{DF} &= \frac{1}{V_{o1 \text{ rms}}} \left[(V_2 / 2^2)^2 + (V_3 / 3^2)^2 + (V_4 / 4^2)^2 + \dots \right]^{1/2} \end{aligned}$$

Lowest order Harmonic

The lowest order harmonic is that harmonic component whose frequency is the closest to the fundamental one and its amplitude is greater than or equal to 3 % of the fundamental component.

8.6 Single Phase Bridge Inverter

A single phase bridge inverter is shown in Fig.8.7. It consists of four transistors. These transistors are turned on and off in pairs of Q1, Q2 and Q3 Q4.

In order to develop a positive voltage $+V$ across the load, the transistors Q1, and Q2 are turned on simultaneously whereas to have a negative voltage $-V$ across the load we need to turn on the devices Q3 and Q4.

Diodes D1, D2, D3, and D4 are known as the feedback diodes, because energy feedback takes place through these diodes when the load is inductive.

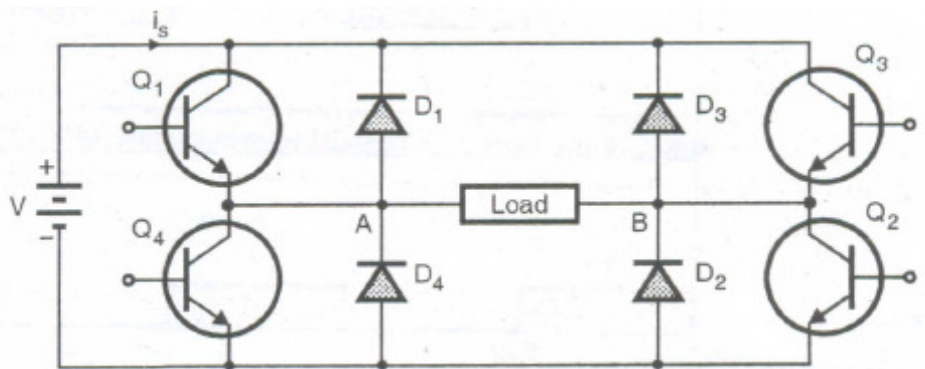

Fig.8.7: single phase full bridge inverter

Operation with resistive load

With the purely resistive load the bridge inverter operates in two different intervals. In one cycle of the output.

Mode I (0 - $T_0/2$):

The transistors Q1 and Q2 conduct simultaneously in this mode. The load voltage is $+V$ and load current flows from A to B. The equivalent circuit for mode 1 is as shown in Fig. 8.8 (A). At $t = T_0/2$, Q1 and Q2 are turned off and Q3 and Q4 are turned on.

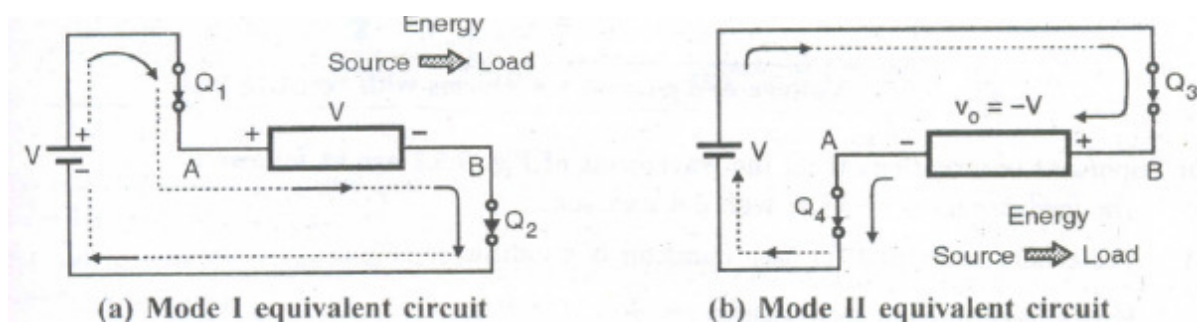

Fig.8.8

Mode II ($T_0/2 - T_0$):

- At $t = T_0/2$, Q3 and Q4 are turned on and Q1 and Q2 are turned off. The load voltage is $-V$

and load current flows from B to A. The equivalent circuit for mode II is as shown in Fig. 9.5.1(b). At $t = T_0$, Q3 and Q4 are turned off and Q1 and Q2 are turned on again.

- As the load is resistive it does not store any energy. Therefore the feedback diodes are not effective here.
- The voltage and current waveforms with resistive load are as shown in Fig. 9.5.2.

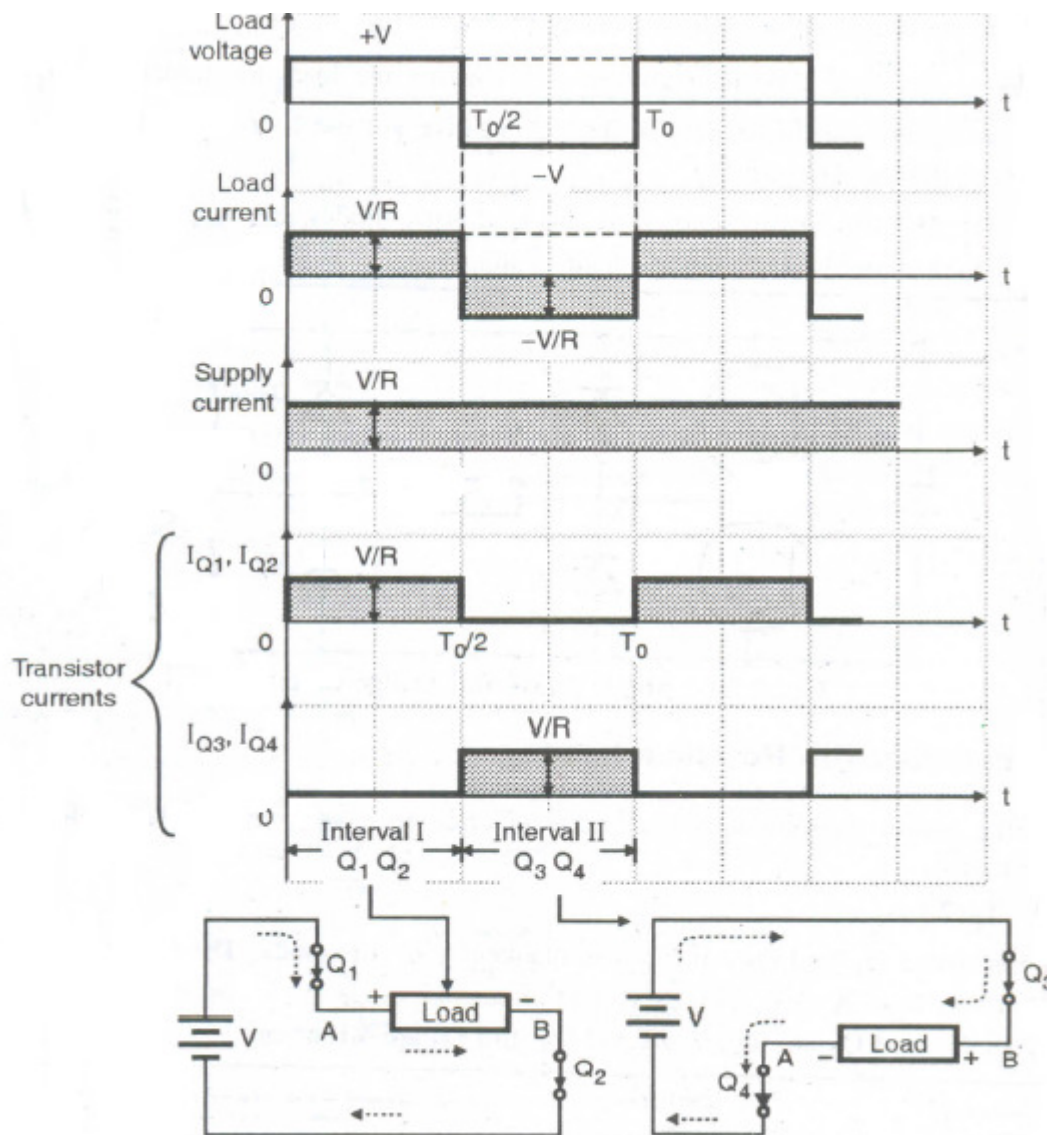

Fig.8.10:Voltage and current waveforms with resistive load.

The important observations from the waveforms of Fig. 8.10 are as follows:

- The load current is in phase with the load voltage
- The conduction period for each transistor is $1t$ radians or 180°
- Peak current through each transistor = V/R .
- Average current through each transistor = $V/2R$
- Peak forward voltage across each transistor = V volts.

8.7 Single Phase Bridge Inverter with RL Load

The operation of the circuit can be divided into four intervals or modes. The waveforms are as shown in Fig. 8.13.

Interval I ($t_1 - t_2$):

At instant t_1 , the pair of transistors Q_1 and Q_2 is turned on. The transistors are assumed to be ideal switches. Therefore point A gets connected to positive point of dc source V through Q_1 , and point B gets connected to negative point of input supply.

The output voltage $V_o = +V$ as shown in Fig 8.11(a). The load current starts increasing exponentially due to the inductive nature of the load.

The instantaneous current through Q_1 and Q_2 is equal to the instantaneous load current. The energy is stored into the inductive load during this interval of operation.

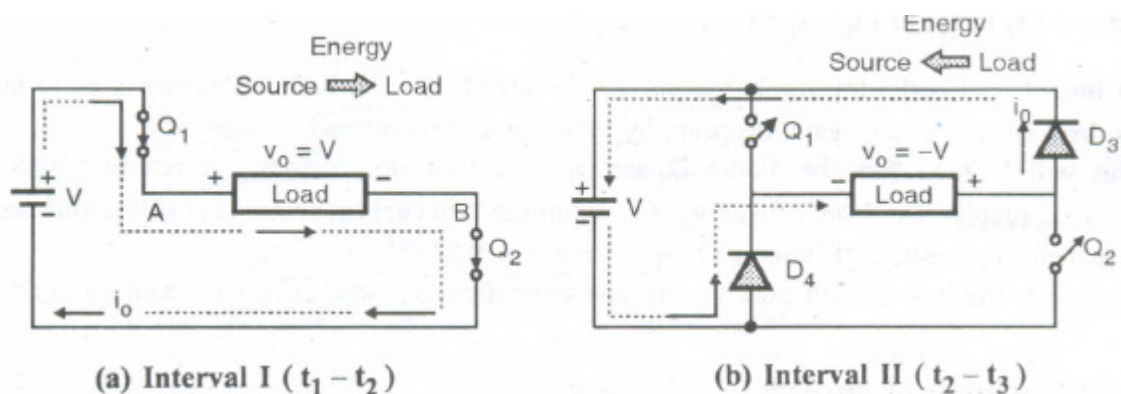

Fig.8.11

Interval II ($t_2 - t_3$):

- At instant t_2 both the transistors Q_1 and Q_2 are turned off. But the load current does not reduce to 0 instantaneously, due to its inductive nature.
- So in order to maintain the flow of current in the same direction there is a self induced voltage across the load. The polarity of this voltage is exactly opposite to that in the previous mode.
- Thus output voltage becomes negative equal to $-V$. But the load current continues to now in the same direction, through D_3 and D_4 as shown in Fig. 8.11(b).
- Thus the stored energy in the load inductance is returned back to the source in this mode. The diodes D_1 to D_4 are therefore known as the feedback diodes.
- The load current decreases exponentially and goes to 0 at instant t_3 when all the energy stored in the load is returned back to supply. D_3 and D_4 are turned off at t_3 .

Interval III ($t_3 - t_4$)

- At instant t_3 Q_3 and Q_4 are turned on simultaneously. The load voltage remains negative equal to $-V$ but the direction of load current will reverse and become negative.
- The current increases exponentially in the negative direction. And the load again stores energy in this mode of operation. This is as shown in Fig. 8.12(a).

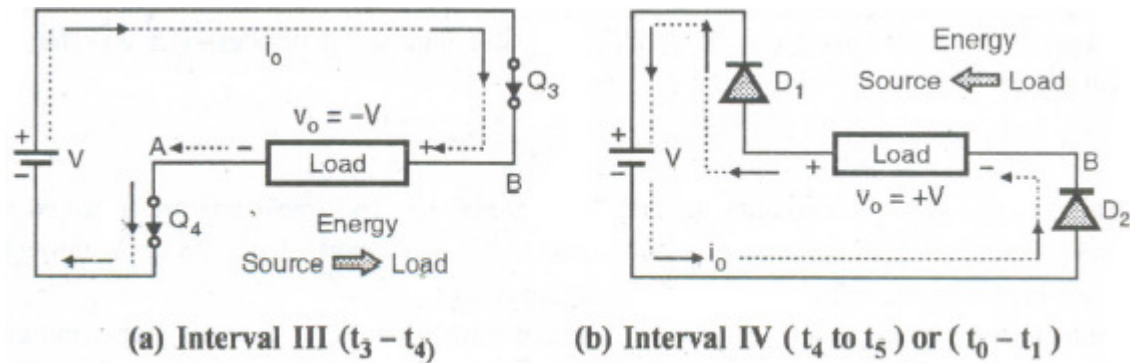

Fig.8.12

Interval IV (t_4 to t_5) or (t_0 to t_1)

- At instant t_4 or to the transistors Q_3 and Q_4 are turned off. The load inductance tries to maintain the load current in the same direction, by inducing a positive load voltage.
- This will forward bias the diodes D_1 and D_2 . The load stored energy is returned back to the input dc supply. The load voltage $V_o = +V$ but the load current remains negative and decrease exponentially towards 0. This is as shown in Fig. 8.12(b).
- At t_5 or t_1 the load current goes to zero and transistors Q_1 and Q_2 can be turned on again.

Conduction period of devices:

- The conduction period with a very highly inductive load, will be T_{014} or 90° for all the transistors as well as the diodes.
- The conduction period of transistors will increase towards T_{02} or 180° with increase in the load power factor. (i.e., as the load becomes more and more resistive).

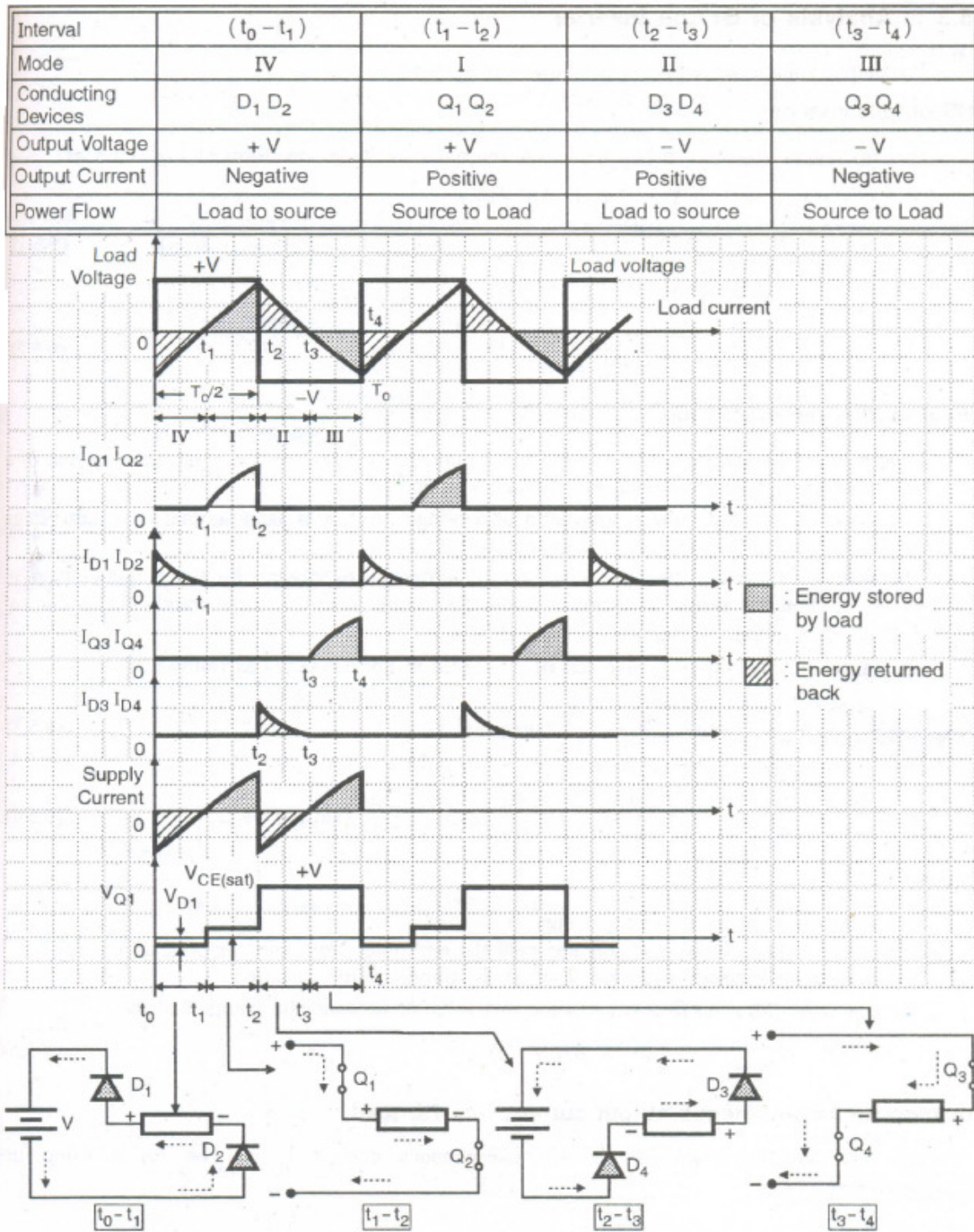

Fig.8.13. voltage and current waveforms for single phase bridge inverter with RL load.

Analysis of Bridge Inverter :

The output voltage waveform is as shown in Fig. 8.13 .

RMS output voltage :

The rms output voltage can be found from the output voltage waveform of Fig. 8.13 as

$$V_{o \text{ rms}} = \left[\frac{1}{T_0/2} \int_0^{T_0/2} V^2 dt \right]^{1/2}$$

$$\therefore V_{o \text{ rms}} = \left[\frac{2V^2}{T_0} \left(\frac{T_0}{2} - 0 \right) \right]^{1/2} = V \text{ volts}$$

Fourier series representation :

1. Fourier series for output voltage of full bridge inverter is found on the same lines as that of a half bridge inverter discussed in the previous section.
2. The shape of the load voltage waveform of a bridge inverter is same as that of a half bridge circuit, except for the value of peak output voltage.
3. The peak output voltage is "V" volts here therefore the expression for the output voltage in terms of Fourier series is expressed on the same lines, i.e. substitute the value of instantaneous output voltage as + V instead of + V / 2.
4. The instantaneous output voltage can be expressed in Fourier series as follows :

$$v_o(\omega t) = \sum_{n=1,3,5,\dots}^{\infty} \frac{4V}{n\pi} \sin n\omega t$$

That means
$$v_o(\omega t) = \left(\frac{4V}{\pi} \sin \omega t + \frac{4V}{3\pi} \sin 3\omega t + \frac{4V}{5\pi} \sin 5\omega t + \dots \right)$$

Conclusion :

This equation indicates following things :

- (1) The output voltage waveform contains only the odd order harmonic components i.e. 3,5,7..... . The even order harmonics (i.e n = 2,4,6...) are automatically cancelled.

In this equation $Z_n = \sqrt{R^2 + (n\omega L)^2}$ is the impedance offered by the load to the n^{th} harmonic component and $\frac{4V}{n\pi}$ is the peak amplitude of n^{th} harmonic voltage.

$$\text{And } \theta_n = \tan^{-1}(n\omega L/R)$$

Prob 1 A single phase half bridge inverter has a resistive load of $R = 3 \Omega$ and the dc input voltage $V = 24$ volts. Determine

- The rms output voltage at the fundamental frequency, V_1
- The output power P_o
- The average and peak currents of each transistor.
- The peak reverse blocking voltage V_{BR} for each transistor.
- Total harmonic distortion THD
- The distortion factor DF
- The harmonic factor and the distortion factor of the lowest order harmonic.

Soln. :

Data $V = 24$ volts. $R = 3 \Omega$

- (i) The rms output voltage at fundamental frequency = $V_{1 \text{ rms}}$

$$= \frac{2V}{\sqrt{2}\pi} = 10.8 \text{ volts.}$$

$$V_{1 \text{ rms}} = 10.8 \text{ volts.}$$

- (ii) The output power :

$$P_o = V_o^2/R \text{ and } V_o = V/2$$

where $V_o =$ rms output voltage.

$$\therefore P_o = (12)^2/3 = 48 \text{ watt.}$$

$$P_o = 48 \text{ watt}$$

- (iii) The average and peak current of each transistor.

The average current

$$I_{T(av)} = \frac{1}{T} \int_0^{T/2} \frac{V}{2R} dt = \frac{V}{2RT} (T/2) = \frac{V}{4R}$$

\therefore average transistor current

$$I_{T(av)} = 24/3 \times 4$$

$$I_{T(av)} = 2 \text{ Amp}$$

The transistor peak current

$$= I_{T(peak)} = \frac{V/2}{R} = 4 \text{ Amp}$$

- (iv) Peak reverse blocking voltage
- V_{BR}
- for each transistor.

$$V_{BR} = 2 \times \frac{V}{2} = 24 \text{ volts.}$$

- (v) Total harmonic distortion (THD)

$$\text{THD} = \frac{1}{V_{1 \text{ rms}}} \left(\sum_{n=2,3}^{\infty} V_{n \text{ rms}}^2 \right)^{1/2}$$

$$V_{o1 \text{ rms}} = 10.8 \text{ volts as already calculated in (i)}$$

The rms harmonic voltage

$$\begin{aligned} &= \left[\sum_{n=3,5,7,\dots}^{\infty} V_{n \text{ rms}}^2 \right]^{1/2} \\ &= (V_o^2 - V_{o1 \text{ rms}}^2)^{1/2} = [12^2 - (10.8)^2]^{1/2} = 5.23 \text{ volts.} \end{aligned}$$

$$\text{THD} = 5.23/10.8 = 0.484 = 48.4 \%$$

- (vi) The distortion factor DF

$$= \frac{1}{V_{o1 \text{ rms}}} \left[\sum_{n=3,5,7}^{\infty} \left(\frac{V_{on \text{ rms}}}{n^2} \right)^2 \right]^{1/2}$$

to find $\frac{V_{on \text{ rms}}}{n^2}$ we have to find $V_{n \text{ rms}}$ first

$$v_o = \sum_{n=1,3,5}^{\infty} \frac{2V}{n\pi} \sin n\omega t = 0, \text{ for, } n = 2,4,6;$$

$$\therefore v_o = \frac{2V}{\pi} \sin \omega t + \frac{2V}{3\pi} \sin 3\omega t + \frac{2V}{5\pi} \sin 5\omega t + \frac{2V}{7\pi} \sin 7\omega t + \dots$$

$$V_{3 \text{ rms}} = \frac{2V}{3\pi\sqrt{2}} = 3.6 \text{ volts.} \quad V_{5 \text{ rms}} = \frac{2V}{5\pi\sqrt{2}} = 2.16 \text{ volts.}$$

$$V_{7 \text{ rms}} = 1.54 \text{ volts.} \quad V_{9 \text{ rms}} = 1.2 \text{ volts.}$$

$$V_{11 \text{ rms}} = 0.982 \text{ volts.} \quad V_{13 \text{ rms}} = 0.83 \text{ volts.}$$

$$\begin{aligned} \therefore \left[\sum_{n=3,5,7}^{\infty} (V_{n \text{ rms}}^2/n^2) \right]^{1/2} &= \left[(V_3/3^2)^2 + (V_5/5^2)^2 + (V_7/7^2)^2 + \dots \right]^{1/2} \\ &= \left[0.16 + 0.0348 + 2.3 \times 10^{-3} + \dots \right]^{1/2} = 0.44 \text{ volts.} \end{aligned}$$

$$\therefore DF = 0.44/10.8 = 0.041 \qquad DF = 4.1 \%$$

(vii) The lowest harmonic is third harmonic

$$\begin{aligned} \therefore HF \text{ for the third harmonic} &= HF_3 = V_{3 \text{ rms}}/V_{1 \text{ rms}} \\ &= 3.6/10.8 = 33.33\% \end{aligned}$$

$$\begin{aligned} DF \text{ the third harmonic } DF_3 &= (V_{3 \text{ rms}}/3^2)/V_{1 \text{ rms}} \\ &= (3.6/9)/10.8 = 0.037 \text{ or } 3.7\% \end{aligned}$$

8.8 Comparison of half bridge and full bridge inverters

Sr. No.	Parameter	Half bridge	Full bridge
1	Need of an output transformer	Not needed	Not needed
2	Number of transistors required to be used.	Two	Four
3	Efficiency	High	High
4	Voltage across the nonconducting transistor	V Volts	V Volts
5	Output voltage waveform	Square, Quasi square or PWM	Square, Quasi square or PWM
6	Current rating of power device	Equal to the load current	Equal to the load current
7	Number of devices conducting simultaneously	One	Two
8	Necessity of dead band to avoid cross conduction	Yes	Yes

8.9 Principle of Operation of CSI:

The circuit diagram of current source inverter is shown in Fig. 8.14. The variable dc voltage source is converted into variable current source by using inductance L.

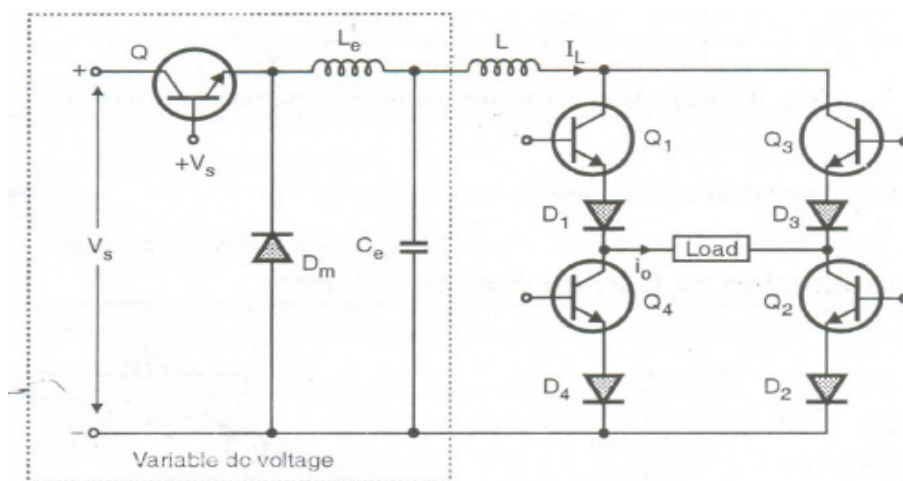

Fig.8.14. CSI using Thyristor

The current I_L supplied to the single phase transistorised inverter is adjusted by the combination of variable dc voltage and inductance L .

The waveforms of base currents and output current i_o are as shown in Fig. 8.15. When transistors Q_1 and Q_2 conduct simultaneously, the output current is positive and equal to $+I_L$. When transistors Q_3 and Q_4 conduct simultaneously the output current $i_o = -I_L$. But $i_o = 0$ when the transistors from same arm i.e. Q_1 or Q_2 or Q_3 or Q_4 conduct simultaneously.

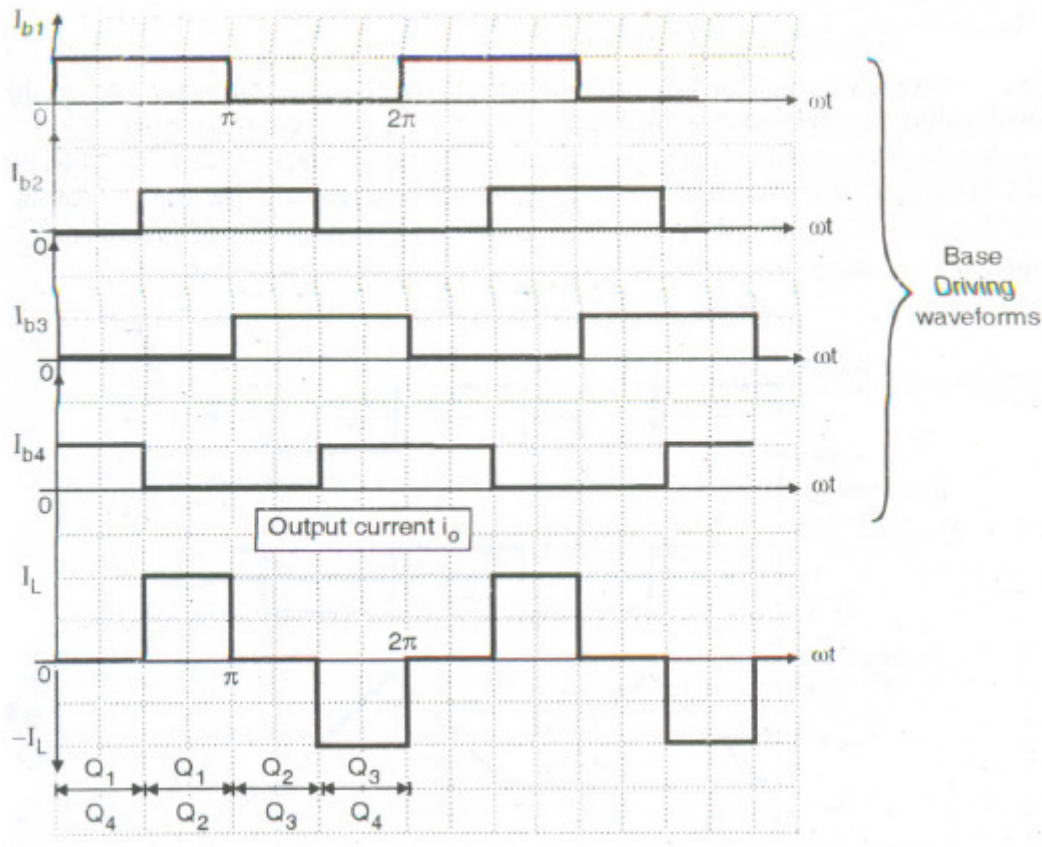

Fig.8.15: Waveforms for single phase current source

The output current waveform of Fig. 8.15 is a quasi-square waveform. But it is possible to Obtain a square wave load current by changing the pattern of base driving signals. Such waveforms are shown in Fig. 8.16.

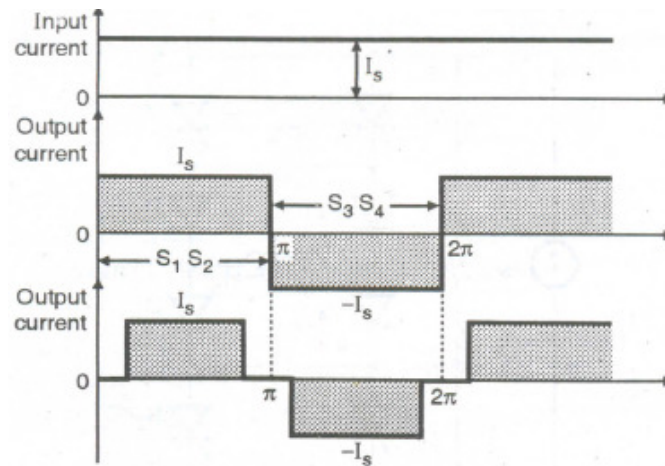

Fig.8.16 Waveforms

Load Voltage:

- The load current waveform in CSI has a defined shape, as it is a square waveform in this case. But the load voltage waveform will be dependent entirely on the nature of the load.
- The load voltage with the resistive load will be a square wave, whereas with a highly inductive load it will be a triangular waveform. The load voltage will contain frequency components at the inverter frequency f , equal to $1/T$ and other components at multiples of inverter frequency.
- The load voltage waveforms for different types of loads are shown in Fig. 8.17.

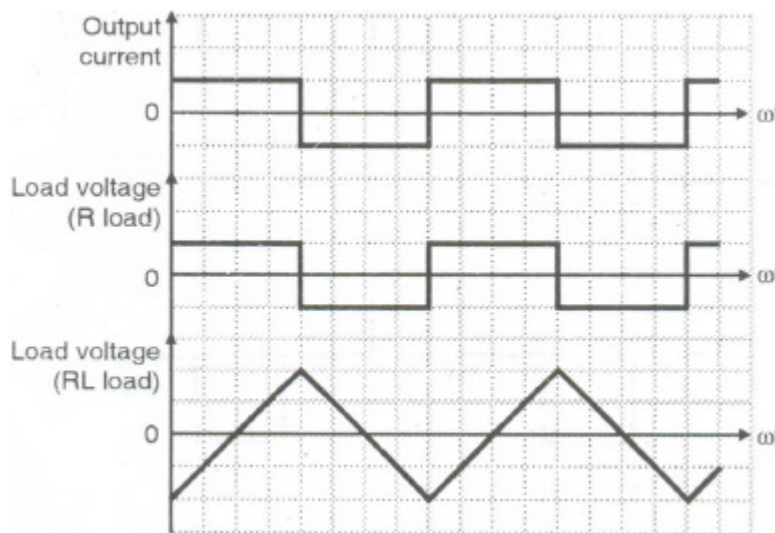

Fig.8.17 Load voltage waveforms for different types of loads

8.10 Variable DC link Inverter

The circuit diagram of a variable DC-link inverter is shown in Fig.8.18. This circuit can be divided into two parts namely a block giving a variable DC voltage and the second part being the bridge inverter itself.

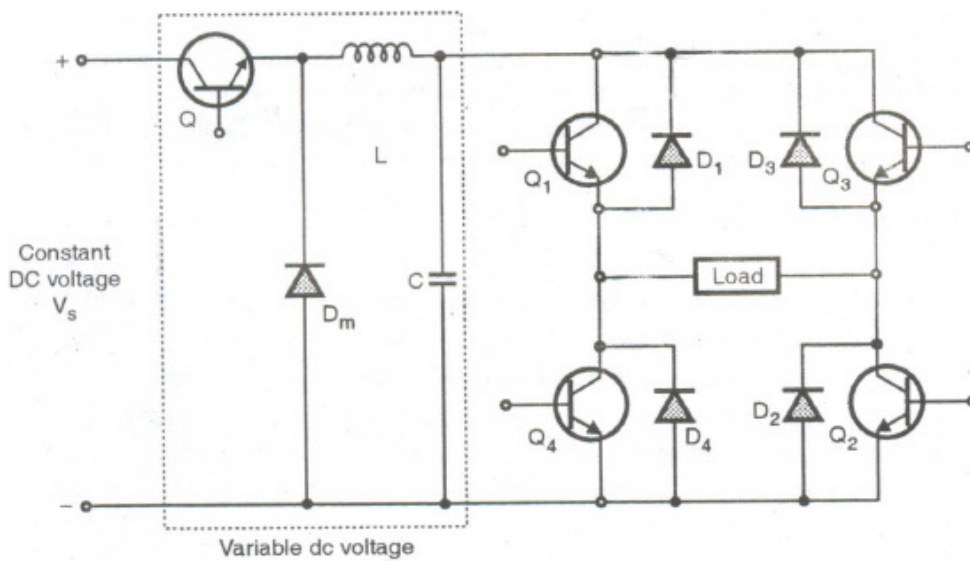

Fig.8.18. Variable DC link Inverter

The components Q, D_m, L and C give out a variable DC output. L and C are the filter components. This variable DC voltage acts as the supply voltage for the bridge inverter.

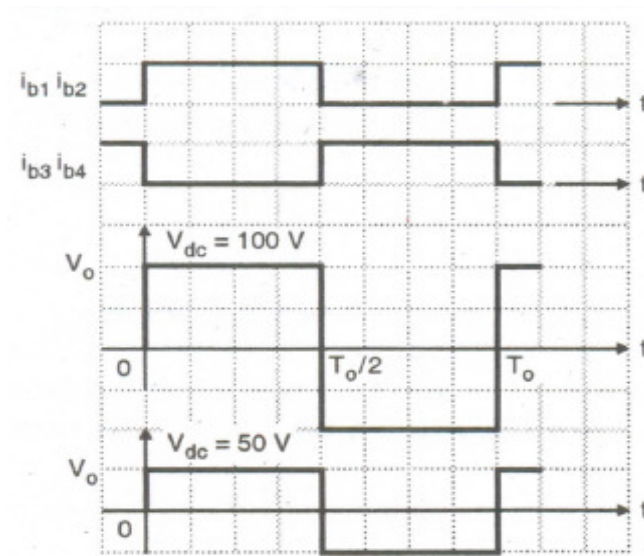

Fig.8.19. Output voltage Waveforms for different DC input voltages

The pulse width (conduction period) of the transistors is maintained constant and the variation in output voltage is obtained by varying the DC voltage.

The output voltage waveforms with a resistive load for different dc input voltages are shown in Fig. 8.19.

We know that for a square wave inverter, the rms value of output voltage is given by,

$$V_0 (\text{rms}) = V_{dc} \text{ volts}$$

Hence by varying V_{dc} , we can vary V_0 (rms)

One important advantage of variable DC link inverters is that it is possible to eliminate or reduce certain harmonic components from the output voltage waveform.

The disadvantage is that an extra converter stage is required to obtain a variable DC voltage from a fixed DC. This converter can be a chopper.

- Prob 2** : The 1 ϕ half bridge inverter using transistors has a resistive load of 2Ω . The DC supply is 24V. Calculate :
- RMS output voltage at fundamental frequency
 - Output power
 - Average and peak current
 - Peak reverse blocking voltage of each transistor.

Soln. :

- (i) Refer to Equation (9.3.12)

\therefore RMS output voltage at fundamental frequency is given by,

$$\begin{aligned} V_{o1 \text{ rms}} &= 0.45 \times V = 0.45 \times 24 \\ &= 10.8 \text{ volts} \end{aligned}$$

- (ii) Output power = $V_{o \text{ rms}}^2 / R$ But $V_{o \text{ rms}} = V/2 = 12$ volts

$$\therefore \text{Output power} = (12)^2 / 2 = 72 \text{ watt}$$

- (iii) Peak load current = $\frac{V}{2R} = \frac{24}{4}$
= 6 Amp

- (iv) Average load current = 0

- (v) Peak reverse blocking voltage of each transistor = $V = 24$ volts.

Recommended questions:

1. What are the differences between half and full bridge inverters?
2. What are the purposes of feedback diodes in inverters?
3. What are the arrangements for obtaining three phase output voltages?
4. What are the methods for voltage control within the inverters?
5. What are the methods of voltage control of I-phase inverters? Explain them briefly.
6. What are the main differences between VSI and CSI?
7. With a neat circuit diagram, explain single phase CSI?
8. The single phase half bridge inverter has a resistive load of $R= 2.4 \Omega$ and the dc input voltage is $V_s=48V$ Determine a) the rms output voltage at the fundamental frequency V_{o1} b) The output power P_o c) the average and peak currents of each transistor d) the peak reverse blocking voltage V_{br} of each transistor e) the THD f) the DF g) the HF and DF of the LOH.

Unit-8

AC VOLTAGE CONTROLLER CIRCUITS

AC voltage controllers (ac line voltage controllers) are employed to vary the RMS value of the alternating voltage applied to a load circuit by introducing Thyristors between the load and a constant voltage ac source. The RMS value of alternating voltage applied to a load circuit is controlled by controlling the triggering angle of the Thyristors in the ac voltage controller circuits.

In brief, an ac voltage controller is a type of thyristor power converter which is used to convert a fixed voltage, fixed frequency ac input supply to obtain a variable voltage ac output. The RMS value of the ac output voltage and the ac power flow to the load is controlled by varying (adjusting) the trigger angle ' α '

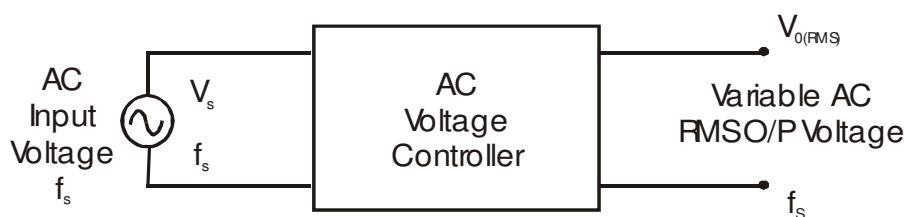

There are two different types of thyristor control used in practice to control the ac power flow

- On-Off control
- Phase control

These are the two ac output voltage control techniques.

In On-Off control technique Thyristors are used as switches to connect the load circuit to the ac supply (source) for a few cycles of the input ac supply and then to disconnect it for few input cycles. The Thyristors thus act as a high speed contactor (or high speed ac switch).

6.1 Phase Control

In phase control the Thyristors are used as switches to connect the load circuit to the input ac supply, for a part of every input cycle. That is the ac supply voltage is chopped using Thyristors during a part of each input cycle.

The thyristor switch is turned on for a part of every half cycle, so that input supply voltage appears across the load and then turned off during the remaining part of input half cycle to disconnect the ac supply from the load.

By controlling the phase angle or the trigger angle ' α ' (delay angle), the output RMS voltage across the load can be controlled.

The trigger delay angle ' α ' is defined as the phase angle (the value of ωt) at which the thyristor turns on and the load current begins to flow.

Thyristor ac voltage controllers use ac line commutation or ac phase commutation. Thyristors in ac voltage controllers are line commutated (phase commutated) since the input supply is ac. When the input ac voltage reverses and becomes negative during the negative half cycle the current flowing through the conducting thyristor decreases and falls to zero. Thus the ON thyristor naturally turns off, when the device current falls to zero.

Phase control Thyristors which are relatively inexpensive, converter grade Thyristors which are slower than fast switching inverter grade Thyristors are normally used.

For applications upto 400Hz, if Triacs are available to meet the voltage and current ratings of a particular application, Triacs are more commonly used.

Due to ac line commutation or natural commutation, there is no need of extra commutation circuitry or components and the circuits for ac voltage controllers are very simple.

Due to the nature of the output waveforms, the analysis, derivations of expressions for performance parameters are not simple, especially for the phase controlled ac voltage controllers with RL load. But however most of the practical loads are of the RL type and hence RL load should be considered in the analysis and design of ac voltage controller circuits.

6.2 Type of Ac Voltage Controllers

The ac voltage controllers are classified into two types based on the type of input ac supply applied to the circuit.

- Single Phase AC Controllers.
- Three Phase AC Controllers.

Single phase ac controllers operate with single phase ac supply voltage of 230V RMS at 50Hz in our country. Three phase ac controllers operate with 3 phase ac supply of 400V RMS at 50Hz supply frequency.

Each type of controller may be sub divided into

- Uni-directional or half wave ac controller.
- Bi-directional or full wave ac controller.

In brief different types of ac voltage controllers are

- Single phase half wave ac voltage controller (uni-directional controller).
- Single phase full wave ac voltage controller (bi-directional controller).
- Three phase half wave ac voltage controller (uni-directional controller).
- Three phase full wave ac voltage controller (bi-directional controller).

Applications of Ac Voltage Controllers

- Lighting / Illumination control in ac power circuits.
- Induction heating.
- Industrial heating & Domestic heating.
- Transformer tap changing (on load transformer tap changing).
- Speed control of induction motors (single phase and poly phase ac induction motor control).
- AC magnet controls.

6.3 Principle of On-Off Control Technique (Integral Cycle Control)

The basic principle of on-off control technique is explained with reference to a single phase full wave ac voltage controller circuit shown below. The thyristor switches T_1 and T_2 are turned on by applying appropriate gate trigger pulses to connect the input ac supply to the load for 'n' number of input cycles during the time interval t_{ON} . The thyristor switches T_1 and T_2 are turned off by blocking the gate trigger pulses for 'm' number of input cycles during the time interval t_{OFF} . The ac controller ON time t_{ON} usually consists of an integral number of input cycles.

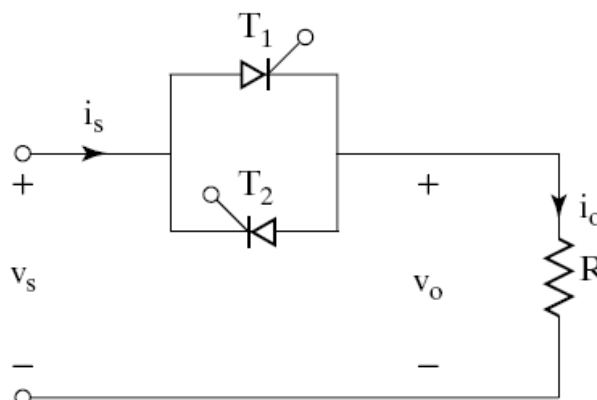

Fig 6.1: Single phase full wave AC voltage controller

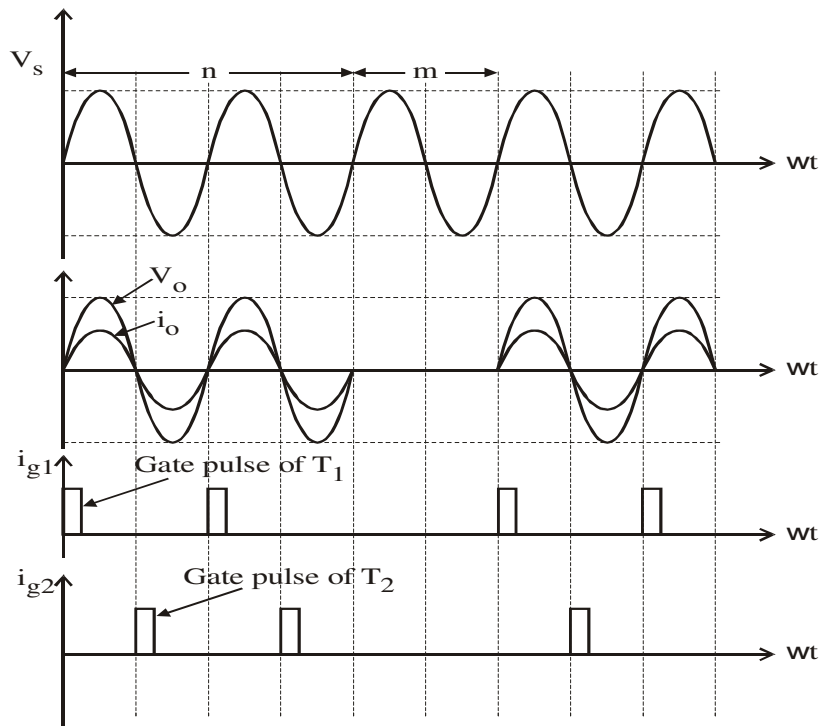

Fig 6.2: Waveforms

$R = R_L = \text{Load Resistance}$

Example

Referring to the waveforms of ON-OFF control technique in the above diagram,

$n =$ Two input cycles. Thyristors are turned ON during t_{ON} for two input cycles.

$m =$ One input cycle. Thyristors are turned OFF during t_{OFF} for one input cycle

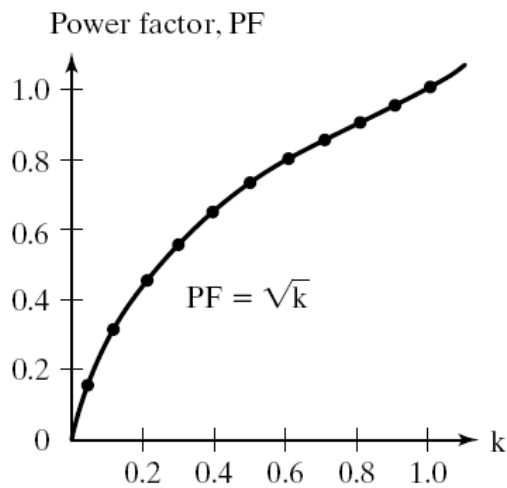

Fig 6.3: Power Factor

Thyristors are turned ON precisely at the zero voltage crossings of the input supply. The thyristor T_1 is turned on at the beginning of each positive half cycle by applying the gate trigger pulses to T_1 as shown, during the ON time t_{ON} . The load current flows in the positive direction, which is the downward direction as shown in the circuit diagram when T_1 conducts.

The thyristor T_2 is turned on at the beginning of each negative half cycle, by applying gating signal to the gate of T_2 , during t_{ON} . The load current flows in the reverse direction, which is the upward direction when T_2 conducts. Thus we obtain a bi-directional load current flow (alternating load current flow) in a ac voltage controller circuit, by triggering the thyristors alternately.

This type of control is used in applications which have high mechanical inertia and high thermal time constant (Industrial heating and speed control of ac motors). Due to zero voltage and zero current switching of Thyristors, the harmonics generated by switching actions are reduced.

For a sine wave input supply voltage,

$$v_s = V_m \sin \omega t = \sqrt{2}V_s \sin \omega t$$

$$V_s = \text{RMS value of input ac supply} = \frac{V_m}{\sqrt{2}} = \text{RMS phase supply voltage.}$$

If the input ac supply is connected to load for 'n' number of input cycles and disconnected for 'm' number of input cycles, then

$$t_{ON} = n \times T, \quad t_{OFF} = m \times T$$

Where $T = \frac{1}{f}$ = input cycle time (time period) and

f = input supply frequency.

t_{ON} = controller on time = $n \times T$.

t_{OFF} = controller off time = $m \times T$.

T_o = Output time period = $(t_{ON} + t_{OFF}) = (nT + mT)$.

We can show that,

$$\text{Output RMS voltage } V_{O(RMS)} = V_{i(RMS)} \sqrt{\frac{t_{ON}}{T_o}} = V_s \sqrt{\frac{t_{ON}}{T_o}}$$

Where $V_{i(RMS)}$ is the RMS input supply voltage = V_s .

(i) To derive an expression for the rms value of output voltage, for on-off control method.

$$\text{Output RMS voltage } V_{O(RMS)} = \sqrt{\frac{1}{\omega T_o} \int_{\omega t=0}^{\omega t_{ON}} V_m^2 \sin^2 \omega t \cdot d(\omega t)}$$

$$V_{O(RMS)} = \sqrt{\frac{V_m^2}{\omega T_o} \int_0^{\omega t_{ON}} \sin^2 \omega t \cdot d(\omega t)}$$

$$\text{Substituting for } \sin^2 \theta = \frac{1 - \cos 2\theta}{2}$$

$$V_{O(RMS)} = \sqrt{\frac{V_m^2}{\omega T_o} \int_0^{\omega t_{ON}} \left[\frac{1 - \cos 2\omega t}{2} \right] d(\omega t)}$$

$$V_{O(RMS)} = \sqrt{\frac{V_m^2}{2\omega T_o} \left[\int_0^{\omega t_{ON}} d(\omega t) - \int_0^{\omega t_{ON}} \cos 2\omega t \cdot d(\omega t) \right]}$$

$$V_{O(RMS)} = \sqrt{\frac{V_m^2}{2\omega T_o} \left[\frac{(\omega t)}{0} \Big|_0^{\omega t_{ON}} - \frac{\sin 2\omega t}{2} \Big|_0^{\omega t_{ON}} \right]}$$

$$V_{O(RMS)} = \sqrt{\frac{V_m^2}{2\omega T_o} \left[(\omega t_{ON} - 0) - \frac{\sin 2\omega t_{ON} - \sin 0}{2} \right]}$$

Now t_{ON} = an integral number of input cycles; Hence

$$t_{ON} = T, 2T, 3T, 4T, 5T, \dots \text{ \& } \omega t_{ON} = 2\pi, 4\pi, 6\pi, 8\pi, 10\pi, \dots$$

Where T is the input supply time period (T = input cycle time period). Thus we note that $\sin 2\omega t_{ON} = 0$

$$V_{O(RMS)} = \sqrt{\frac{V_m^2 \omega t_{ON}}{2\omega T_o}} = \frac{V_m}{\sqrt{2}} \sqrt{\frac{t_{ON}}{T_o}}$$

$$V_{O(RMS)} = V_{i(RMS)} \sqrt{\frac{t_{ON}}{T_o}} = V_s \sqrt{\frac{t_{ON}}{T_o}}$$

Where $V_{i(RMS)} = \frac{V_m}{\sqrt{2}} = V_s =$ RMS value of input supply voltage;

$$\frac{t_{ON}}{T_o} = \frac{t_{ON}}{t_{ON} + t_{OFF}} = \frac{nT}{nT + mT} = \frac{n}{(n+m)} = k = \text{duty cycle (d).}$$

$$V_{O(RMS)} = V_s \sqrt{\frac{n}{(n+m)}} = V_s \sqrt{k}$$

Performance Parameters of Ac Voltage Controllers

- **RMS Output (Load) Voltage**

$$V_{O(RMS)} = \left[\frac{n}{2\pi(n+m)} \int_0^{2\pi} V_m^2 \sin^2 \omega t \cdot d(\omega t) \right]^{1/2}$$

$$V_{O(RMS)} = \frac{V_m}{\sqrt{2}} \sqrt{\frac{n}{(m+n)}} = V_{i(RMS)} \sqrt{k} = V_S \sqrt{k}$$

$$V_{O(RMS)} = V_{i(RMS)} \sqrt{k} = V_S \sqrt{k}$$

Where $V_S = V_{i(RMS)}$ = RMS value of input supply voltage.

- **Duty Cycle**

$$k = \frac{t_{ON}}{T_O} = \frac{t_{ON}}{(t_{ON} + t_{OFF})} = \frac{nT}{(m+n)T}$$

Where, $k = \frac{n}{(m+n)}$ = duty cycle (d).

- **RMS Load Current**

$$I_{O(RMS)} = \frac{V_{O(RMS)}}{Z} = \frac{V_{O(RMS)}}{R_L}; \quad \text{For a resistive load } Z = R_L.$$

- **Output AC (Load) Power**

$$P_O = I_{O(RMS)}^2 \times R_L$$

- **Input Power Factor**

$$PF = \frac{P_O}{VA} = \frac{\text{output load power}}{\text{input supply volt amperes}} = \frac{P_O}{V_S I_S}$$

$$PF = \frac{I_{O(RMS)}^2 \times R_L}{V_{i(RMS)} \times I_{in(RMS)}}; \quad I_S = I_{in(RMS)} = \text{RMS input supply current.}$$

The input supply current is same as the load current $I_{in} = I_O = I_L$

Hence, RMS supply current = RMS load current; $I_{in(RMS)} = I_{O(RMS)}$.

$$PF = \frac{I_{O(RMS)}^2 \times R_L}{V_{i(RMS)} \times I_{in(RMS)}} = \frac{V_{O(RMS)}}{V_{i(RMS)}} = \frac{V_{i(RMS)} \sqrt{k}}{V_{i(RMS)}} = \sqrt{k}$$

$$PF = \sqrt{k} = \sqrt{\frac{n}{m+n}}$$

- **The Average Current of Thyristor $I_{T(Avg)}$**

Waveform of Thyristor Current

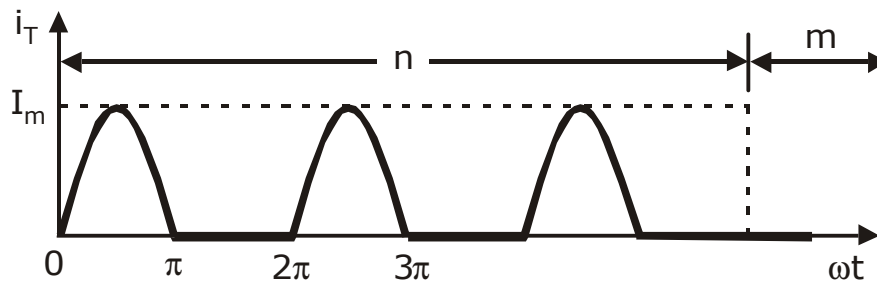

$$I_{T(Avg)} = \frac{n}{2\pi(m+n)} \int_0^{\pi} I_m \sin \omega t \cdot d(\omega t)$$

$$I_{T(Avg)} = \frac{nI_m}{2\pi(m+n)} \int_0^{\pi} \sin \omega t \cdot d(\omega t)$$

$$I_{T(Avg)} = \frac{nI_m}{2\pi(m+n)} \left[-\cos \omega t \Big|_0^{\pi} \right]$$

$$I_{T(Avg)} = \frac{nI_m}{2\pi(m+n)} [-\cos \pi + \cos 0]$$

$$I_{T(Avg)} = \frac{nI_m}{2\pi(m+n)} [-(-1) + 1]$$

$$I_{T(Avg)} = \frac{n}{2\pi(m+n)} [2I_m]$$

$$I_{T(Avg)} = \frac{I_m n}{\pi(m+n)} = \frac{k \cdot I_m}{\pi}$$

$$k = \text{duty cycle} = \frac{t_{ON}}{(t_{ON} + t_{OFF})} = \frac{n}{(n+m)}$$

$$I_{T(Avg)} = \frac{I_m n}{\pi(m+n)} = \frac{k \cdot I_m}{\pi},$$

Where $I_m = \frac{V_m}{R_L}$ = maximum or peak thyristor current.

• **RMS Current of Thyristor** $I_{T(RMS)}$

$$I_{T(RMS)} = \left[\frac{n}{2\pi(n+m)} \int_0^\pi I_m^2 \sin^2 \omega t \cdot d(\omega t) \right]^{1/2}$$

$$I_{T(RMS)} = \left[\frac{nI_m^2}{2\pi(n+m)} \int_0^\pi \sin^2 \omega t \cdot d(\omega t) \right]^{1/2}$$

$$I_{T(RMS)} = \left[\frac{nI_m^2}{2\pi(n+m)} \int_0^\pi \frac{(1 - \cos 2\omega t)}{2} d(\omega t) \right]^{1/2}$$

$$I_{T(RMS)} = \left[\frac{nI_m^2}{4\pi(n+m)} \left\{ \int_0^\pi d(\omega t) - \int_0^\pi \cos 2\omega t \cdot d(\omega t) \right\} \right]^{1/2}$$

$$I_{T(RMS)} = \left[\frac{nI_m^2}{4\pi(n+m)} \left\{ (\omega t) \Big|_0^\pi - \left(\frac{\sin 2\omega t}{2} \right) \Big|_0^\pi \right\} \right]^{1/2}$$

$$I_{T(RMS)} = \left[\frac{nI_m^2}{4\pi(n+m)} \left\{ (\pi - 0) - \left(\frac{\sin 2\pi - \sin 0}{2} \right) \right\} \right]^{1/2}$$

$$I_{T(RMS)} = \left[\frac{nI_m^2}{4\pi(n+m)} \{ \pi - 0 - 0 \} \right]^{1/2}$$

$$I_{T(RMS)} = \left[\frac{nI_m^2 \pi}{4\pi(n+m)} \right]^{1/2} = \left[\frac{nI_m^2}{4(n+m)} \right]^{1/2}$$

$$I_{T(RMS)} = \frac{I_m}{2} \sqrt{\frac{n}{(m+n)}} = \frac{I_m}{2} \sqrt{k}$$

$$I_{T(RMS)} = \frac{I_m}{2} \sqrt{k}$$

Problem

1. A single phase full wave ac voltage controller working on ON-OFF control technique has supply voltage of 230V, RMS 50Hz, load = 50Ω. The controller is ON for 30 cycles and off for 40 cycles. Calculate
- ON & OFF time intervals.
 - RMS output voltage.
 - Input P.F.
 - Average and RMS thyristor currents.

$$V_{in(RMS)} = 230V, \quad V_m = \sqrt{2} \times 230V = 325.269V, \quad V_m = 325.269V,$$

$$T = \frac{1}{f} = \frac{1}{50Hz} = 0.02 \text{ sec}, \quad T = 20ms.$$

n = number of input cycles during which controller is ON; $n = 30$.

m = number of input cycles during which controller is OFF; $m = 40$.

$$t_{ON} = n \times T = 30 \times 20ms = 600ms = 0.6 \text{ sec}$$

$$t_{ON} = n \times T = 0.6 \text{ sec} = \text{controller ON time.}$$

$$t_{OFF} = m \times T = 40 \times 20ms = 800ms = 0.8 \text{ sec}$$

$$t_{OFF} = m \times T = 0.8 \text{ sec} = \text{controller OFF time.}$$

$$\text{Duty cycle } k = \frac{n}{(m+n)} = \frac{30}{(40+30)} = 0.4285$$

RMS output voltage

$$V_{O(RMS)} = V_{i(RMS)} \times \sqrt{\frac{n}{(m+n)}}$$

$$V_{O(RMS)} = 230V \times \sqrt{\frac{30}{(30+40)}} = 230\sqrt{\frac{3}{7}}$$

$$V_{O(RMS)} = 230V \sqrt{0.42857} = 230 \times 0.65465$$

$$V_{O(RMS)} = 150.570V$$

$$I_{O(RMS)} = \frac{V_{O(RMS)}}{Z} = \frac{V_{O(RMS)}}{R_L} = \frac{150.570V}{50\Omega} = 3.0114A$$

$$P_o = I_{O(RMS)}^2 \times R_L = 3.0114^2 \times 50 = 453.426498W$$

Input Power Factor $P.F = \sqrt{k}$

$$PF = \sqrt{\frac{n}{(m+n)}} = \sqrt{\frac{30}{70}} = \sqrt{0.4285}$$

$$PF = 0.654653$$

Average Thyristor Current Rating

$$I_{T(Avg)} = \frac{I_m}{\pi} \times \left(\frac{n}{m+n} \right) = \frac{k \times I_m}{\pi}$$

where
$$I_m = \frac{V_m}{R_L} = \frac{\sqrt{2} \times 230}{50} = \frac{325.269}{50}$$

$$I_m = 6.505382A = \text{Peak (maximum) thyristor current.}$$

$$I_{T(Avg)} = \frac{6.505382}{\pi} \times \left(\frac{3}{7} \right)$$

$$I_{T(Avg)} = 0.88745A$$

RMS Current Rating of Thyristor

$$I_{T(RMS)} = \frac{I_m}{2} \sqrt{\frac{n}{(m+n)}} = \frac{I_m}{2} \sqrt{k} = \frac{6.505382}{2} \times \sqrt{\frac{3}{7}}$$

$$I_{T(RMS)} = 2.129386A$$

6.4 Principle of AC Phase Control

The basic principle of ac phase control technique is explained with reference to a single phase half wave ac voltage controller (unidirectional controller) circuit shown in the below figure.

The half wave ac controller uses one thyristor and one diode connected in parallel across each other in opposite direction that is anode of thyristor T_1 is connected to the cathode of diode D_1 and the cathode of T_1 is connected to the anode of D_1 . The output voltage across the load resistor 'R' and hence the ac power flow to the load is controlled by varying the trigger angle ' α '.

The trigger angle or the delay angle ' α ' refers to the value of ωt or the instant at which the thyristor T_1 is triggered to turn it ON, by applying a suitable gate trigger pulse between the gate and cathode lead.

The thyristor T_1 is forward biased during the positive half cycle of input ac supply. It can be triggered and made to conduct by applying a suitable gate trigger pulse only during the

positive half cycle of input supply. When T_1 is triggered it conducts and the load current flows through the thyristor T_1 , the load and through the transformer secondary winding.

By assuming T_1 as an ideal thyristor switch it can be considered as a closed switch when it is ON during the period $\omega t = \alpha$ to π radians. The output voltage across the load follows the input supply voltage when the thyristor T_1 is turned-on and when it conducts from $\omega t = \alpha$ to π radians. When the input supply voltage decreases to zero at $\omega t = \pi$, for a resistive load the load current also falls to zero at $\omega t = \pi$ and hence the thyristor T_1 turns off at $\omega t = \pi$. Between the time period $\omega t = \pi$ to 2π , when the supply voltage reverses and becomes negative the diode D_1 becomes forward biased and hence turns ON and conducts. The load current flows in the opposite direction during $\omega t = \pi$ to 2π radians when D_1 is ON and the output voltage follows the negative half cycle of input supply.

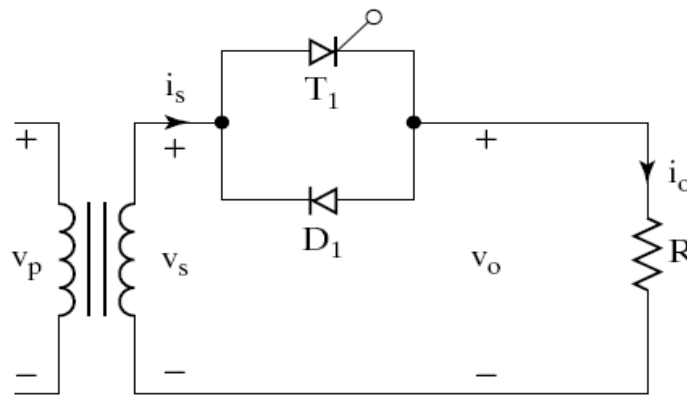
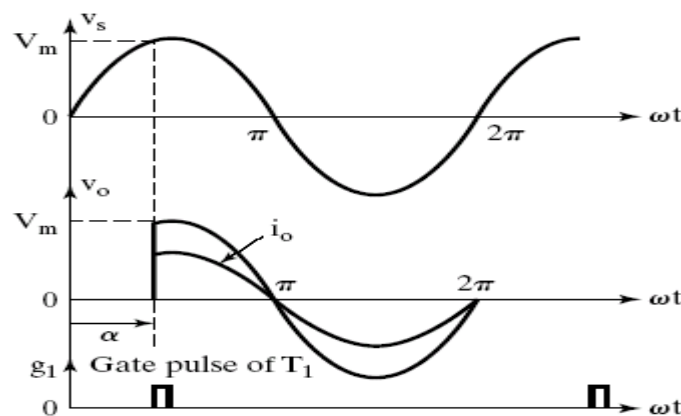

Fig 6.4: Halfwave AC phase controller (Unidirectional Controller)



Equations Input AC Supply Voltage across the Transformer Secondary Winding.

$$v_s = V_m \sin \omega t$$

$$V_s = V_{in(RMS)} = \frac{V_m}{\sqrt{2}} = \text{RMS value of secondary supply voltage.}$$

Output Load Voltage

$$v_o = v_L = 0; \text{ for } \omega t = 0 \text{ to } \alpha$$

$$v_o = v_L = V_m \sin \omega t; \text{ for } \omega t = \alpha \text{ to } 2\pi.$$

Output Load Current

$$i_o = i_L = \frac{v_o}{R_L} = \frac{V_m \sin \omega t}{R_L}; \text{ for } \omega t = \alpha \text{ to } 2\pi.$$

$$i_o = i_L = 0; \text{ for } \omega t = 0 \text{ to } \alpha.$$

(i) To Derive an Expression for rms Output Voltage $V_{O(RMS)}$.

$$V_{O(RMS)} = \sqrt{\frac{1}{2\pi} \left[\int_{\alpha}^{2\pi} V_m^2 \sin^2 \omega t . d(\omega t) \right]}$$

$$V_{O(RMS)} = \sqrt{\frac{V_m^2}{2\pi} \left[\int_{\alpha}^{2\pi} \left(\frac{1 - \cos 2\omega t}{2} \right) . d(\omega t) \right]}$$

$$V_{O(RMS)} = \sqrt{\frac{V_m^2}{4\pi} \left[\int_{\alpha}^{2\pi} (1 - \cos 2\omega t) . d(\omega t) \right]}$$

$$V_{O(RMS)} = \frac{V_m}{2\sqrt{\pi}} \sqrt{\left[\int_{\alpha}^{2\pi} d(\omega t) - \int_{\alpha}^{2\pi} \cos 2\omega t . d\omega t \right]}$$

$$V_{O(RMS)} = \frac{V_m}{2\sqrt{\pi}} \sqrt{\left[\left(\omega t \right) \Big|_{\alpha}^{2\pi} - \left(\frac{\sin 2\omega t}{2} \right) \Big|_{\alpha}^{2\pi} \right]}$$

$$V_{O(RMS)} = \frac{V_m}{2\sqrt{\pi}} \sqrt{\left(2\pi - \alpha \right) - \left(\frac{\sin 2\omega t}{2} \right) \Big|_{\alpha}^{2\pi}}$$

$$V_{O(RMS)} = \frac{V_m}{2\sqrt{\pi}} \sqrt{\left(2\pi - \alpha \right) - \left\{ \frac{\sin 4\pi}{2} - \frac{\sin 2\alpha}{2} \right\}} \quad ; \sin 4\pi = 0$$

$$V_{O(RMS)} = \frac{V_m}{2\sqrt{\pi}} \sqrt{(2\pi - \alpha) + \frac{\sin 2\alpha}{2}}$$

$$V_{O(RMS)} = \frac{V_m}{\sqrt{2}\sqrt{2\pi}} \sqrt{(2\pi - \alpha) + \frac{\sin 2\alpha}{2}}$$

$$V_{O(RMS)} = \frac{V_m}{\sqrt{2}} \sqrt{\frac{1}{2\pi} \left[(2\pi - \alpha) + \frac{\sin 2\alpha}{2} \right]}$$

$$V_{O(RMS)} = V_{i(RMS)} \sqrt{\frac{1}{2\pi} \left[(2\pi - \alpha) + \frac{\sin 2\alpha}{2} \right]}$$

$$V_{O(RMS)} = V_s \sqrt{\frac{1}{2\pi} \left[(2\pi - \alpha) + \frac{\sin 2\alpha}{2} \right]}$$

Where, $V_{i(RMS)} = V_s = \frac{V_m}{\sqrt{2}}$ = RMS value of input supply voltage (across the transformer secondary winding).

Note: Output RMS voltage across the load is controlled by changing ' α ' as indicated by the expression for $V_{O(RMS)}$

PLOT OF $V_{O(RMS)}$ VERSUS TRIGGER ANGLE α FOR A SINGLE PHASE HALF-WAVE AC VOLTAGE CONTROLLER (UNIDIRECTIONAL CONTROLLER)

$$V_{O(RMS)} = \frac{V_m}{\sqrt{2}} \sqrt{\frac{1}{2\pi} \left[(2\pi - \alpha) + \frac{\sin 2\alpha}{2} \right]}$$

$$V_{O(RMS)} = V_s \sqrt{\frac{1}{2\pi} \left[(2\pi - \alpha) + \frac{\sin 2\alpha}{2} \right]}$$

By using the expression for $V_{O(RMS)}$ we can obtain the control characteristics, which is the plot of RMS output voltage $V_{O(RMS)}$ versus the trigger angle α . A typical control characteristic of single phase half-wave phase controlled ac voltage controller is as shown below

Trigger angle α in degrees	Trigger angle α in radians	$V_{O(RMS)}$
0	0	$V_s = \frac{V_m}{\sqrt{2}}$

30°	$\frac{\pi}{6} ; \left(\frac{1\pi}{6}\right)$	$0.992765 V_s$
60°	$\frac{\pi}{3} ; \left(\frac{2\pi}{6}\right)$	$0.949868 V_s$
90°	$\frac{\pi}{2} ; \left(\frac{3\pi}{6}\right)$	$0.866025 V_s$
120°	$\frac{2\pi}{3} ; \left(\frac{4\pi}{6}\right)$	$0.77314 V_s$
150°	$\frac{5\pi}{6} ; \left(\frac{5\pi}{6}\right)$	$0.717228 V_s$
180°	$\pi ; \left(\frac{6\pi}{6}\right)$	$0.707106 V_s$

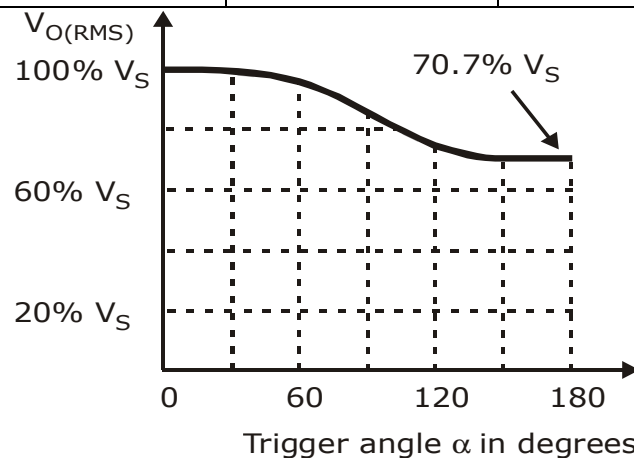

Fig 6.5: Control characteristics of single phase half-wave phase controlled ac voltage controller

Note: We can observe from the control characteristics and the table given above that the range of RMS output voltage control is from 100% of V_s to 70.7% of V_s when we vary the trigger angle α from zero to 180 degrees. Thus the half wave ac controller has the drawback of limited range RMS output voltage control.

(ii) To Calculate the Average Value (Dc Value) Of Output Voltage

$$V_{O(dc)} = \frac{1}{2\pi} \int_{\alpha}^{2\pi} V_m \sin \omega t . d(\omega t)$$

$$V_{O(dc)} = \frac{V_m}{2\pi} \int_{\alpha}^{2\pi} \sin \omega t . d(\omega t)$$

$$V_{O(dc)} = \frac{V_m}{2\pi} \left[-\cos \omega t / \alpha \right]$$

$$V_{O(dc)} = \frac{V_m}{2\pi} [-\cos 2\pi + \cos \alpha] \quad ; \quad \cos 2\pi = 1$$

$$V_{dc} = \frac{V_m}{2\pi} [\cos \alpha - 1] \quad ; \quad V_m = \sqrt{2}V_s$$

$$\text{Hence } V_{dc} = \frac{\sqrt{2}V_s}{2\pi}(\cos \alpha - 1)$$

When ' α ' is varied from 0 to π . V_{dc} varies from 0 to $-\frac{V_m}{\pi}$

Disadvantages of single phase half wave ac voltage controller.

- The output load voltage has a DC component because the two halves of the output voltage waveform are not symmetrical with respect to '0' level. The input supply current waveform also has a DC component (average value) which can result in the problem of core saturation of the input supply transformer.
- The half wave ac voltage controller using a single thyristor and a single diode provides control on the thyristor only in one half cycle of the input supply. Hence ac power flow to the load can be controlled only in one half cycle.
- Half wave ac voltage controller gives limited range of RMS output voltage control. Because the RMS value of ac output voltage can be varied from a maximum of 100% of V_s at a trigger angle $\alpha = 0$ to a low of 70.7% of V_s at $\alpha = \pi$ Radians.

These drawbacks of single phase half wave ac voltage controller can be over come by using a single phase full wave ac voltage controller.

Applications of rms Voltage Controller

- Speed control of induction motor (polyphase ac induction motor).
- Heater control circuits (industrial heating).
- Welding power control.
- Induction heating.
- On load transformer tap changing.
- Lighting control in ac circuits.
- Ac magnet controls.

Problem

1. A single phase half-wave ac voltage controller has a load resistance $R = 50\Omega$; input ac supply voltage is 230V RMS at 50Hz. The input supply transformer has a turn's ratio of 1:1. If the thyristor T_1 is triggered at $\alpha = 60^\circ$. Calculate
 - RMS output voltage.
 - Output power.
 - RMS load current and average load current.
 - Input power factor.
 - Average and RMS thyristor current.

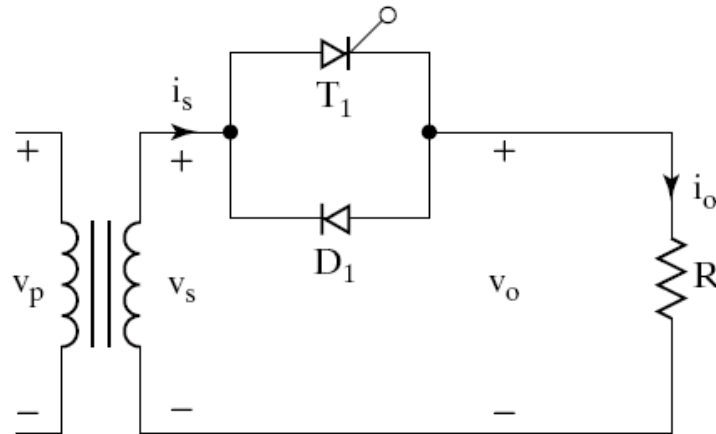

Given,

$V_p = 230V$, RMS primary supply voltage.

$f =$ Input supply frequency = 50Hz.

$R_L = 50\Omega$

$\alpha = 60^\circ = \frac{\pi}{3}$ radians.

$V_s =$ RMS secondary voltage.

$$\frac{V_p}{V_s} = \frac{N_p}{N_s} = \frac{1}{1} = 1$$

Therefore $V_p = V_s = 230V$

Where, $N_p =$ Number of turns in the primary winding.

$N_s =$ Number of turns in the secondary winding.

- **RMS Value of Output (Load) Voltage $V_{O(RMS)}$**

$$V_{O(RMS)} = \sqrt{\frac{1}{2\pi} \int_{\alpha}^{2\pi} V_m^2 \sin^2 \omega t \cdot d(\omega t)}$$

We have obtained the expression for $V_{O(RMS)}$ as

$$V_{O(RMS)} = V_s \sqrt{\frac{1}{2\pi} [(2\pi - \alpha)] + \frac{\sin 2\alpha}{2}}$$

$$V_{O(RMS)} = 230 \sqrt{\frac{1}{2\pi} \left[\left(2\pi - \frac{\pi}{3} \right) + \frac{\sin 120^\circ}{2} \right]}$$

$$V_{O(RMS)} = 230 \sqrt{\frac{1}{2\pi} [5.669]} = 230 \times 0.94986$$

$$V_{O(RMS)} = 218.4696 \text{ V} \approx 218.47 \text{ V}$$

- **RMS Load Current** $I_{O(RMS)}$

$$I_{O(RMS)} = \frac{V_{O(RMS)}}{R_L} = \frac{218.46966}{50} = 4.36939 \text{ Amps}$$

- **Output Load Power** P_o

$$P_o = I_{O(RMS)}^2 \times R_L = (4.36939)^2 \times 50 = 954.5799 \text{ Watts}$$

$$P_o = 0.9545799 \text{ KW}$$

- **Input Power Factor**

$$PF = \frac{P_o}{V_s \times I_s}$$

V_s = RMS secondary supply voltage = 230V.

I_s = RMS secondary supply current = RMS load current.

$$\therefore I_s = I_{O(RMS)} = 4.36939 \text{ Amps}$$

$$\therefore PF = \frac{954.5799 \text{ W}}{(230 \times 4.36939) \text{ W}} = 0.9498$$

- **Average Output (Load) Voltage**

$$V_{O(dc)} = \frac{1}{2\pi} \left[\int_{\alpha}^{2\pi} V_m \sin \omega t \cdot d(\omega t) \right]$$

We have obtained the expression for the average / DC output voltage as,

$$V_{O(dc)} = \frac{V_m}{2\pi} [\cos \alpha - 1]$$

$$V_{O(dc)} = \frac{\sqrt{2} \times 230}{2\pi} [\cos(60^\circ) - 1] = \frac{325.2691193}{2\pi} [0.5 - 1]$$

$$V_{O(dc)} = \frac{325.2691193}{2\pi} [-0.5] = -25.88409 \text{ Volts}$$

- **Average DC Load Current**

$$I_{O(dc)} = \frac{V_{O(dc)}}{R_L} = \frac{-25.884094}{50} = -0.51768 \text{ Amps}$$

- **Average & RMS Thyristor Currents**

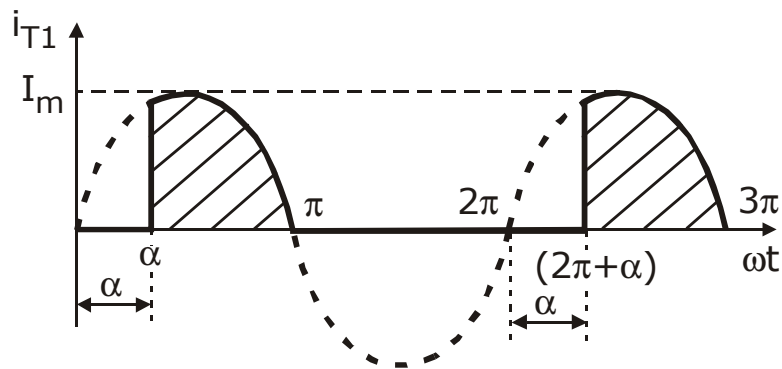

Fig 6.6: Thyristor Current Waveform

Referring to the thyristor current waveform of a single phase half-wave ac voltage controller circuit, we can calculate the average thyristor current $I_{T(Avg)}$ as

$$I_{T(Avg)} = \frac{1}{2\pi} \left[\int_{\alpha}^{\pi} I_m \sin \omega t \cdot d(\omega t) \right]$$

$$I_{T(Avg)} = \frac{I_m}{2\pi} \left[\int_{\alpha}^{\pi} \sin \omega t \cdot d(\omega t) \right]$$

$$I_{T(Avg)} = \frac{I_m}{2\pi} \left[(-\cos \omega t) \Big|_{\alpha}^{\pi} \right]$$

$$I_{T(Avg)} = \frac{I_m}{2\pi} [-\cos(\pi) + \cos \alpha]$$

$$I_{T(Avg)} = \frac{I_m}{2\pi} [1 + \cos \alpha]$$

Where, $I_m = \frac{V_m}{R_L}$ = Peak thyristor current = Peak load current.

$$I_m = \frac{\sqrt{2} \times 230}{50}$$

$$I_m = 6.505382 \text{ Amps}$$

$$I_{T(Avg)} = \frac{V_m}{2\pi R_L} [1 + \cos \alpha]$$

$$I_{T(Avg)} = \frac{\sqrt{2} \times 230}{2\pi \times 50} [1 + \cos(60^\circ)]$$

$$I_{T(Avg)} = \frac{\sqrt{2} \times 230}{100\pi} [1 + 0.5]$$

$$I_{T(Avg)} = 1.5530 \text{ Amps}$$

- RMS thyristor current $I_{T(RMS)}$ can be calculated by using the expression

$$I_{T(RMS)} = \sqrt{\frac{1}{2\pi} \left[\int_{\alpha}^{\pi} I_m^2 \sin^2 \omega t . d(\omega t) \right]}$$

$$I_{T(RMS)} = \sqrt{\frac{I_m^2}{2\pi} \left[\int_{\alpha}^{\pi} \frac{(1 - \cos 2\omega t)}{2} . d(\omega t) \right]}$$

$$I_{T(RMS)} = \sqrt{\frac{I_m^2}{4\pi} \left[\int_{\alpha}^{\pi} d(\omega t) - \int_{\alpha}^{\pi} \cos 2\omega t . d(\omega t) \right]}$$

$$I_{T(RMS)} = I_m \sqrt{\frac{1}{4\pi} \left[(\omega t) \Big|_{\alpha}^{\pi} - \left(\frac{\sin 2\omega t}{2} \right) \Big|_{\alpha}^{\pi} \right]}$$

$$I_{T(RMS)} = I_m \sqrt{\frac{1}{4\pi} \left[(\pi - \alpha) - \left\{ \frac{\sin 2\pi - \sin 2\alpha}{2} \right\} \right]}$$

$$I_{T(RMS)} = I_m \sqrt{\frac{1}{4\pi} \left[(\pi - \alpha) + \frac{\sin 2\alpha}{2} \right]}$$

$$I_{T(RMS)} = \frac{I_m}{\sqrt{2}} \sqrt{\frac{1}{2\pi} \left[(\pi - \alpha) + \frac{\sin 2\alpha}{2} \right]}$$

$$I_{T(RMS)} = \frac{6.50538}{\sqrt{2}} \sqrt{\frac{1}{2\pi} \left[\left(\pi - \frac{\pi}{3} \right) + \frac{\sin(120^\circ)}{2} \right]}$$

$$I_{T(RMS)} = 4.6 \sqrt{\frac{1}{2\pi} \left[\left(\frac{2\pi}{3} \right) + \frac{0.8660254}{2} \right]}$$

$$I_{T(RMS)} = 4.6 \times 0.6342 = 2.91746A$$

$$I_{T(RMS)} = 2.91746 \text{ Amps}$$

6.5 Single Phase Full Wave Ac Voltage Controller (Ac Regulator) or Rms Voltage Controller with Resistive Load

Single phase full wave ac voltage controller circuit using two SCRs or a single triac is generally used in most of the ac control applications. The ac power flow to the load can be controlled in both the half cycles by varying the trigger angle ' α '.

The RMS value of load voltage can be varied by varying the trigger angle ' α '. The input supply current is alternating in the case of a full wave ac voltage controller and due to the symmetrical nature of the input supply current waveform there is no dc component of input supply current i.e., the average value of the input supply current is zero.

A single phase full wave ac voltage controller with a resistive load is shown in the figure below. It is possible to control the ac power flow to the load in both the half cycles by adjusting the trigger angle ' α '. Hence the full wave ac voltage controller is also referred to as to a bi-directional controller.

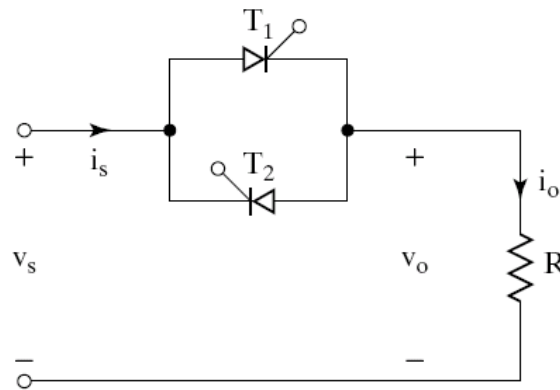

Fig 6.7: Single phase full wave ac voltage controller (Bi-directional Controller) using SCRs

The thyristor T_1 is forward biased during the positive half cycle of the input supply voltage. The thyristor T_1 is triggered at a delay angle of ' α ' ($0 \leq \alpha \leq \pi$ radians). Considering the ON thyristor T_1 as an ideal closed switch the input supply voltage appears across the load resistor R_L and the output voltage $v_o = v_s$ during $\omega t = \alpha$ to π radians. The load current flows through the ON thyristor T_1 and through the load resistor R_L in the downward direction during the conduction time of T_1 from $\omega t = \alpha$ to π radians.

At $\omega t = \pi$, when the input voltage falls to zero the thyristor current (which is flowing through the load resistor R_L) falls to zero and hence T_1 naturally turns off. No current flows in the circuit during $\omega t = \pi$ to $(\pi + \alpha)$.

The thyristor T_2 is forward biased during the negative cycle of input supply and when thyristor T_2 is triggered at a delay angle $(\pi + \alpha)$, the output voltage follows the negative halfcycle of input from $\omega t = (\pi + \alpha)$ to 2π . When T_2 is ON, the load current flows in the reverse direction (upward direction) through T_2 during $\omega t = (\pi + \alpha)$ to 2π radians. The time interval (spacing) between the gate trigger pulses of T_1 and T_2 is kept at π radians or 180° . At $\omega t = 2\pi$ the input supply voltage falls to zero and hence the load current also falls to zero and thyristor T_2 turn off naturally.

Instead of using two SCR's in parallel, a Triac can be used for full wave ac voltage control.

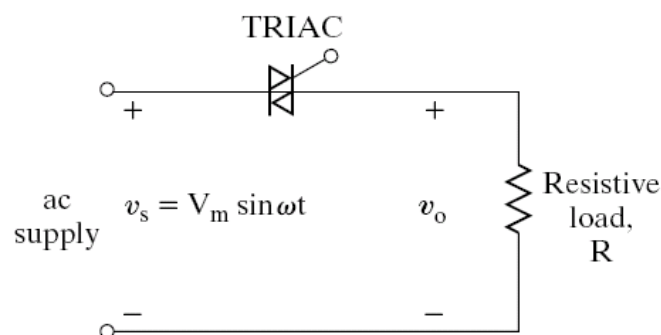

Fig 6.8: Single phase full wave ac voltage controller (Bi-directional Controller) using TRIAC

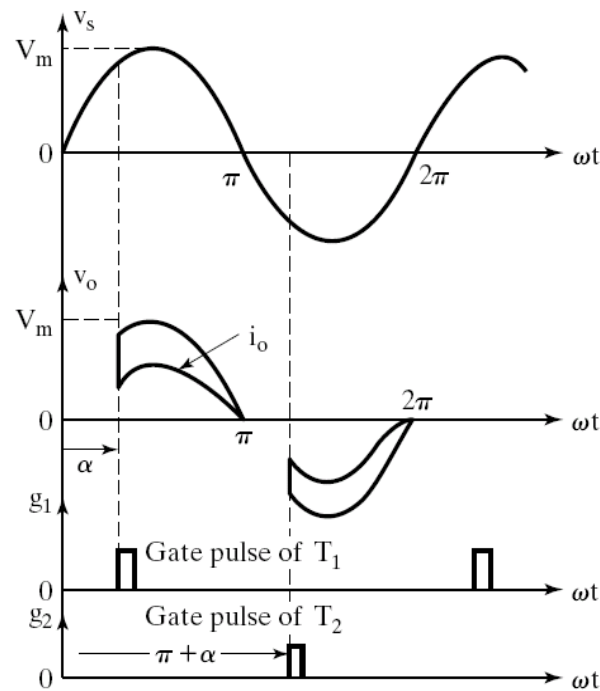

Fig 6.9: Waveforms of single phase full wave ac voltage controller

Equations

Input supply voltage

$$v_s = V_m \sin \omega t = \sqrt{2} V_S \sin \omega t ;$$

Output voltage across the load resistor R_L ;

$$v_o = v_L = V_m \sin \omega t ;$$

$$\text{for } \omega t = \alpha \text{ to } \pi \text{ and } \omega t = (\pi + \alpha) \text{ to } 2\pi$$

Output load current

$$i_o = \frac{v_o}{R_L} = \frac{V_m \sin \omega t}{R_L} = I_m \sin \omega t ;$$

$$\text{for } \omega t = \alpha \text{ to } \pi \text{ and } \omega t = (\pi + \alpha) \text{ to } 2\pi$$

(i) To Derive an Expression for the Rms Value of Output (Load) Voltage

The RMS value of output voltage (load voltage) can be found using the expression

$$V_{O(RMS)}^2 = V_{L(RMS)}^2 = \frac{1}{2\pi} \int_0^{2\pi} v_L^2 d(\omega t) ;$$

For a full wave ac voltage controller, we can see that the two half cycles of output voltage waveforms are symmetrical and the output pulse time period (or output pulse

repetition time) is π radians. Hence we can also calculate the RMS output voltage by using the expression given below.

$$V_{L(RMS)}^2 = \frac{1}{\pi} \int_0^{\pi} V_m^2 \sin^2 \omega t \cdot d\omega t$$

$$V_{L(RMS)}^2 = \frac{1}{2\pi} \int_0^{2\pi} v_L^2 \cdot d(\omega t) ;$$

$$v_L = v_O = V_m \sin \omega t ; \text{ For } \omega t = \alpha \text{ to } \pi \text{ and } \omega t = (\pi + \alpha) \text{ to } 2\pi$$

Hence,

$$\begin{aligned} V_{L(RMS)}^2 &= \frac{1}{2\pi} \left[\int_{\alpha}^{\pi} (V_m \sin \omega t)^2 d(\omega t) + \int_{\pi+\alpha}^{2\pi} (V_m \sin \omega t)^2 d(\omega t) \right] \\ &= \frac{1}{2\pi} \left[V_m^2 \int_{\alpha}^{\pi} \sin^2 \omega t \cdot d(\omega t) + V_m^2 \int_{\pi+\alpha}^{2\pi} \sin^2 \omega t \cdot d(\omega t) \right] \\ &= \frac{V_m^2}{2\pi} \left[\int_{\alpha}^{\pi} \frac{1 - \cos 2\omega t}{2} d(\omega t) + \int_{\pi+\alpha}^{2\pi} \frac{1 - \cos 2\omega t}{2} d(\omega t) \right] \\ &= \frac{V_m^2}{2\pi \times 2} \left[\int_{\alpha}^{\pi} d(\omega t) - \int_{\alpha}^{\pi} \cos 2\omega t \cdot d(\omega t) + \int_{\pi+\alpha}^{2\pi} d(\omega t) - \int_{\pi+\alpha}^{2\pi} \cos 2\omega t \cdot d(\omega t) \right] \\ &= \frac{V_m^2}{4\pi} \left[(\omega t) \Big|_{\alpha}^{\pi} + (\omega t) \Big|_{\pi+\alpha}^{2\pi} - \left[\frac{\sin 2\omega t}{2} \right]_{\alpha}^{\pi} - \left[\frac{\sin 2\omega t}{2} \right]_{\pi+\alpha}^{2\pi} \right] \\ &= \frac{V_m^2}{4\pi} \left[(\pi - \alpha) + (\pi - \alpha) - \frac{1}{2} (\sin 2\pi - \sin 2\alpha) - \frac{1}{2} (\sin 4\pi - \sin 2(\pi + \alpha)) \right] \\ &= \frac{V_m^2}{4\pi} \left[2(\pi - \alpha) - \frac{1}{2} (0 - \sin 2\alpha) - \frac{1}{2} (0 - \sin 2(\pi + \alpha)) \right] \\ &= \frac{V_m^2}{4\pi} \left[2(\pi - \alpha) + \frac{\sin 2\alpha}{2} + \frac{\sin 2(\pi + \alpha)}{2} \right] \\ &= \frac{V_m^2}{4\pi} \left[2(\pi - \alpha) + \frac{\sin 2\alpha}{2} + \frac{\sin(2\pi + 2\alpha)}{2} \right] \end{aligned}$$

$$= \frac{V_m^2}{4\pi} \left[2(\pi - \alpha) + \frac{\sin 2\alpha}{2} + \frac{1}{2} (\sin 2\pi \cdot \cos 2\alpha + \cos 2\pi \cdot \sin 2\alpha) \right]$$

$$\sin 2\pi = 0 \quad \& \quad \cos 2\pi = 1$$

Therefore,

$$V_{L(RMS)}^2 = \frac{V_m^2}{4\pi} \left[2(\pi - \alpha) + \frac{\sin 2\alpha}{2} + \frac{\sin 2\alpha}{2} \right]$$

$$= \frac{V_m^2}{4\pi} [2(\pi - \alpha) + \sin 2\alpha]$$

$$V_{L(RMS)}^2 = \frac{V_m^2}{4\pi} [(2\pi - 2\alpha) + \sin 2\alpha]$$

Taking the square root, we get

$$V_{L(RMS)} = \frac{V_m}{2\sqrt{\pi}} \sqrt{[(2\pi - 2\alpha) + \sin 2\alpha]}$$

$$V_{L(RMS)} = \frac{V_m}{\sqrt{2}\sqrt{2\pi}} \sqrt{[(2\pi - 2\alpha) + \sin 2\alpha]}$$

$$V_{L(RMS)} = \frac{V_m}{\sqrt{2}} \sqrt{\frac{1}{2\pi} [(2\pi - 2\alpha) + \sin 2\alpha]}$$

$$V_{L(RMS)} = \frac{V_m}{\sqrt{2}} \sqrt{\frac{1}{2\pi} \left[2 \left\{ (\pi - \alpha) + \frac{\sin 2\alpha}{2} \right\} \right]}$$

$$V_{L(RMS)} = \frac{V_m}{\sqrt{2}} \sqrt{\frac{1}{\pi} \left[(\pi - \alpha) + \frac{\sin 2\alpha}{2} \right]}$$

$$V_{L(RMS)} = V_{i(RMS)} \sqrt{\frac{1}{\pi} \left[(\pi - \alpha) + \frac{\sin 2\alpha}{2} \right]}$$

$$V_{L(RMS)} = V_s \sqrt{\frac{1}{\pi} \left[(\pi - \alpha) + \frac{\sin 2\alpha}{2} \right]}$$

Maximum RMS voltage will be applied to the load when $\alpha = 0$, in that case the full sine wave appears across the load. RMS load voltage will be the same as the RMS supply voltage $= \frac{V_m}{\sqrt{2}}$. When α is increased the RMS load voltage decreases.

$$V_{L(RMS)} \Big|_{\alpha=0} = \frac{V_m}{\sqrt{2}} \sqrt{\frac{1}{\pi} \left[(\pi - 0) + \frac{\sin 2 \times 0}{2} \right]}$$

$$V_{L(RMS)} \Big|_{\alpha=0} = \frac{V_m}{\sqrt{2}} \sqrt{\frac{1}{\pi} \left[(\pi) + \frac{0}{2} \right]}$$

$$V_{L(RMS)} \Big|_{\alpha=0} = \frac{V_m}{\sqrt{2}} = V_{i(RMS)} = V_s$$

The output control characteristic for a single phase full wave ac voltage controller with resistive load can be obtained by plotting the equation for $V_{O(RMS)}$

Control Characteristic of Single Phase Full-Wave Ac Voltage Controller with Resistive Load

The control characteristic is the plot of RMS output voltage $V_{O(RMS)}$ versus the trigger angle α ; which can be obtained by using the expression for the RMS output voltage of a full-wave ac controller with resistive load.

$$V_{O(RMS)} = V_s \sqrt{\frac{1}{\pi} \left[(\pi - \alpha) + \frac{\sin 2\alpha}{2} \right]} \quad ;$$

Where $V_s = \frac{V_m}{\sqrt{2}}$ = RMS value of input supply voltage

Trigger angle α in degrees	Trigger angle α in radians	$V_{O(RMS)}$	%
0	0	V_s	100% V_s
30°	$\frac{\pi}{6}$; $(\frac{1\pi}{6})$	0.985477 V_s	98.54% V_s
60°	$\frac{\pi}{3}$; $(\frac{2\pi}{6})$	0.896938 V_s	89.69% V_s
90°	$\frac{\pi}{2}$; $(\frac{3\pi}{6})$	0.7071 V_s	70.7% V_s
120°	$\frac{2\pi}{3}$; $(\frac{4\pi}{6})$	0.44215 V_s	44.21% V_s
150°	$\frac{5\pi}{6}$; $(\frac{5\pi}{6})$	0.1698 V_s	16.98% V_s

180°	π	$;(6\pi/6)$	$0 V_s$	$0 V_s$
-------------	-------	-------------	---------	---------

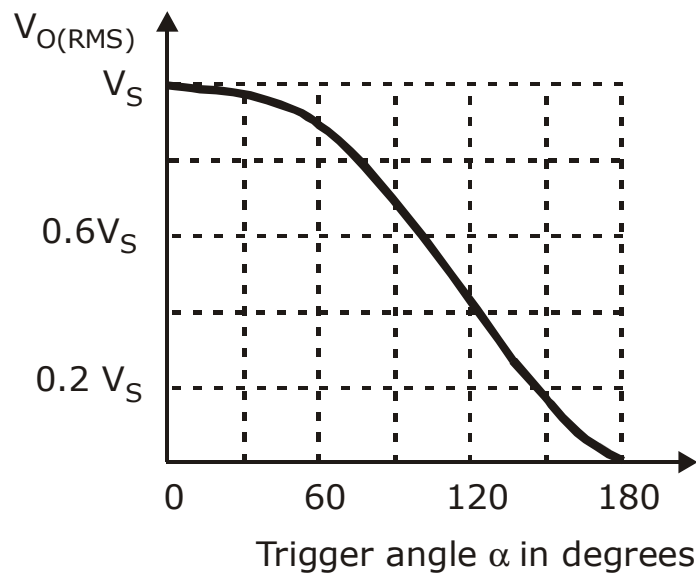

We can notice from the figure, that we obtain a much better output control characteristic by using a single phase full wave ac voltage controller. The RMS output voltage can be varied from a maximum of 100% V_s at $\alpha = 0$ to a minimum of '0' at $\alpha = 180^\circ$. Thus we get a full range output voltage control by using a single phase full wave ac voltage controller.

Need For Isolation

In the single phase full wave ac voltage controller circuit using two SCRs or Thyristors T_1 and T_2 in parallel, the gating circuits (gate trigger pulse generating circuits) of Thyristors T_1 and T_2 must be isolated. Figure shows a pulse transformer with two separate windings to provide isolation between the gating signals of T_1 and T_2 .

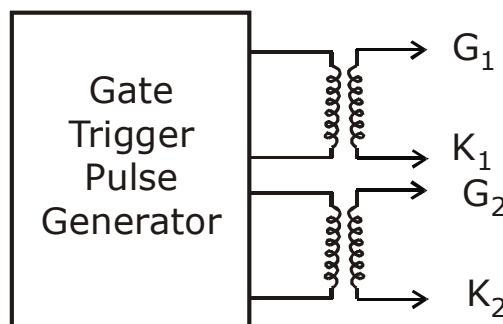

Fig 6.10: Pulse Transformer

6.6 Single Phase Full Wave Ac Voltage Controller (Bidirectional Controller) With RL Load

In this section we will discuss the operation and performance of a single phase full wave ac voltage controller with RL load. In practice most of the loads are of RL type. For example if we consider a single phase full wave ac voltage controller controlling the speed of a single phase ac induction motor, the load which is the induction motor winding is an RL type of load, where R represents the motor winding resistance and L represents the motor winding inductance.

A single phase full wave ac voltage controller circuit (bidirectional controller) with an RL load using two thyristors T_1 and T_2 (T_1 and T_2 are two SCRs) connected in parallel is shown in the figure below. In place of two thyristors a single Triac can be used to implement a full wave ac controller, if a suitable Triac is available for the desired RMS load current and the RMS output voltage ratings.

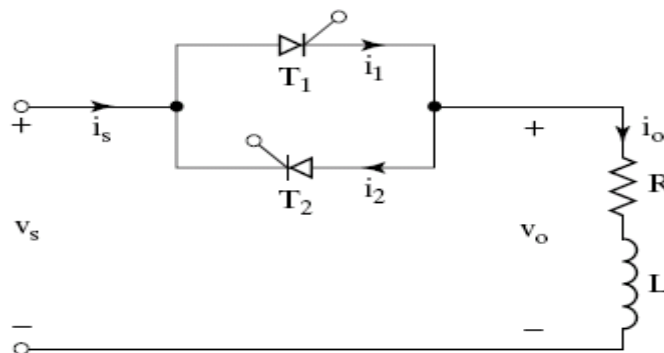

Fig 6.11: Single phase full wave ac voltage controller with RL load

The thyristor T_1 is forward biased during the positive half cycle of input supply. Let us assume that T_1 is triggered at $\omega t = \alpha$, by applying a suitable gate trigger pulse to T_1 during the positive half cycle of input supply. The output voltage across the load follows the input supply voltage when T_1 is ON. The load current i_o flows through the thyristor T_1 and through the load in the downward direction. This load current pulse flowing through T_1 can be considered as the positive current pulse. Due to the inductance in the load, the load current i_o flowing through T_1 would not fall to zero at $\omega t = \pi$, when the input supply voltage starts to become negative.

The thyristor T_1 will continue to conduct the load current until all the inductive energy stored in the load inductor L is completely utilized and the load current through T_1 falls to zero at $\omega t = \beta$, where β is referred to as the Extinction angle, (the value of ωt) at which the

load current falls to zero. The extinction angle β is measured from the point of the beginning of the positive half cycle of input supply to the point where the load current falls to zero.

The thyristor T_1 conducts from $\omega t = \alpha$ to β . The conduction angle of T_1 is $\delta = (\beta - \alpha)$, which depends on the delay angle α and the load impedance angle ϕ . The waveforms of the input supply voltage, the gate trigger pulses of T_1 and T_2 , the thyristor current, the load current and the load voltage waveforms appear as shown in the figure below.

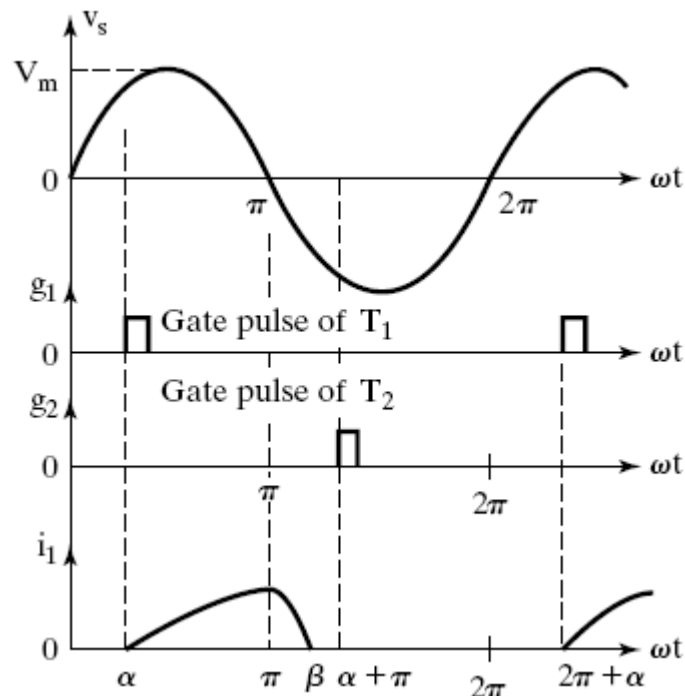

Fig 6.12: Input supply voltage & Thyristor current waveforms

β is the extinction angle which depends upon the load inductance value.

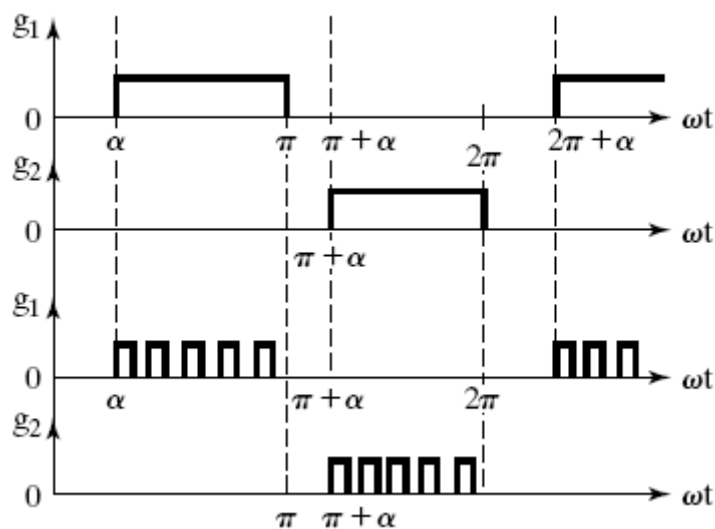

Fig 6.13: Gating Signals

Waveforms of single phase full wave ac voltage controller with RL load for $\alpha > \phi$. Discontinuous load current operation occurs for $\alpha > \phi$ and $\beta < (\pi + \alpha)$; i.e., $(\beta - \alpha) < \pi$, conduction angle $< \pi$.

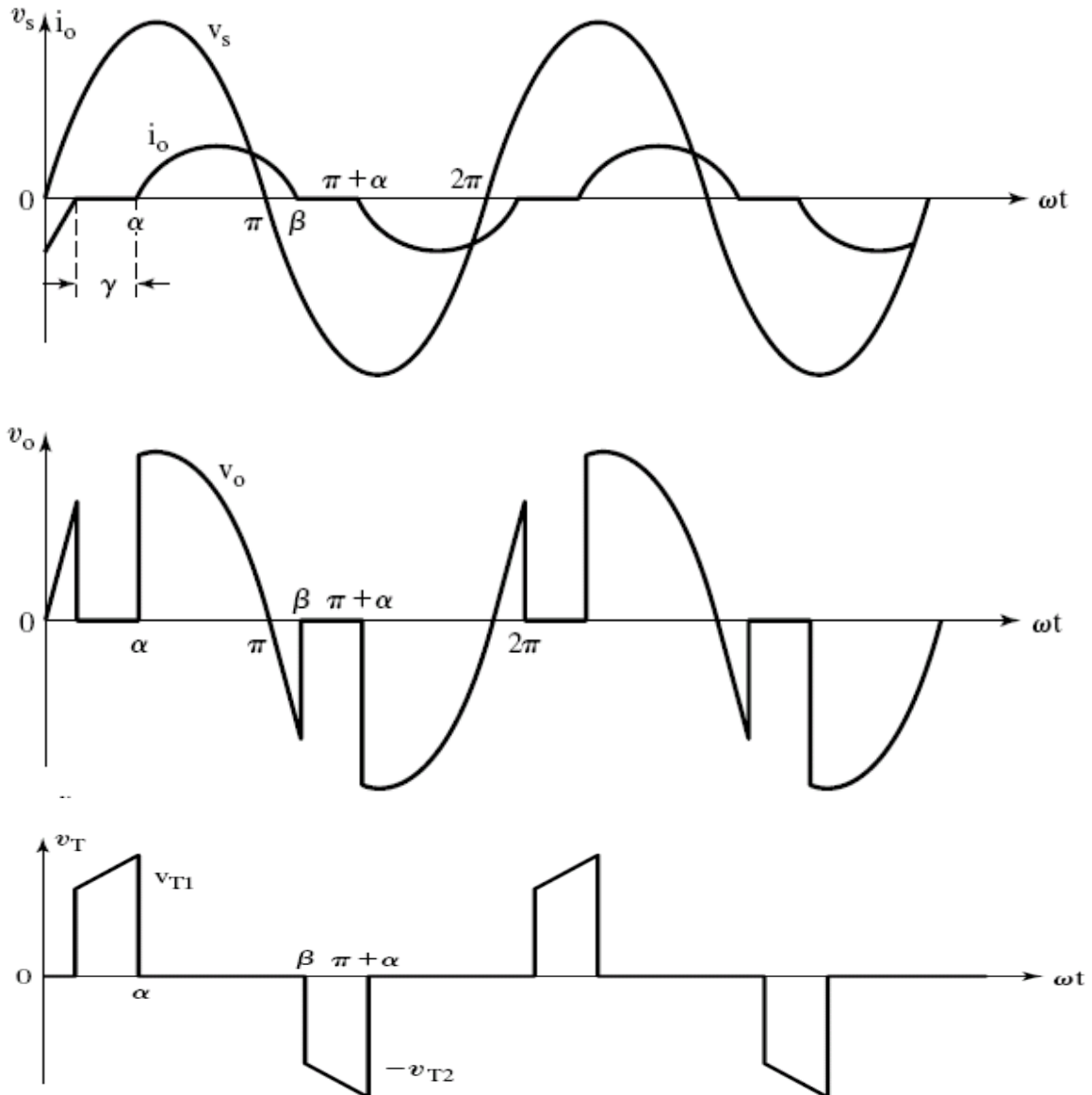

Fig 6.14: Waveforms of Input supply voltage, Load Current, Load Voltage and Thyristor Voltage across T_1

Note

- The RMS value of the output voltage and the load current may be varied by varying the trigger angle α .
- This circuit, AC RMS voltage controller can be used to regulate the RMS voltage across the terminals of an ac motor (induction motor). It can be used to control the temperature of a furnace by varying the RMS output voltage.
- For very large load inductance 'L' the SCR may fail to commute, after it is triggered and the load voltage will be a full sine wave (similar to the applied input supply)

voltage and the output control will be lost) as long as the gating signals are applied to the thyristors T_1 and T_2 . The load current waveform will appear as a full continuous sine wave and the load current waveform lags behind the output sine wave by the load power factor angle ϕ .

(i) To Derive an Expression for the Output (Inductive Load) Current, During $\omega t = \alpha$ to β When Thyristor T_1 Conducts

Considering sinusoidal input supply voltage we can write the expression for the supply voltage as

$$v_s = V_m \sin \omega t = \text{instantaneous value of the input supply voltage.}$$

Let us assume that the thyristor T_1 is triggered by applying the gating signal to T_1 at $\omega t = \alpha$. The load current which flows through the thyristor T_1 during $\omega t = \alpha$ to β can be found from the equation

$$L \left(\frac{di_o}{dt} \right) + Ri_o = V_m \sin \omega t ;$$

The solution of the above differential equation gives the general expression for the output load current which is of the form

$$i_o = \frac{V_m}{Z} \sin(\omega t - \phi) + A_1 e^{\frac{-t}{\tau}} ;$$

Where $V_m = \sqrt{2}V_s = \text{maximum or peak value of input supply voltage.}$

$$Z = \sqrt{R^2 + (\omega L)^2} = \text{Load impedance.}$$

$$\phi = \tan^{-1} \left(\frac{\omega L}{R} \right) = \text{Load impedance angle (power factor angle of load).}$$

$$\tau = \frac{L}{R} = \text{Load circuit time constant.}$$

Therefore the general expression for the output load current is given by the equation

$$i_o = \frac{V_m}{Z} \sin(\omega t - \phi) + A_1 e^{\frac{-R}{L} t} ;$$

The value of the constant A_1 can be determined from the initial condition. i.e. initial value of load current $i_o = 0$, at $\omega t = \alpha$. Hence from the equation for i_o equating i_o to zero and substituting $\omega t = \alpha$, we get

$$i_o = 0 = \frac{V_m}{Z} \sin(\alpha - \phi) + A_1 e^{\frac{-R}{L}t}$$

Therefore $A_1 e^{\frac{-R}{L}t} = \frac{-V_m}{Z} \sin(\alpha - \phi)$

$$A_1 = \frac{1}{e^{\frac{-R}{L}t}} \left[\frac{-V_m}{Z} \sin(\alpha - \phi) \right]$$

$$A_1 = e^{\frac{+R}{L}t} \left[\frac{-V_m}{Z} \sin(\alpha - \phi) \right]$$

$$A_1 = e^{\frac{R(\omega t)}{\omega L}} \left[\frac{-V_m}{Z} \sin(\alpha - \phi) \right]$$

By substituting $\omega t = \alpha$, we get the value of constant A_1 as

$$A_1 = e^{\frac{R(\alpha)}{\omega L}} \left[\frac{-V_m}{Z} \sin(\alpha - \phi) \right]$$

Substituting the value of constant A_1 from the above equation into the expression for i_o , we obtain

$$i_o = \frac{V_m}{Z} \sin(\omega t - \phi) + e^{\frac{-R}{L}t} e^{\frac{R(\alpha)}{\omega L}} \left[\frac{-V_m}{Z} \sin(\alpha - \phi) \right] ;$$

$$i_o = \frac{V_m}{Z} \sin(\omega t - \phi) + e^{\frac{-R(\omega t)}{\omega L}} e^{\frac{R(\alpha)}{\omega L}} \left[\frac{-V_m}{Z} \sin(\alpha - \phi) \right]$$

$$i_o = \frac{V_m}{Z} \sin(\omega t - \phi) + e^{\frac{-R}{\omega L}(\omega t - \alpha)} \left[\frac{-V_m}{Z} \sin(\alpha - \phi) \right]$$

Therefore we obtain the final expression for the inductive load current of a single phase full wave ac voltage controller with RL load as

$$i_o = \frac{V_m}{Z} \left[\sin(\omega t - \phi) - \sin(\alpha - \phi) e^{\frac{-R}{\omega L}(\omega t - \alpha)} \right] ; \quad \text{Where } \alpha \leq \omega t \leq \beta .$$

The above expression also represents the thyristor current i_{T_1} , during the conduction time interval of thyristor T_1 from $\omega t = \alpha$ to β .

To Calculate Extinction Angle β

The extinction angle β , which is the value of ωt at which the load current i_o falls to zero and T_1 is turned off can be estimated by using the condition that $i_o = 0$, at $\omega t = \beta$

By using the above expression for the output load current, we can write

$$i_o = 0 = \frac{V_m}{Z} \left[\sin(\beta - \phi) - \sin(\alpha - \phi) e^{\frac{-R}{\omega L}(\beta - \alpha)} \right]$$

As $\frac{V_m}{Z} \neq 0$ we can write

$$\left[\sin(\beta - \phi) - \sin(\alpha - \phi) e^{\frac{-R}{\omega L}(\beta - \alpha)} \right] = 0$$

Therefore we obtain the expression

$$\sin(\beta - \phi) = \sin(\alpha - \phi) e^{\frac{-R}{\omega L}(\beta - \alpha)}$$

The extinction angle β can be determined from this transcendental equation by using the iterative method of solution (trial and error method). After β is calculated, we can determine the thyristor conduction angle $\delta = (\beta - \alpha)$.

β is the extinction angle which depends upon the load inductance value. Conduction angle δ increases as α is decreased for a known value of β .

For $\delta < \pi$ radians, i.e., for $(\beta - \alpha) < \pi$ radians, for $(\pi + \alpha) > \beta$ the load current waveform appears as a discontinuous current waveform as shown in the figure. The output load current remains at zero during $\omega t = \beta$ to $(\pi + \alpha)$. This is referred to as discontinuous load current operation which occurs for $\beta < (\pi + \alpha)$.

When the trigger angle α is decreased and made equal to the load impedance angle ϕ i.e., when $\alpha = \phi$ we obtain from the expression for $\sin(\beta - \phi)$,

$$\sin(\beta - \phi) = 0 ; \quad \text{Therefore } (\beta - \phi) = \pi \text{ radians.}$$

Extinction angle $\beta = (\pi + \phi) = (\pi + \alpha)$; for the case when $\alpha = \phi$

Conduction angle $\delta = (\beta - \alpha) = \pi$ radians = 180° ; for the case when $\alpha = \phi$

Each thyristor conducts for 180° (π radians) . T_1 conducts from $\omega t = \phi$ to $(\pi + \phi)$ and provides a positive load current. T_2 conducts from $(\pi + \phi)$ to $(2\pi + \phi)$ and provides a negative load current. Hence we obtain a continuous load current and the output voltage waveform appears as a continuous sine wave identical to the input supply voltage waveform for trigger angle $\alpha \leq \phi$ and the control on the output is lost.

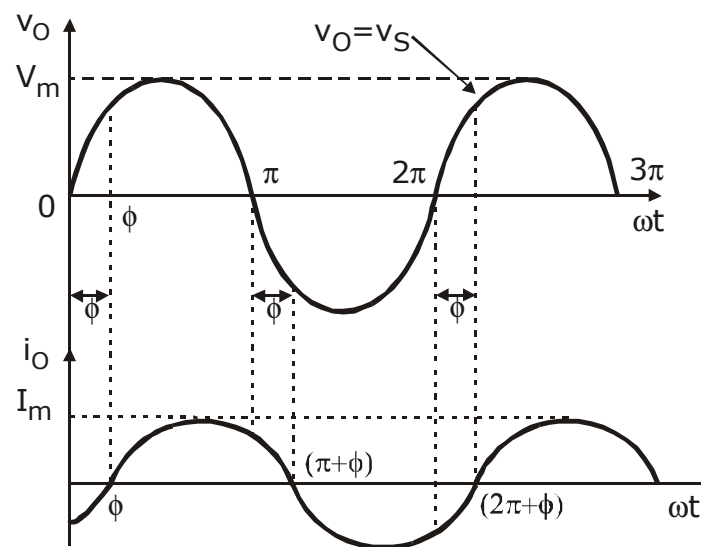

Fig 6.15: Output Voltage And Output Current Waveforms For A Single Phase Full Wave Ac Voltage Controller With RL Load For $\alpha \leq \phi$

Thus we observe that for trigger angle $\alpha \leq \phi$, the load current tends to flow continuously and we have continuous load current operation, without any break in the load current waveform and we obtain output voltage waveform which is a continuous sinusoidal waveform identical to the input supply voltage waveform. We lose the control on the output voltage for $\alpha \leq \phi$ as the output voltage becomes equal to the input supply voltage and thus we obtain

$$V_{O(RMS)} = \frac{V_m}{\sqrt{2}} = V_s ; \text{ for } \alpha \leq \phi$$

Hence,

$$\text{RMS output voltage} = \text{RMS input supply voltage for } \alpha \leq \phi$$

(ii) To Derive an Expression For rms Output Voltage $V_{O(RMS)}$ of a Single Phase Full-Wave Ac Voltage Controller with RL Load.

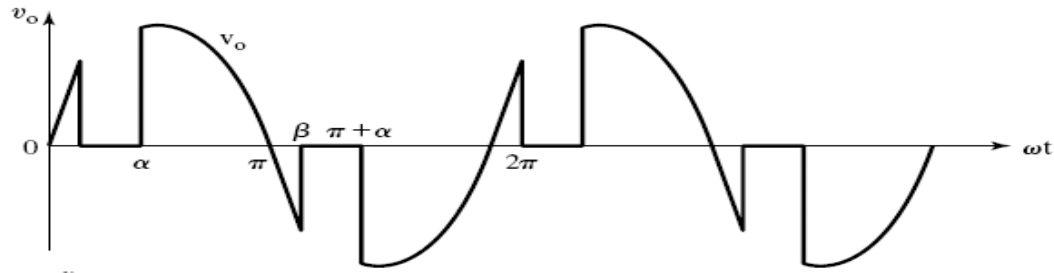

When $\alpha > \phi$, the load current and load voltage waveforms become discontinuous as shown in the figure above.

$$V_{O(RMS)} = \left[\frac{1}{\pi} \int_{\alpha}^{\beta} V_m^2 \sin^2 \omega t \cdot d(\omega t) \right]^{\frac{1}{2}}$$

Output $v_o = V_m \sin \omega t$, for $\omega t = \alpha$ to β , when T_1 is ON.

$$V_{O(RMS)} = \left[\frac{V_m^2}{\pi} \int_{\alpha}^{\beta} \frac{(1 - \cos 2\omega t)}{2} d(\omega t) \right]^{\frac{1}{2}}$$

$$V_{O(RMS)} = \left[\frac{V_m^2}{2\pi} \left\{ \int_{\alpha}^{\beta} d(\omega t) - \int_{\alpha}^{\beta} \cos 2\omega t \cdot d(\omega t) \right\} \right]^{\frac{1}{2}}$$

$$V_{O(RMS)} = \left[\frac{V_m^2}{2\pi} \left\{ (\omega t) \Big|_{\alpha}^{\beta} - \left(\frac{\sin 2\omega t}{2} \right) \Big|_{\alpha}^{\beta} \right\} \right]^{\frac{1}{2}}$$

$$V_{O(RMS)} = \left[\frac{V_m^2}{2\pi} \left\{ (\beta - \alpha) - \frac{\sin 2\beta}{2} + \frac{\sin 2\alpha}{2} \right\} \right]^{\frac{1}{2}}$$

$$V_{O(RMS)} = V_m \left[\frac{1}{2\pi} \left\{ (\beta - \alpha) + \frac{\sin 2\alpha}{2} - \frac{\sin 2\beta}{2} \right\} \right]^{\frac{1}{2}}$$

$$V_{O(RMS)} = \frac{V_m}{\sqrt{2}} \left[\frac{1}{\pi} \left\{ (\beta - \alpha) + \frac{\sin 2\alpha}{2} - \frac{\sin 2\beta}{2} \right\} \right]^{\frac{1}{2}}$$

The RMS output voltage across the load can be varied by changing the trigger angle α .

For a purely resistive load $L = 0$, therefore load power factor angle $\phi = 0$.

$$\phi = \tan^{-1}\left(\frac{\omega L}{R}\right) = 0 ;$$

Extinction angle $\beta = \pi$ radians = 180°

Performance Parameters of A Single Phase Full Wave Ac Voltage Controller with Resistive Load

- **RMS Output Voltage** $V_{O(RMS)} = \frac{V_m}{\sqrt{2}} \sqrt{\frac{1}{\pi} \left[(\pi - \alpha) + \frac{\sin 2\alpha}{2} \right]}$; $\frac{V_m}{\sqrt{2}} = V_s =$ RMS input supply voltage.

- $I_{O(RMS)} = \frac{V_{O(RMS)}}{R_L} =$ RMS value of load current.

- $I_s = I_{O(RMS)} =$ RMS value of input supply current.

- **Output load power**

$$P_o = I_{O(RMS)}^2 \times R_L$$

- **Input Power Factor**

$$PF = \frac{P_o}{V_s \times I_s} = \frac{I_{O(RMS)}^2 \times R_L}{V_s \times I_{O(RMS)}} = \frac{I_{O(RMS)} \times R_L}{V_s}$$

$$PF = \frac{V_{O(RMS)}}{V_s} = \sqrt{\frac{1}{\pi} \left[(\pi - \alpha) + \frac{\sin 2\alpha}{2} \right]}$$

- **Average Thyristor Current,**

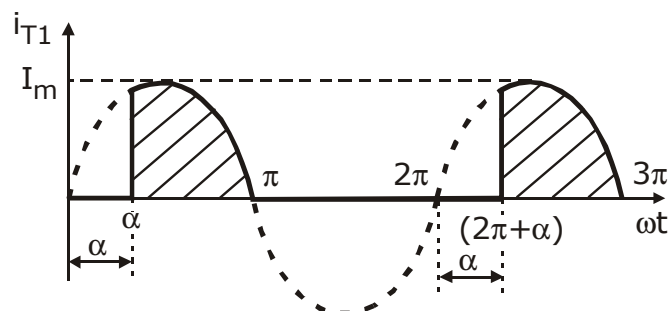

Fig6.16: Thyristor Current Waveform

$$I_{T(Avg)} = \frac{1}{2\pi} \int_{\alpha}^{\pi} i_T d(\omega t) = \frac{1}{2\pi} \int_{\alpha}^{\pi} I_m \sin \omega t. d(\omega t)$$

$$I_{T(Avg)} = \frac{I_m}{2\pi} \int_{\alpha}^{\pi} \sin \omega t \cdot d(\omega t) = \frac{I_m}{2\pi} \left[-\cos \omega t \right]_{\alpha}^{\pi}$$

$$I_{T(Avg)} = \frac{I_m}{2\pi} [-\cos \pi + \cos \alpha] = \frac{I_m}{2\pi} [1 + \cos \alpha]$$

- **Maximum Average Thyristor Current, for $\alpha = 0$,**

$$I_{T(Avg)} = \frac{I_m}{\pi}$$

- **RMS Thyristor Current**

$$I_{T(RMS)} = \sqrt{\frac{1}{2\pi} \left[\int_{\alpha}^{\pi} I_m^2 \sin^2 \omega t \cdot d(\omega t) \right]}$$

$$I_{T(RMS)} = \frac{I_m}{\sqrt{2}} \sqrt{\frac{1}{2\pi} \left[(\pi - \alpha) + \frac{\sin 2\alpha}{2} \right]}$$

- **Maximum RMS Thyristor Current, for $\alpha = 0$,**

$$I_{T(RMS)} = \frac{I_m}{2}$$

In the case of a single phase full wave ac voltage controller circuit using a Triac with resistive load, the average thyristor current $I_{T(Avg)} = 0$. Because the Triac conducts in both the half cycles and the thyristor current is alternating and we obtain a symmetrical thyristor current waveform which gives an average value of zero on integration.

Performance Parameters of A Single Phase Full Wave Ac Voltage Controller with R-L Load

The Expression for the Output (Load) Current

The expression for the output (load) current which flows through the thyristor, during $\omega t = \alpha$ to β is given by

$$i_o = i_{T_1} = \frac{V_m}{Z} \left[\sin(\omega t - \phi) - \sin(\alpha - \phi) e^{\frac{-R}{\omega L}(\omega t - \alpha)} \right] ; \quad \text{for } \alpha \leq \omega t \leq \beta$$

Where,

$$V_m = \sqrt{2}V_s = \text{Maximum or peak value of input ac supply voltage.}$$

$$Z = \sqrt{R^2 + (\omega L)^2} = \text{Load impedance.}$$

$$\phi = \tan^{-1} \left(\frac{\omega L}{R} \right) = \text{Load impedance angle (load power factor angle).}$$

$$\alpha = \text{Thyristor trigger angle} = \text{Delay angle.}$$

β = Extinction angle of thyristor, (value of ωt) at which the thyristor (load) current falls to zero.

β is calculated by solving the equation

$$\sin(\beta - \phi) = \sin(\alpha - \phi) e^{\frac{-R}{\omega L}(\beta - \alpha)}$$

Thyristor Conduction Angle $\delta = (\beta - \alpha)$

Maximum thyristor conduction angle $\delta = (\beta - \alpha) = \pi$ radians = 180° for $\alpha \leq \phi$.

RMS Output Voltage

$$V_{O(RMS)} = \frac{V_m}{\sqrt{2}} \sqrt{\frac{1}{\pi} \left[(\beta - \alpha) + \frac{\sin 2\alpha}{2} - \frac{\sin 2\beta}{2} \right]}$$

The Average Thyristor Current

$$I_{T(Avg)} = \frac{1}{2\pi} \left[\int_{\alpha}^{\beta} i_{T_1} d(\omega t) \right]$$

$$I_{T(Avg)} = \frac{1}{2\pi} \left[\int_{\alpha}^{\beta} \frac{V_m}{Z} \left[\sin(\omega t - \phi) - \sin(\alpha - \phi) e^{\frac{-R}{\omega L}(\omega t - \alpha)} \right] d(\omega t) \right]$$

$$I_{T(Avg)} = \frac{V_m}{2\pi Z} \left[\int_{\alpha}^{\beta} \sin(\omega t - \phi) d(\omega t) - \int_{\alpha}^{\beta} \sin(\alpha - \phi) e^{\frac{-R}{\omega L}(\omega t - \alpha)} d(\omega t) \right]$$

Maximum value of $I_{T(Avg)}$ occur at $\alpha = 0$. The thyristors should be rated for maximum $I_{T(Avg)} = \left(\frac{I_m}{\pi} \right)$, where $I_m = \frac{V_m}{Z}$.

RMS Thyristor Current $I_{T(RMS)}$

$$I_{T(RMS)} = \sqrt{\frac{1}{2\pi} \int_{\alpha}^{\beta} i_{T_1}^2 d(\omega t)}$$

Maximum value of $I_{T(RMS)}$ occurs at $\alpha = 0$. Thyristors should be rated for maximum

$$I_{T(RMS)} = \left(\frac{I_m}{2} \right)$$

When a Triac is used in a single phase full wave ac voltage controller with RL type of load, then $I_{T(Avg)} = 0$ and maximum $I_{T(RMS)} = \frac{I_m}{\sqrt{2}}$

PROBLEMS

1. A single phase full wave ac voltage controller supplies an RL load. The input supply voltage is 230V, RMS at 50Hz. The load has $L = 10\text{mH}$, $R = 10\Omega$, the delay angle of thyristors T_1 and T_2 are equal, where $\alpha_1 = \alpha_2 = \frac{\pi}{3}$. Determine

- Conduction angle of the thyristor T_1 .
- RMS output voltage.
- The input power factor.

Comment on the type of operation.

Given

$$V_s = 230V, \quad f = 50\text{Hz}, \quad L = 10\text{mH}, \quad R = 10\Omega, \quad \alpha = 60^\circ, \quad \alpha = \alpha_1 = \alpha_2 = \frac{\pi}{3}$$

radians, .

$$V_m = \sqrt{2}V_s = \sqrt{2} \times 230 = 325.2691193 \text{ V}$$

$$Z = \text{Load Impedance} = \sqrt{R^2 + (\omega L)^2} = \sqrt{(10)^2 + (\omega L)^2}$$

$$\omega L = (2\pi fL) = (2\pi \times 50 \times 10 \times 10^{-3}) = \pi = 3.14159\Omega$$

$$Z = \sqrt{(10)^2 + (3.14159)^2} = \sqrt{109.8696} = 10.4818\Omega$$

$$I_m = \frac{V_m}{Z} = \frac{\sqrt{2} \times 230}{10.4818} = 31.03179 \text{ A}$$

$$\text{Load Impedance Angle } \phi = \tan^{-1}\left(\frac{\omega L}{R}\right)$$

$$\phi = \tan^{-1}\left(\frac{\pi}{10}\right) = \tan^{-1}(0.314159) = 17.44059^\circ$$

Trigger Angle $\alpha > \phi$. Hence the type of operation will be discontinuous load current operation, we get

$$\beta < (\pi + \alpha)$$

$$\beta < (180 + 60) ; \beta < 240^\circ$$

Therefore the range of β is from 180 degrees to 240 degrees. $(180^\circ < \beta < 240^\circ)$

Extinction Angle β is calculated by using the equation

$$\sin(\beta - \phi) = \sin(\alpha - \phi) e^{\frac{-R}{\omega L}(\beta - \alpha)}$$

In the exponential term the value of α and β should be substituted in radians. Hence

$$\sin(\beta - \phi) = \sin(\alpha - \phi) e^{\frac{-R}{\omega L}(\beta_{Rad} - \alpha_{Rad})} ; \alpha_{Rad} = \left(\frac{\pi}{3}\right)$$

$$(\alpha - \phi) = (60 - 17.44059) = 42.5594^\circ$$

$$\sin(\beta - 17.44)^\circ = \sin(42.5594^\circ) e^{\frac{-10}{\pi}(\beta - \alpha)}$$

$$\sin(\beta - 17.44)^\circ = 0.676354 e^{-3.183(\beta - \alpha)}$$

$$180^\circ \rightarrow \pi \text{ radians, } \beta_{Rad} = \frac{\beta^\circ \times \pi}{180^\circ}$$

Assuming $\beta = 190^\circ$;

$$\beta_{Rad} = \frac{\beta^\circ \times \pi}{180^\circ} = \frac{190^\circ \times \pi}{180} = 3.3161$$

$$\text{L.H.S: } \sin(190 - 17.44)^\circ = \sin(172.56) = 0.129487$$

$$\text{R.H.S: } 0.676354 \times e^{-3.183\left(3.3161 - \frac{\pi}{3}\right)} = 4.94 \times 10^{-4}$$

Assuming $\beta = 183^\circ$;

$$\beta_{Rad} = \frac{\beta^\circ \times \pi}{180^\circ} = \frac{183^\circ \times \pi}{180} = 3.19395$$

$$(\beta - \alpha) = \left(3.19395 - \frac{\pi}{3}\right) = 2.14675$$

$$\text{L.H.S: } \sin(\beta - \phi) = \sin(183 - 17.44) = \sin 165.56^\circ = 0.24936$$

$$\text{R.H.S: } 0.676354 e^{-3.183(2.14675)} = 7.2876 \times 10^{-4}$$

Assuming $\beta \approx 180^\circ$

$$\beta_{Rad} = \frac{\beta^\circ \times \pi}{180^\circ} = \frac{180^\circ \times \pi}{180} = \pi$$

$$(\beta - \alpha) = \left(\pi - \frac{\pi}{3}\right) = \left(\frac{2\pi}{3}\right)$$

$$\text{L.H.S: } \sin(\beta - \phi) = \sin(180 - 17.44) = 0.2997$$

$$\text{R.H.S: } 0.676354e^{-3.183\left(\pi-\frac{\pi}{3}\right)} = 8.6092 \times 10^{-4}$$

Assuming $\beta = 196^\circ$

$$\beta_{Rad} = \frac{\beta^0 \times \pi}{180^0} = \frac{196^0 \times \pi}{180} = 3.420845$$

$$\text{L.H.S: } \sin(\beta - \phi) = \sin(196 - 17.44) = 0.02513$$

$$\text{R.H.S: } 0.676354e^{-3.183\left(3.420845-\frac{\pi}{3}\right)} = 3.5394 \times 10^{-4}$$

Assuming $\beta = 197^\circ$

$$\beta_{Rad} = \frac{\beta^0 \times \pi}{180^0} = \frac{197^0 \times \pi}{180} = 3.43829$$

$$\text{L.H.S: } \sin(\beta - \phi) = \sin(197 - 17.44) = 7.69 = 7.67937 \times 10^{-3}$$

$$\text{R.H.S: } 0.676354e^{-3.183\left(3.43829-\frac{\pi}{3}\right)} = 4.950386476 \times 10^{-4}$$

Assuming $\beta = 197.42^\circ$

$$\beta_{Rad} = \frac{\beta^0 \times \pi}{180^0} = \frac{197.42 \times \pi}{180} = 3.4456$$

$$\text{L.H.S: } \sin(\beta - \phi) = \sin(197.42 - 17.44) = 3.4906 \times 10^{-4}$$

$$\text{R.H.S: } 0.676354e^{-3.183\left(3.4456-\frac{\pi}{3}\right)} = 3.2709 \times 10^{-4}$$

$$\text{Conduction Angle } \delta = (\beta - \alpha) = (197.42^\circ - 60^\circ) = 137.42^\circ$$

RMS Output Voltage

$$V_{O(RMS)} = V_s \sqrt{\frac{1}{\pi} \left[(\beta - \alpha) + \frac{\sin 2\alpha}{2} - \frac{\sin 2\beta}{2} \right]}$$

$$V_{O(RMS)} = 230 \sqrt{\frac{1}{\pi} \left[\left(3.4456 - \frac{\pi}{3} \right) + \frac{\sin 2(60^\circ)}{2} - \frac{\sin 2(197.42^\circ)}{2} \right]}$$

$$V_{O(RMS)} = 230 \sqrt{\frac{1}{\pi} [(2.39843) + 0.4330 - 0.285640]}$$

$$V_{O(RMS)} = 230 \times 0.9 = 207.0445 \text{ V}$$

Input Power Factor

$$PF = \frac{P_o}{V_s \times I_s}$$

$$I_{O(RMS)} = \frac{V_{O(RMS)}}{Z} = \frac{207.0445}{10.4818} = 19.7527 \text{ A}$$

$$P_o = I_{O(RMS)}^2 \times R_L = (19.7527)^2 \times 10 = 3901.716 \text{ W}$$

$$V_s = 230\text{V}, \quad I_s = I_{O(RMS)} = 19.7527$$

$$PF = \frac{P_o}{V_s \times I_s} = \frac{3901.716}{230 \times 19.7527} = 0.8588$$

2. A single phase full wave controller has an input voltage of 120 V (RMS) and a load resistance of 6 ohm. The firing angle of thyristor is $\pi/2$. Find

- d. RMS output voltage
- e. Power output
- f. Input power factor
- g. Average and RMS thyristor current.

Solution

$$\alpha = \frac{\pi}{2} = 90^\circ, \quad V_s = 120 \text{ V}, \quad R = 6\Omega$$

RMS Value of Output Voltage

$$V_o = V_s \left[\frac{1}{\pi} \left(\pi - \alpha + \frac{\sin 2\alpha}{2} \right) \right]^{\frac{1}{2}}$$

$$V_o = 120 \left[\frac{1}{\pi} \left(\pi - \frac{\pi}{2} + \frac{\sin 180}{2} \right) \right]^{\frac{1}{2}}$$

$$V_o = 84.85 \text{ Volts}$$

RMS Output Current

$$I_o = \frac{V_o}{R} = \frac{84.85}{6} = 14.14 \text{ A}$$

Load Power

$$P_o = I_o^2 \times R$$

$$P_o = (14.14)^2 \times 6 = 1200 \text{ watts}$$

Input Current is same as Load Current

Therefore $I_s = I_o = 14.14$ Amps

Input Supply Volt-Amp = $V_s I_s = 120 \times 14.14 = 1696.8$ VA

Therefore

$$\text{Input Power Factor} = \frac{\text{Load Power}}{\text{Input Volt-Amp}} = \frac{1200}{1696.8} = 0.707 (\text{lag})$$

Each Thyristor Conducts only for half a cycle

Average thyristor current $I_{T(Avg)}$

$$\begin{aligned} I_{T(Avg)} &= \frac{1}{2\pi R} \int_{\alpha}^{\pi} V_m \sin \omega t \cdot d(\omega t) \\ &= \frac{V_m}{2\pi R} (1 + \cos \alpha) ; \quad V_m = \sqrt{2} V_s \\ &= \frac{\sqrt{2} \times 120}{2\pi \times 6} [1 + \cos 90] = 4.5 \text{ A} \end{aligned}$$

RMS thyristor current $I_{T(RMS)}$

$$\begin{aligned} I_{T(RMS)} &= \sqrt{\frac{1}{2\pi} \int_{\alpha}^{\pi} \frac{V_m^2 \sin^2 \omega t}{R^2} d(\omega t)} \\ &= \sqrt{\frac{V_m^2}{2\pi R^2} \int_{\alpha}^{\pi} \frac{(1 - \cos 2\omega t)}{2} d(\omega t)} \\ &= \frac{V_m}{2R} \left[\frac{1}{\pi} \left(\pi - \alpha + \frac{\sin 2\alpha}{2} \right) \right]^{\frac{1}{2}} \\ &= \frac{\sqrt{2} V_s}{2R} \left[\frac{1}{\pi} \left(\pi - \alpha + \frac{\sin 2\alpha}{2} \right) \right]^{\frac{1}{2}} \\ &= \frac{\sqrt{2} \times 120}{2 \times 6} \left[\frac{1}{\pi} \left(\pi - \frac{\pi}{2} + \frac{\sin 180}{2} \right) \right]^{\frac{1}{2}} = 10 \text{ Amps} \end{aligned}$$

3. A single phase half wave ac regulator using one SCR in anti-parallel with a diode feeds 1 kW, 230 V heater. Find load power for a firing angle of 45° .

Solution

$$\alpha = 45^\circ = \frac{\pi}{4}, \quad V_s = 230 \text{ V} ; P_o = 1\text{KW} = 1000\text{W}$$

At standard rms supply voltage of 230V, the heater dissipates 1KW of output power

Therefore

$$P_o = V_o \times I_o = \frac{V_o \times V_o}{R} = \frac{V_o^2}{R}$$

Resistance of heater

$$R = \frac{V_o^2}{P_o} = \frac{(230)^2}{1000} = 52.9\Omega$$

RMS value of output voltage

$$V_o = V_s \left[\frac{1}{2\pi} \left(2\pi - \alpha + \frac{\sin 2\alpha}{2} \right) \right]^{\frac{1}{2}} \quad ; \text{ for firing angle } \alpha = 45^\circ$$

$$V_o = 230 \left[\frac{1}{2\pi} \left(2\pi - \frac{\pi}{4} + \frac{\sin 90}{2} \right) \right]^{\frac{1}{2}} = 224.7157 \text{ Volts}$$

RMS value of output current

$$I_o = \frac{V_o}{R} = \frac{224.9}{52.9} = 4.2479 \text{ Amps}$$

Load Power

$$P_o = I_o^2 \times R = (4.25)^2 \times 52.9 = 954.56 \text{ Watts}$$

4. Find the RMS and average current flowing through the heater shown in figure. The delay angle of both the SCRs is 45° .

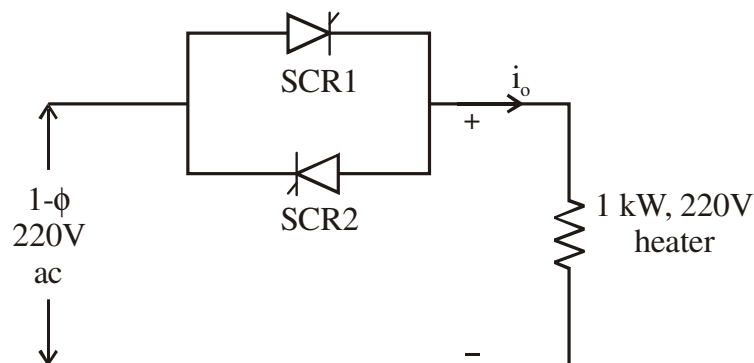
**Solution**

$$\alpha = 45^\circ = \frac{\pi}{4}, \quad V_s = 220 \text{ V}$$

Resistance of heater

$$R = \frac{V^2}{R} = \frac{(220)^2}{1000} = 48.4\Omega$$

Resistance value of output voltage

$$V_o = V_s \sqrt{\left[\frac{1}{\pi} \left(\pi - \alpha + \frac{\sin 2\alpha}{2} \right) \right]}$$

$$V_o = 220 \sqrt{\left[\frac{1}{\pi} \left(\pi - \frac{\pi}{4} + \frac{\sin 90}{2} \right) \right]}$$

$$V_o = 220 \sqrt{\left[\frac{1}{\pi} \left(\pi - \frac{\pi}{4} + \frac{1}{2} \right) \right]} = 209.769 \text{ Volts}$$

$$\text{RMS current flowing through heater} = \frac{V_o}{R} = \frac{209.769}{48.4} = 4.334 \text{ Amps}$$

$$\text{Average current flowing through the heater} \quad I_{Avg} = 0$$

5. A single phase voltage controller is employed for controlling the power flow from 220 V, 50 Hz source into a load circuit consisting of $R = 4 \Omega$ and $L = 6 \text{ mH}$. Calculate the following

- Control range of firing angle
- Maximum value of RMS load current
- Maximum power and power factor
- Maximum value of average and RMS thyristor current.

Solution

For control of output power, minimum angle of firing angle α is equal to the load impedance angle θ

$$\alpha = \theta, \text{ load angle}$$

$$\theta = \tan^{-1} \left(\frac{\omega L}{R} \right) = \tan^{-1} \left(\frac{6}{4} \right) = 56.3^\circ$$

Maximum possible value of α is 180°

Therefore control range of firing angle is $56.3^\circ < \alpha < 180^\circ$

Maximum value of RMS load current occurs when $\alpha = \theta = 56.3^\circ$. At this value of α the Maximum value of RMS load current

$$I_o = \frac{V_s}{Z} = \frac{220}{\sqrt{4^2 + 6^2}} = 30.5085 \text{ Amps}$$

Maximum Power $P_o = I_o^2 R = (30.5085)^2 \times 4 = 3723.077 \text{ W}$

Input Volt-Amp $= V_s I_o = 220 \times 30.5085 = 6711.87 \text{ W}$

$$\text{Power Factor} = \frac{P_o}{\text{Input VA}} = \frac{3723.077}{6711.87} = 0.5547$$

Average thyristor current will be maximum when $\alpha = \theta$ and conduction angle $\gamma = 180^\circ$.

Therefore maximum value of average thyristor current

$$I_{T(\text{Avg})} = \frac{1}{2\pi} \int_{\alpha}^{\pi+\alpha} \frac{V_m}{Z} \sin(\omega t - \theta) d(\omega t)$$

Note: $i_o = i_{T_1} = \frac{V_m}{Z} \left[\sin(\omega t - \theta) - \sin(\alpha - \theta) e^{\frac{-R}{\omega L}(\omega t - \alpha)} \right]$

At $\alpha = 0$,

$$i_{T_1} = i_o = \frac{V_m}{Z} \sin(\omega t - \theta)$$

$$I_{T(\text{Avg})} = \frac{V_m}{2\pi Z} \left[-\cos(\omega t - \theta) \right]_{\alpha}^{\pi+\alpha}$$

$$I_{T(\text{Avg})} = \frac{V_m}{2\pi Z} \left[-\cos(\pi + \alpha - \theta) + \cos(\alpha - \theta) \right]$$

But $\alpha = \theta$,

$$I_{T(\text{Avg})} = \frac{V_m}{2\pi Z} \left[-\cos(\pi) + \cos(0) \right] = \frac{V_m}{2\pi Z} [2] = \frac{V_m}{\pi Z}$$

$$\therefore I_{T(\text{Avg})} = \frac{V_m}{\pi Z} = \frac{\sqrt{2} \times 220}{\pi \sqrt{4^2 + 6^2}} = 13.7336 \text{ Amps}$$

Similarly, maximum RMS value occurs when $\alpha = 0$ and $\gamma = \pi$.

Therefore maximum value of RMS thyristor current

$$I_{TM} = \sqrt{\frac{1}{2\pi} \int_{\alpha}^{\pi+\alpha} \left\{ \frac{V_m}{Z} \sin(\omega t - \theta) \right\}^2 d(\omega t)}$$

$$I_{TM} = \sqrt{\frac{V_m^2}{2\pi Z^2} \int_{\alpha}^{\pi+\alpha} \left[\frac{1 - \cos(2\omega t - 2\theta)}{2} \right] d(\omega t)}$$

$$I_{TM} = \sqrt{\frac{V_m^2}{4\pi Z^2} \left[\omega t - \frac{\sin(2\omega t - 2\theta)}{2} \right]_{\alpha}^{\pi+\alpha}}$$

$$I_{TM} = \sqrt{\frac{V_m^2}{4\pi Z^2} [\pi + \alpha - \alpha - 0]}$$

$$I_{TM} = \frac{V_m}{2Z} = \frac{\sqrt{2} \times 220}{2\sqrt{4^2 + 6^2}} = 21.57277 \text{ Amps}$$

Recommended questions:

1. Discuss the operation of a single phase controller supplying a resistive load, and controlled by the on-off method of control. Also highlight the advantages and disadvantages of such a control. Draw the relevant waveforms.
2. What phase angle control is as applied to single phase controllers? Highlight the advantages and disadvantages of such a method of control. Draw all the wave forms.
3. What are the effects of load inductance on the performance of voltage controllers?
4. Explain the meaning of extinction angle as applied to single phase controllers supplying inductive load with the help of waveforms.
5. What are unidirectional controllers? Explain the operation of the same with the help of waveforms and obtain the expression for the RMS value of the output voltage. What are the advantage and disadvantages of unidirectional controllers?
6. What are bi-directional controllers explain the operation of the same with the help of waveforms and obtain the expression for the R<S value of the output voltage. RMS value of thyristor current. What are the advantages of bi-directional controllers?
7. The AC Voltage controller shown below is used for heating a resistive load of 5Ω and the input voltage $V_s = 120 \text{ V (rms)}$. The thyristor switch is on for $n=125$ cycles and is off for $m = 75$ cycles. Determine the RMS output voltage V_o , the input factor and the average and RMS thyristor current.

8.

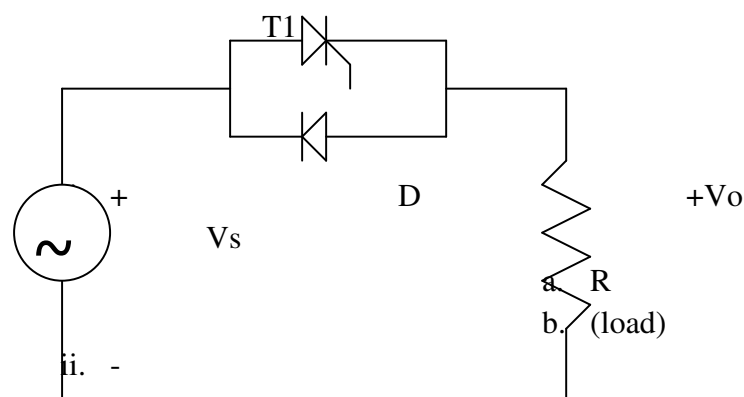

in the problem above $R=4\Omega$, $V_s = 208$ V (rms) if the desired output power is 3 KW, determine the duty cycle 'K' and the input power factor.

9. The single phases half wave controller shown in the figure above has a resistive load of $R=5\Omega$ and the input voltage $V_s=120$ V(rms), 50 Hz. The delay angle of the thyristor is . Determine the RMS voltage, the output V_o input power factor and the average input current. Also derive the expressions for the same.
10. The single phase unidirectional controller in the above problem, has a resistive load of 5Ω and the input voltage $V_s = 208$ V (rms). If the desired output power is 2 KW, calculate the delay angle α of the thyristor and the input power factor.

